

TACO Marine® Grand Slam Mounts

Masthead Anchor Light

INSTALLATION INSTRUCTION GUIDE



WARNING:

This product can expose you to chemicals including Lead, which is known to the State of California to cause cancer, birth defects or other reproductive harm. For more information go to www.P65Warnings.ca.gov.



TACO[®]
MARINE

KIT CONTENTS

1

Grand Slam 900 mount

1

Light assembly

1

32.75" tube

1

Aluminum backing plate

1

Drill template

3

Vinyl tubing spacers

Required*

*not included

- SAFETY GLASSES
- POWER DRILL
- SCREW GUN (OPTIONAL)
- MASKING TAPE
- 1/4" DRILL BIT
- 2-1/2" HOLE SAW
- THREE 1/4-20 FLAT, PHILLIPS HEAD SCREWS*
- THREE 1/4-20 NYLON LOCKING NUTS*
- MARINE-GRADE SEALANT
- PENCIL
- THREE MARINE-GRADE #18 GAUGE WIRE (LENGTH BASED ON APPLICATION)

* Fastener length may be different, depending on the application. For assistance, please contact TACO Technical Support on tacomarine.com.

TACO® Handy Tips

- Prepare for installation by ensuring the mounting surface is clean of any grease and/or dirt.
- Ensure your hardtop is suitably constructed to provide a strong mounting surface area for your Masthead Anchor Light. The GS-900 was designed specifically to prevent climbing on the boat gunnel to raise and lower a Masthead Anchor Light.
- If the top is arched, wedge plates can be used to maintain proper alignment.

GS-900

Thank you for purchasing the TACO Marine 900 Masthead Anchor Light by TACO Marine. Since 1959, we have taken great pride in offering the highest-quality products with excellent customer service. We stand behind our products 100 percent. Please visit our website **tacomarine.com** for more detailed information on a wide variety of products and to register your new accessory for warranty.

Important notes:

- The maximum hardtop thickness allowable is 2”.
- A backing plate is included for extra strength during your installation and is recommended to use when mounting through a hardtop.
- When installing the GS-900, designate the location for the mount at least 9” from the hardtop frame, vertical post or any other object that might hinder the rotation of the crank handle.
- Turning the crank assembly handle will allow the Masthead Anchor Light to adjust to the full up position when rotating it counter-clockwise.
- Turning the handle clockwise will adjust the Masthead Anchor Light to the full down position.
- Ensure the canvas T-top, arch or hardtop is of suitable construction to provide a strong mounting surface area.
- When installing on a hardtop, verify the top is foam or core filled.
- The GS-900 incorporates a folding crank handle that securely locks flush within the rotator base.

-
- The supplied template is only a guide to help align the base for true hole positioning. Make sure nothing is rubbing in the 2-1/2” hole. There should be a small gap all the way around.
 - Always use good quality stainless-steel hardware when mounting the base.
 - The best way to determine proper placement of the mount is to (1) identify the location of all the other components on the top and (2) ensure its location will be good for operating the mount from under the top when cranking the handle while standing on the deck of the boat. Because Masthead Anchor Lights vary in length, the right

- location may vary based on your preferred length of the Masthead Anchor Light.
- Before drilling into the top, ensure the mount position and the light will not interfere with other top-mounted accessories when it is in full up and full down positions.
- The Masthead Anchor Light must be the highest point of the boat when deployed.

INSTALLATION

BASE

Always use high-quality, stainless-steel hardware when mounting the base. Do not attempt to weld the base to any surface.

1. Verify the Masthead Anchor Light does not interfere with other top-mounted accessories.
2. Using the drill template provided, cut out a 2-1/2" diameter center hole on the top.
3. Position the base centered in the 2-1/2" hole.
4. Use the drill template to mark and then drill the three (3) bolt holes with a 1/4" bit. Then insert the vinyl spacers into the bolt holes.
5. Place a bead of marine-grade sealant on the underside edge of the backing plate. This will prevent water intrusion.
6. With the assistance of a helper, position the backing plate around the base from under the top, align the holes in the base with the backing plate and insert the bolts through the base, top and backing plate.
7. Hold the bolts securely with a screwdriver or socket wrench while the nuts are threaded onto the bolts.
8. Tighten the nuts, being careful not to over-tighten and deform the top surface.
9. Clean any excess marine-grade sealant from the surface.
10. Operate unit to full up and down position and check for proper operation.

LIGHT

The light assembly is composed of two parts - one (1) Lamp Assembly and one (1) Stanchion.

1. Remove the light assembly by loosening the setscrews on the light head.
2. The stanchion provided is 32.75" long. The tube can be cut to required length, if necessary.
3. Attach the 15' 18-Gauge 3-wire harness to the light assembly.
4. Connect switch to manufactures' recommendations.

NOTE:

This product is intended for mounting on Fiberglass Hardtops or Pilot House enclosures. All of these styles of tops offer various mounting options. The desired location in all cases is one that allows the mount to raise and lower completely with no obstructions to other components on the top.

The best way to determine proper placement of the mount is to (1) identify the location of all the other components on the

How to use

When boating with the Grand Slam 900 Masthead Anchor Light, easily raise and lower the light by turning the crank handle - either clockwise to lift or counterclockwise to lower. For going under bridges, trailering or storage, we recommend lowering the light to ensure it doesn't get damaged. When the light reaches its desired upright or fully lowered position, you can fold the crank handle flush into the base.

How to clean

Always use a mild, non-abrasive soap and fresh water. Thoroughly wash the aluminum with a soft towel or sponge to remove dried salt crystals and other contaminants. Rinse completely with fresh water.

Safe Cleaners

Mild dish washing liquid, specialty marine cleaners:

Sea Safe Boat Wash, Boat Wash Concentrate and Super Suds.

Safe marine lubricants:

CRC Corrosion Inhibitor, Corrosion Block and Get Some Extreme.

Harmful Cleaners

Bleach (Clorox, etc.) and mild abrasive cleaners:

Ajax, Comet, Soft Scrub, Rubbing Compounds, etc.

Strong cleaners:

409, Engine Degreasers, etc.

Acids of any type:

Such as Muriatic, naval jelly or aluminum acid.

top and (2) ensure its location will be good for operating the mount from under the top when cranking the handle while standing on the deck of the boat.

Once you have determined the location and the position of the mount, determine if you want the masthead anchor light to be visible from under the top when in its fully lowered position.

TECHNICAL SPECS

MASTHEAD ANCHOR LIGHT

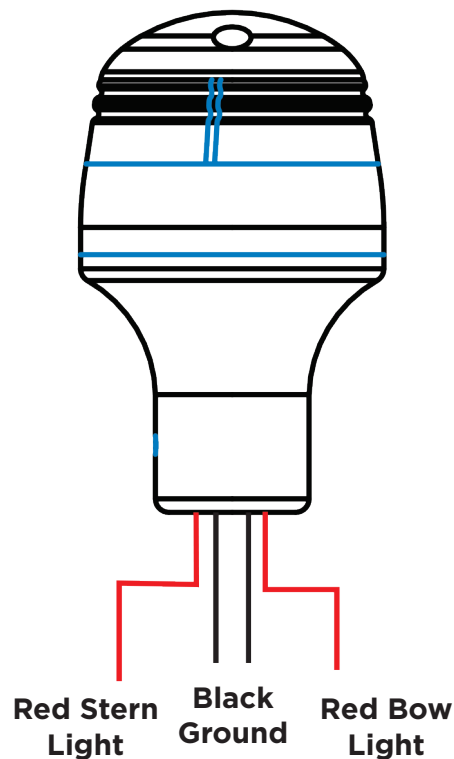
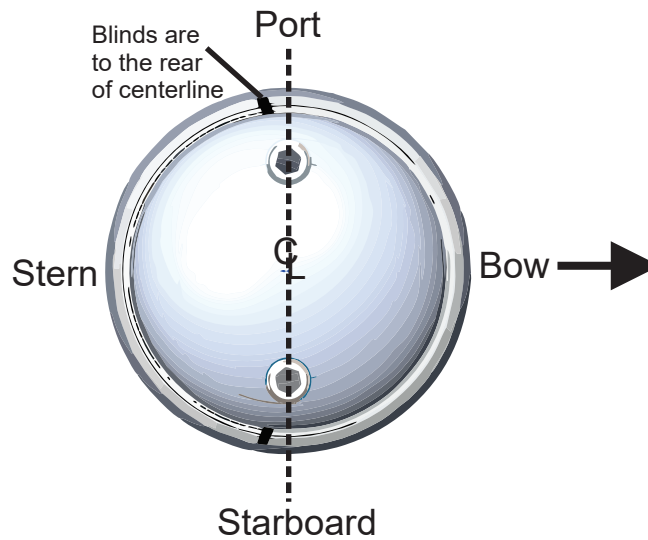



LEFT BLANK INTENTIONALLY



Need Support?

Contact Us



1.800.653.8568



support@tacomarine.com



tacomarine.com



50 NE 179th ST
Miami, FL. 33162



@tacomarine



@taco_marine

TACO Marine®



LEFT BLANK INTENTIONALLY



GS-900 Drill Template

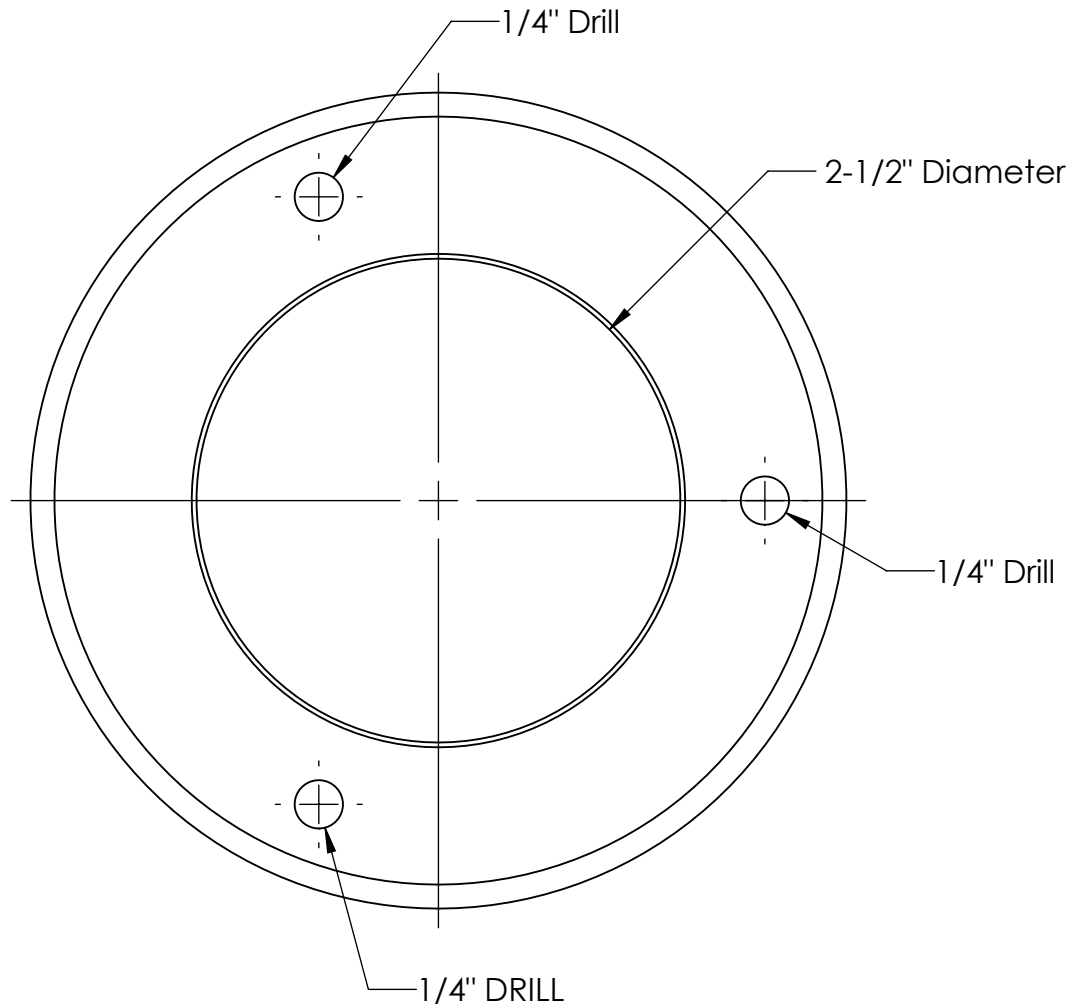

Please print at 100 percent for accurate sizing. Slight scaling may still occur. Therefore, before drilling, it is recommended that all template dimensions be measured for accuracy.

TACO[®]
MARINE

INST-GS-900