

SS264W Pair



2 Low-Profile Housings for Center-Consoles

Airmar has taken the SS270W wide-beam thru-hull and split it into a pair of Tilted Element™ transducers. One transducer handles 50 kHz while the other operates at 200 kHz. Now you can get all of the performance of the SS270W without a fairing. The low-profile design is perfect for fast, trailered, tournament, and sportfishing boats—especially center consoles.

See the Wider Picture

This transducer pair gives you four times the beamwidth at 200 kHz than other high-performance transducers. Since the width of the beams are the same at both frequencies, a split-screen fishfinder display will clearly show the same water column and bottom coverage. Fish may also appear as arches. More fish will be marked while cruising, trolling, drifting, or at anchor. Get the wider picture on your sounder with the SS264W pair.

- **Tuna/Marlin Fishermen**—Detect bait and gamefish in the upper water column that would go unseen with a traditional narrow-beam transducer.
- **Downrigger Fishermen**—Have the ability to see your downrigger ball and the lines attached to it. Get a closer look at a fish strike on your echosounder screen.
- **Jig Fishermen**—Seeing your jigs on the echosounder screen while bottom fishing can help avoid bottom hang-ups. Seeing a tuna attack your jigs on the echosounder display lets you reel up loose lines before it is too late.



Sensing Technology

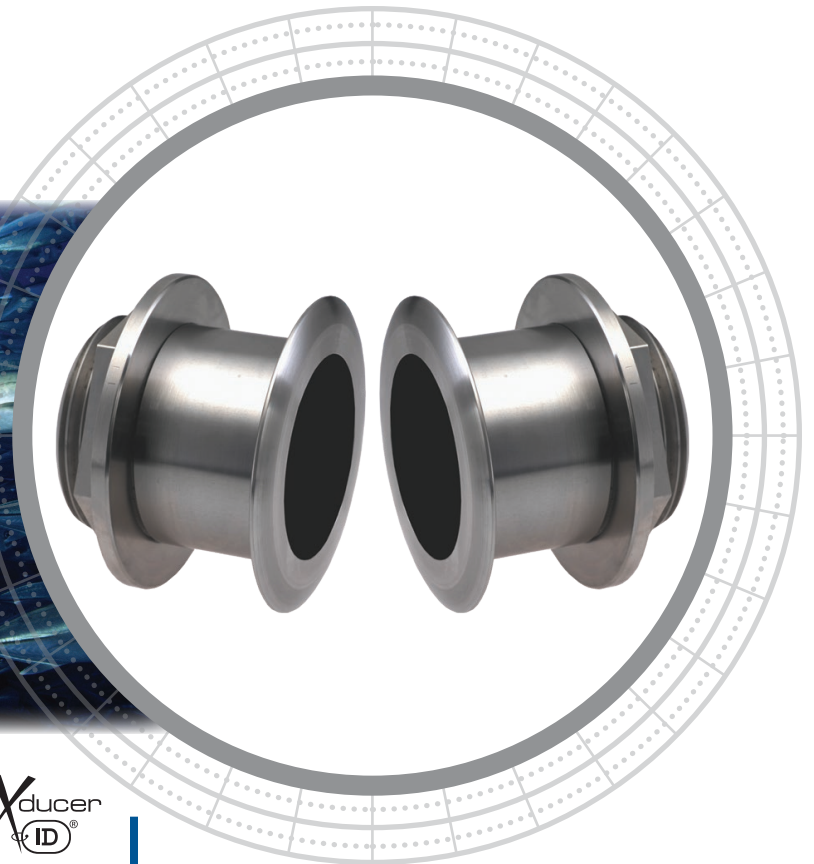

Tilted Element™ Pair Thru-Hull Wide-Beam 1 kW

Fishing Applications

- Blue-water trolling using both 50 kHz and 200 kHz
- Bait and game fish marking in shallow to mid-water
- Wreck and structure finding on the continental shelf
- Vertical deep jigging
- Downrigger fishing in saltwater or deep-water lakes

Features

- Consists of two transducers (purchased separately):
 - SS264 50 kHz wide-beam
 - SS264 200 kHz wide-beam
- Transducers must be purchased separately for dual-frequency operation or individually as a single-frequency unit
- Fixed 20° tilted version for 16° to 24° hull deadrise
- Fixed 12° tilted version for 8° to 15° hull deadrise
- Fixed 0° tilted version for 0° to 7° hull deadrise
- Provides 4 times the beamwidth at 200 kHz than other high-performance transducers
- Identical wide 25° beamwidths at 50 kHz and 200 kHz
- No affect on your boats running performance
- Low-profile protrusion below the hull
- Depth and fast-response water-temperature sensor
- Boat Size: 8 m to 11 m (25' to 35')

www.airmar.com

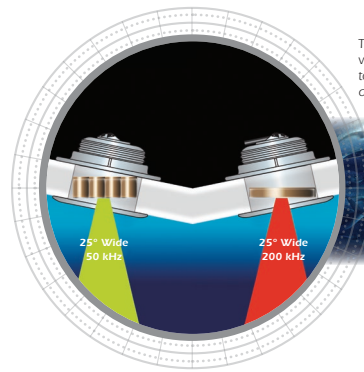

The high-performance ceramic elements are tilted inside the housing, which compensates for your boat's deadrise. This aims the beams straight toward the bottom, resulting in stronger echo returns and more accurate depth readings.

SS264W Pair



Technical Information

50 kHz-AWIq / 200 kHz-BM

Number of Elements and Configuration		
Beamwidth (@-3 dB)	25°	25°
RMS Power (W)	1 kW	1 kW
TVR	161 dB	167 dB
RVR	-175 dB	-194 dB
FOM	-19 dB	-27 dB
Q	4	15
Impedance	200 Ω	90 Ω

MAXIMUM DEPTH RANGE

50 kHz	200 kHz
400 m to 610 m (1,350' to 2,000')	100 m to 180 m (330' to 600')

BEAM DIAMETER VS DEPTH

Depth	50 kHz	200 kHz
9 m (30')	4 m (13')	4 m (13')
30 m (100')	14 m (45')	14 m (45')
122 m (400')	55 m (180')	55 m (180')
305 m (1,000')	137 m (450')	137 m (450')

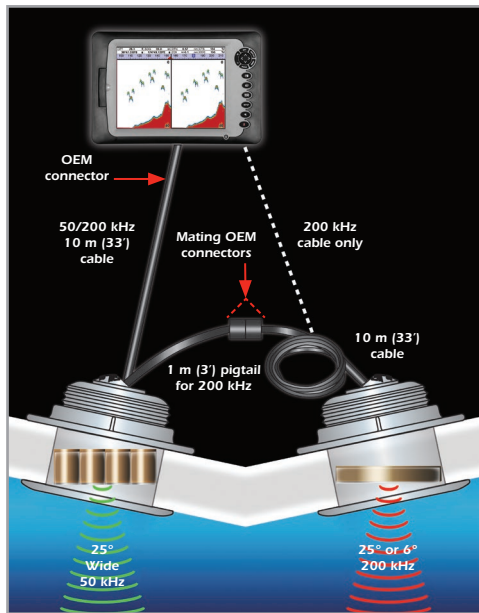

SS264W Pair wiring installation

SPECIFICATIONS

Weight: 2.7 kg (6 lb)
Hull Deadrise: Up to 24°
Acoustic Window: Urethane

DIMENSIONS

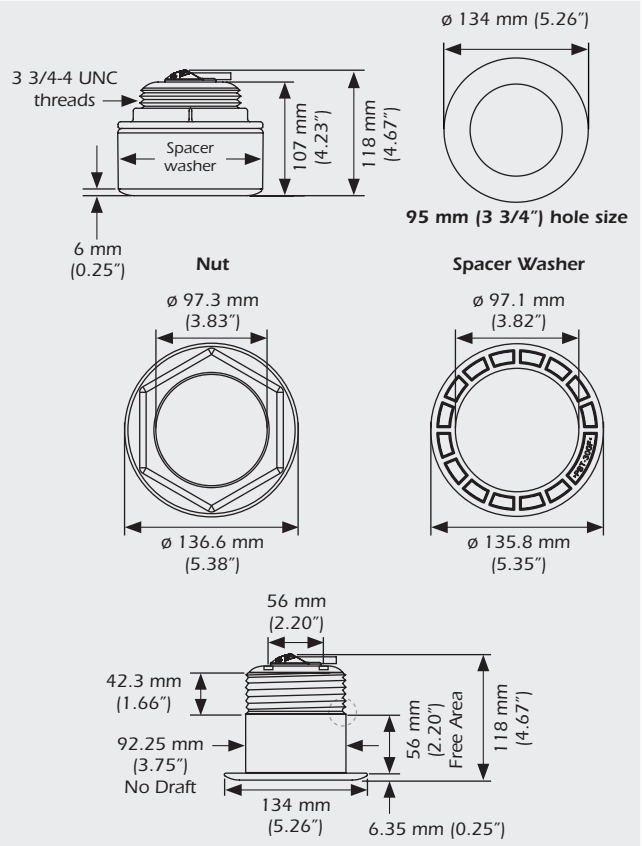

Directivity Patterns

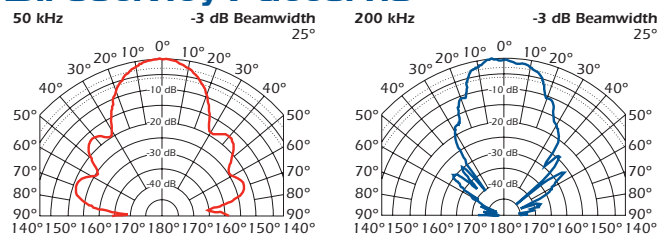

The 200 kHz transducer can be added to existing B260 or M260 installations (switchbox is needed) for the ultimate 200 kHz wide and narrow-beam combination. This gives you the ability to switch 200 kHz transducers based on the type of fishing on a given day.