

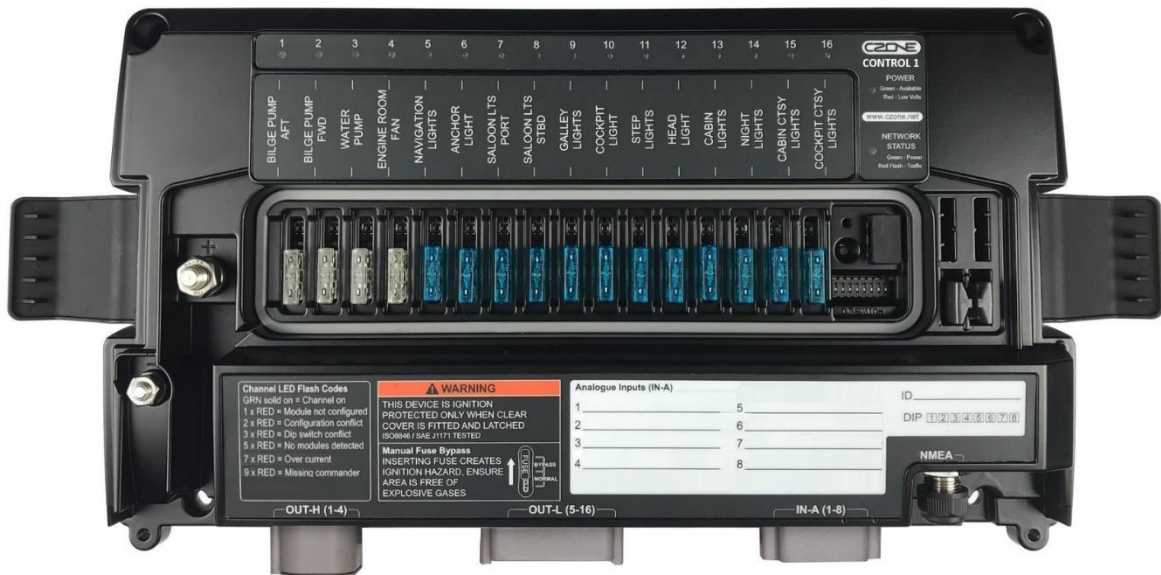

# Control 1

## USER AND INSTALLATION MANUAL

V1.0



### Copyright

This document is copyright 2019 under the Creative Commons agreement. Rights are granted to research and reproduce elements of this document for non-commercial purposes on the condition that BEP is credited as the source. Electronic re-distribution of the document in any format is restricted, to maintain quality and version control.

### Important

BEP strives to ensure all information is correct at the time of printing. However, the company reserves the right to change without notice any features and specifications of either its products or associated documentation.

**Translations:** In the event that there is a difference between a translation of this manual and the English version, the English version should be considered the official version.

It is the owner's sole responsibility to install and operate the device in a manner that will not cause accidents, personal injury or property damage.

## TABLE OF CONTENTS

<b>1</b>	<b>GENERAL INFORMATION</b>	<b>5</b>
1.1	Use of this manual	5
1.2	Guarantee Specifications	5
1.3	Quality	5
1.4	Validity Of This Manual	5
1.5	Liability	5
1.6	Changes To The Combined Output Interface	5
<b>2</b>	<b>SAFETY AND INSTALLATION PRECAUTIONS</b>	<b>6</b>
2.1	Warnings And Symbols	6
2.2	Use For Intended Purpose	6
2.3	Organizational Measures	6
2.4	Maintenance And Repair	6
2.5	General Safety and Installation Precautions	6
<b>3</b>	<b>OVERVIEW</b>	<b>7</b>
3.1	Description	7
3.2	Features	7
3.3	Control 1 Overview	8
3.4	Led Indicators	9
3.5	USB Port	10
3.5.1	General Requirements & Tips	10
3.5.2	Reading Configuration From Network	10
3.5.3	Writing Configuration To Network	10
3.5.4	Updating Device Firmware	10
3.6	System Example	12
<b>4</b>	<b>INSTALLATION</b>	<b>13</b>
4.1	Things You Need	13
4.2	Environment	13
4.3	Planning	14
4.4	Deutsch connector kit	15
4.5	Mounting	16
4.6	Connections	16
4.7	Labels & Fuses	19
4.8	Insert Fuses	19
4.9	Set Dipswitch	20
4.10	Initial Power Up	20
<b>5</b>	<b>SPECIFICATIONS</b>	<b>21</b>
5.1	Technical Specifications	21
5.2	NMEA 2000 PGN's	21
5.3	Dimensions	22

---

**6 ORDERING INFORMATION****23****Table of Figures**

Figure 1. Control 1 with Cover .....	8
Figure 2. Control 1 without Cover .....	8
Figure 3. LED Indicators .....	9
Figure 6. CZone Control 1 System Example .....	12
Figure 7. Deutsch HDT-48-00 Crimp Tool .....	13
Figure 8. Output Channel Specifications .....	14
Figure 9. Control 1 Bilge Pump Wiring Example.....	14
Figure 10. Control 1 Deutsch Connector Kit Parts.....	15
Figure 11. Mounting Screw Locations.....	16
Figure 12. Control 1 Connections .....	16
Figure 14. Fuses In Normal Operation.....	19
Figure 15. Setting Dipswitch .....	20
Figure 16. Control 1 Dimensions.....	22

# 1 GENERAL INFORMATION

## 1.1 USE OF THIS MANUAL

Copyright © 2019 BEP Marine. All rights reserved. Reproduction, transfer, distribution or storage of part or all of the contents in this document in any form without the prior written permission of BEP Marine is prohibited. This manual serves as a guideline for the safe and effective operation, maintenance and possible correction of minor malfunctions of the Control 1, called Control 1 further in this manual.

This manual is valid for the following models:

Description	Part number
CZONE CONTROL 1 INTERFACE	80-911-0122-00

It is obligatory that every person who works on or with the Control 1 is completely familiar with the contents of this manual, and that he/she carefully follows the instructions contained herein.

Installation of, and work on the Control 1, may be carried out only by qualified, authorized and trained personnel, consistent with the locally applicable standards and taking into consideration the safety guidelines and measures (chapter 2 of this manual). Please keep this manual in a secure place!

## 1.2 GUARANTEE SPECIFICATIONS

BEP Marine guarantees that this unit has been built according to the legally applicable standards and specifications. Should work take place which is not in accordance with the guidelines, instructions and specifications contained in this Installation manual, then damage may occur and/or the unit may not fulfil its specifications. All of these matters may mean that the guarantee becomes invalid.

## 1.3 QUALITY

During their production and prior to their delivery, all of our units are extensively tested and inspected. The standard guarantee period is two years.

## 1.4 VALIDITY OF THIS MANUAL

All of the specifications, provisions and instructions contained in this manual apply solely to standard versions of the Combined Output Interface delivered by BEP Marine.

## 1.5 LIABILITY

BEP can accept no liability for:

- Consequential damage due to use of the Control 1. Possible errors in the manuals and the results thereof

**CAREFUL!** Never remove the identification label

Important technical information required for service and maintenance can be derived from the type number plate.

## 1.6 CHANGES TO THE COMBINED OUTPUT INTERFACE

Changes to the Control 1 may be carried out only after obtaining the written permission of BEP.

---

## 2 SAFETY AND INSTALLATION PRECAUTIONS

### 2.1 WARNINGS AND SYMBOLS

Safety instructions and warnings are marked in this manual by the following pictograms:



#### CAUTION

Special data, restrictions and rules with regard to preventing damage.



#### WARNING

A WARNING refers to possible injury to the user or significant material damage to the Control 1 if the user does not (carefully) follow the procedures.



A procedure, circumstance, etc, which deserves extra attention.

### 2.2 USE FOR INTENDED PURPOSE

1. The Control 1 is constructed as per the applicable safety-technical guidelines.
2. Use the Control 1 only:
  - In technically correct conditions
  - In a closed space, protected against rain, moisture, dust and condensation
  - Observing the instructions in the installation manual



**WARNING** Never use the Control 1 in locations where there is danger of gas or dust explosion or potentially flammable products!

3. Use of the Control 1 other than mentioned in point 2 is not considered to be consistent with the intended purpose. BEP Marine is not liable for any damage resulting from the above.

### 2.3 ORGANIZATIONAL MEASURES

The user must always:

- Have access to the user's manual and be familiar with the contents of this manual

### 2.4 MAINTENANCE AND REPAIR

- Switch off supply to the system
- Be sure that third parties cannot reverse the measures taken
- If maintenance and repairs are required, only use original spare parts

### 2.5 GENERAL SAFETY AND INSTALLATION PRECAUTIONS

- Connection and protection must be done in accordance with local standards
- Do not work on the Control 1 or system if it is still connected to a power source. Only allow changes in your electrical system to be carried out by qualified electricians
- Check the wiring at least once a year. Defects such as loose connections, burned cables, etc. must be corrected immediately

## 3 OVERVIEW

### 3.1 DESCRIPTION

The Control 1 combines multiple input and output devices in to one module, minimizing installation, interconnections and footprint. The Control 1 incorporates many of the core features and benefits of the fully featured Combination Output Interface (COI), but has been re-engineered to offer improved cost-per-channel value. The Control 1 features the same rugged design as the fully featured COI with IPX5 water ingress protection and complete mechanical fuse and bypass on all circuits as required by ABYC/CE. Industry standard Deutsch connectors provide "plug and play" installation.

### 3.2 FEATURES

- Complete CZone Control and Monitoring system in a single box
  - Modular design provides system options for wide range of vessels & RV's
  - Compatible with marine multi-function and black box chartplotter/fishfinders
  - Equipped with advanced core CZone feature set
  - ABYC compliant ATC fusing and mechanical bypass for redundancy
  - PWM light dimming capability & smooth start
  - Monitor tank levels, battery volts, temperature and pressure using industry standard sensors
  - Bilge Pump Run Detection allows pump control and monitoring from a single wire
  - Status LED's for all outputs, DC supply & NMEA2000
  - Additional volt monitoring on main DC connection
  - In-built load shedding allows non-necessary loads to be turned off to preserve battery life
  - USB port allows full system firmware & config updates (no PC or adapters required)
-

3.3 CONTROL 1 OVERVIEW

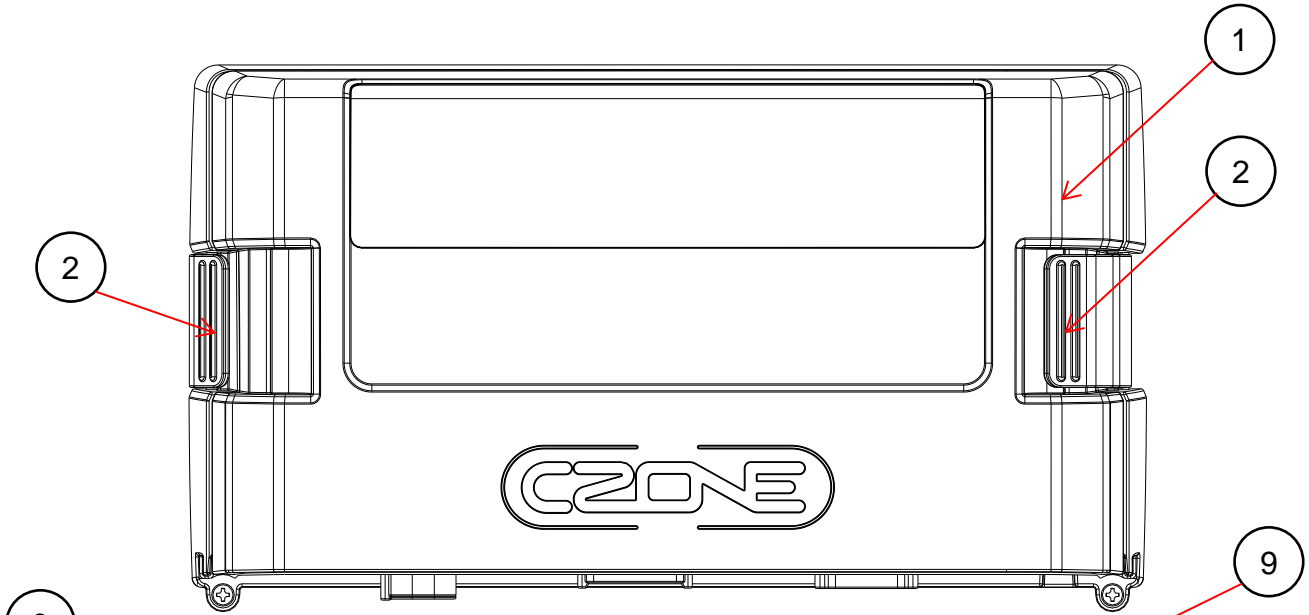

Figure 1. Control 1 with Cover

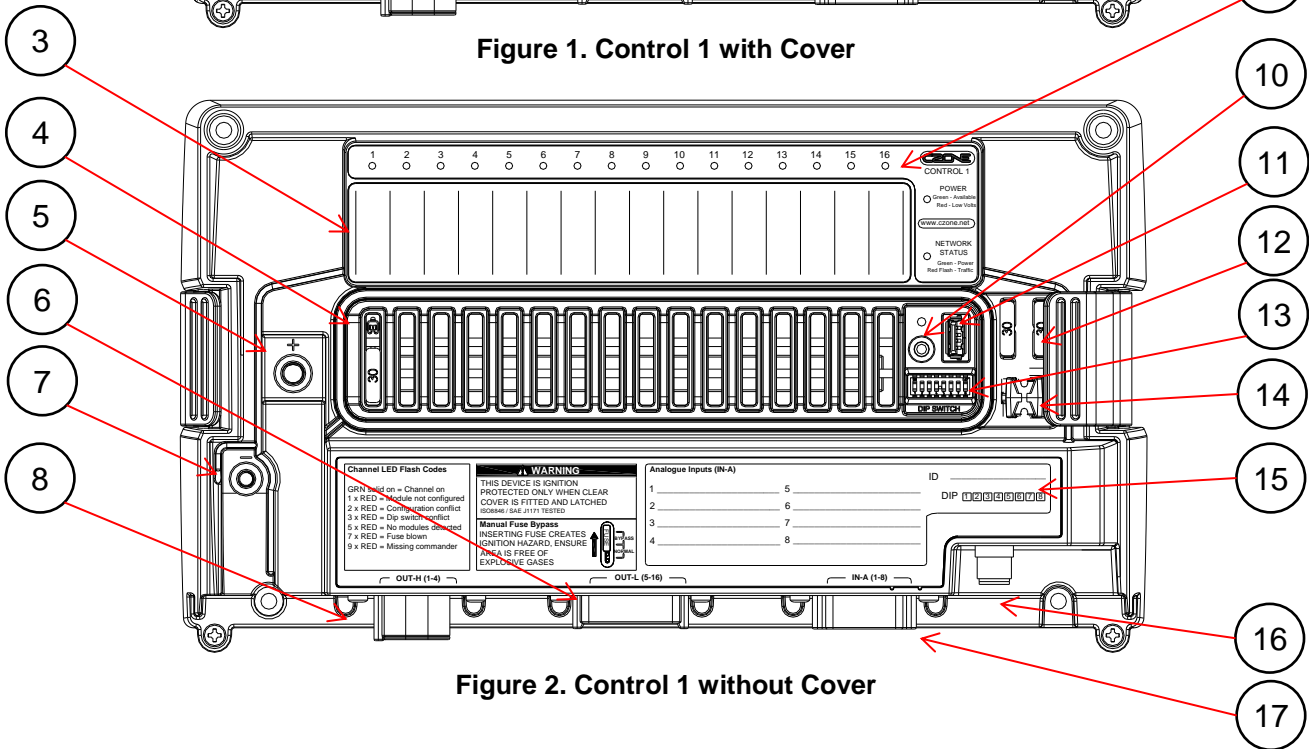

Figure 2. Control 1 without Cover

- |                                   |  |
|-----------------------------------|--|
| 1. Top Cover                      | 10. USB Programing Button & Status LED |
| 2. Clips for Top Cover Removal    | 11. USB Port                           |
| 3. Circuit Label                  | 12. Spare Fuse Positions               |
| 4. Circuit Fuses                  | 13. Dipswitch                          |
| 5. Main Positive Stud             | 14. Fuse Picker                        |
| 6. Low Current Output Connector   | 15. Fault Code/Input Label             |
| 7. Negative Stud                  | 16. NMEA 2000 Connector (5-pin)        |
| 8. High Current Output Connector  | 17. Analogue Input Connector           |
| 9. Circuit Status Indicator Label |  |



### 3.4 LED INDICATORS

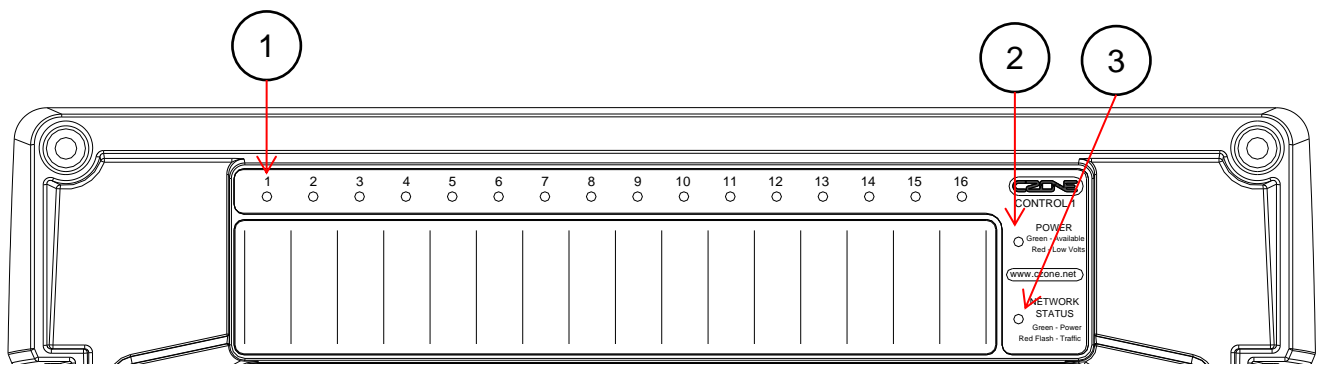

Figure 3. LED Indicators

#### 1. Circuit Status LED's

<u>Colour</u>	<u>Description</u>
Extinguished	Channel Off
Green Solid On	Channel On
1 Red Flash	Module Not Configured
2 Red Flash	Configuration Conflict
3 Red Flash	DIP Switch Conflict
5 Red Flash	No Modules Detected
7 Red Flash	Over Current
9 Red Flash	Missing Commander

#### 2. Power LED

<u>Colour</u>	<u>Description</u>
Extinguished	Power Disconnected
Green	Power Available (>12V for 12V System, >20V for 24V System)
Red	Low Volts (<12V for 12V System, <20V for 24V System)

#### 3. Network Status LED

<u>Colour</u>	<u>Description</u>
Extinguished	Network Power Disconnected
Green	Network Power Connected
Red Flash	Network traffic

## 3.5 USB PORT

The USB port on the Control 1 allows system software updates and configuration files to be loaded from a USB Memory Stick.

### 3.5.1 General Requirements & Tips

- Make sure the USB drive is FAT32 formatted.
- USB drive sizes up to 32GB are recommended.
- Most USB brands have been verified up to 32GB in size, including Strontium, Sandisk, Toshiba, Verbatim, Kingston, Samsung, Apacer etc.
- For USB drives 64GB and above only a limited number of devices from Kingston have been verified for operation.
- It is best, but not necessary, to use an empty USB drive for these operations.

### 3.5.2 Reading Configuration From Network

To read the existing configuration from the network to the USB drive you must:

1. Insert a USB drive with NO existing (\*.zcf or \*.czfwf) files in the root folder.
2. Press the USB button for 5sec or until the LED flashes RED.
3. Wait for the USB LED to turn solid green before removing it. This should take less than 20sec. Once done it will create/update 4 files:
  - a) \*.zcf - The configuration file read from the network
  - b) \*.csv - A spreadsheet listing information about the system and modules connected to the network
  - c) CZone.bak - A backup copy of the configuration file. This needs to be present when writing updated configuration back to the network
  - d) CZone USB Result.txt – A text file describing the result of the last operation performed, as well as these instructions

### 3.5.3 Writing Configuration To Network

To write the system configuration from the USB to the network you must:

1. Insert a USB drive in to the Control 1. The following files must be present in the root folder:
  - a) CZone.bak - This config file backup must match the existing system config before a config update can occur. This file is generated by copying the existing configuration to the USB as above.
  - b) \*.zcf - A single configuration file to be written to the network. If more than one file is present no update will occur.
  - c) No firmware update files (\*.czfwf).
2. Press the USB button for 5sec or until the LED flashes RED.
3. Wait for the USB LED to turn solid green before removing it. This should take less than 20sec.
4. Once the system configuration has been updated the following files will be created/updated:
  - a) \*.csv - A basic spreadsheet listing information about the system and modules connected to the network.
  - b) CZone USB Result.txt - A text file describing the result of the last operation performed, as well as these instructions.

### 3.5.4 Updating Device Firmware

To update firmware of devices on the network you must:

1. Insert a USB drive with the following files in the root folder: The following files must be present in the root folder:
  - a) \*.czfwf - A single CZone firmware update file to be used to update devices in the system.
  - b) No configuration files (\*.zcf).

2. Press the USB button for 5sec or until the LED flashes RED.
  3. Wait for the USB LED to turn solid green before removing it, this operation can take 10-40minutes depending on the number of different module types in the system. The Control 1 channel LEDs will sweep back and forth when looking for devices of a particular type to update. Once devices of a particular type are found and are being updated, the LEDs will indicate progress for this update.
  4. Once the firmware has been updated the following files will be created/updated:
    - a) \*.csv - A basic spreadsheet listing information about the system and modules connected to the network.
    - b) CZone USB Result.txt - A text file describing the result of the last operation performed, as well as these instructions.
-

3.6 SYSTEM EXAMPLE

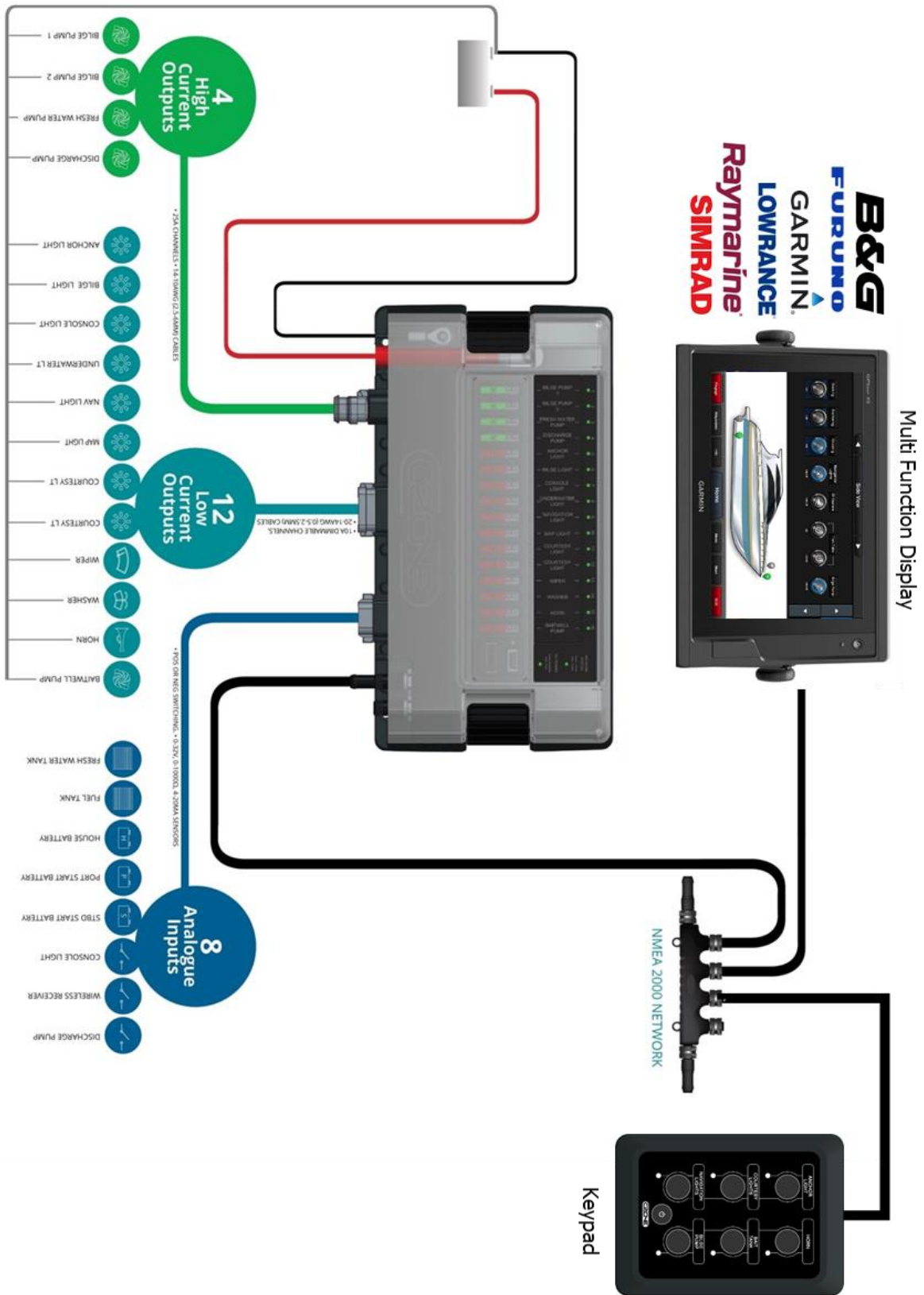

Figure 4. CZone Control 1 System Example

## 4 INSTALLATION

### 4.1 THINGS YOU NEED

- Control 1 Module & Top Cover (included)
- Deutsch Connector Kit (included with part # 80-911-0119-00)
- 4 x 8G or 10G (4mm or 5mm) self-tapping screws or bolts for mounting Control 1 to surface
- HDT-48-00 Deutsch crimp tool for crimping 0.5mm-4mm (20-12AWG) wire
- Duratool D03008 crimp tool or similar for crimping 6mm (10AWG) wire (optional)
- Appropriately rated ATC fuses for all circuits
- NMEA2000 drop cable and T-connector
- Screw driver and drill bits
- Electrical Tools



Figure 5. Deutsch HDT-48-00 Crimp Tool

### 4.2 ENVIRONMENT

Obey the following stipulations during installation:

- Ensure the Control 1 is located in an easily accessible location for quick access to fuses
  - Ensure indicator LED's are visible for troubleshooting
  - Ensure circuit label is fitted and all channels labelled correctly
  - The Control 1 must be mounted at least 50mm away from high current carrying conductors such as anchor winches, bow thruster cables, speakers, transformers and other high inductive loads.
  - Ensure Control 1 is mounted either vertically or horizontally
  - Ensure the bulkhead that the unit will be attached to is sufficiently strong to take the weight of the unit.
  - Ensure there is sufficient clearance above the Control 1 to allow the cover to be removed.
  - Ensure there is at least 10mm clearance around the sides and top of the Control 1
-

### 4.3 PLANNING

- Make a list of all inputs and outputs to be wired to the Control 1 and take note of the output channel ratings and functions as shown in Figure 6. Ensure loads are wired to the appropriate channel for the functionality required.
- All 25A channels have the option to alarm on detection of external voltage, useful for circuits such as Bilge Pumps with an external or “automatic” supply from a float switch. This feature reduces wiring by allowing control and feedback from a single wire. See Figure 7 for a Bilge Pump wiring example.
- For loads with a continuous current exceeding max channel current it is possible to parallel output channels up to 80A for OUT-H connector and 100A for OUT-L connector (do not parallel outputs between connectors).

	Plug Position	Max Current	External Alarm	Light Dimming
<b>Output 1</b>	OUT-H 1	25A	✓	✗
<b>Output 2</b>	OUT-H 2	25A	✓	✗
<b>Output 3</b>	OUT-H 3	25A	✓	✗
<b>Output 4</b>	OUT-H 4	25A	✓	✗
<b>Output 5</b>	OUT-L 1	10A	✗	✓
<b>Output 6</b>	OUT-L 2	10A	✗	✓
<b>Output 7</b>	OUT-L 3	10A	✗	✓
<b>Output 8</b>	OUT-L 4	10A	✗	✓
<b>Output 9</b>	OUT-L 5	10A	✗	✓
<b>Output 10</b>	OUT-L 6	10A	✗	✓
<b>Output 11</b>	OUT-L 7	10A	✗	✓
<b>Output 12</b>	OUT-L 8	10A	✗	✓
<b>Output 13</b>	OUT-L 9	10A	✗	✓
<b>Output 14</b>	OUT-L 10	10A	✗	✓
<b>Output 15</b>	OUT-L 11	10A	✗	✓
<b>Output 16</b>	OUT-L 12	10A	✗	✓

Figure 6. Output Channel Specifications

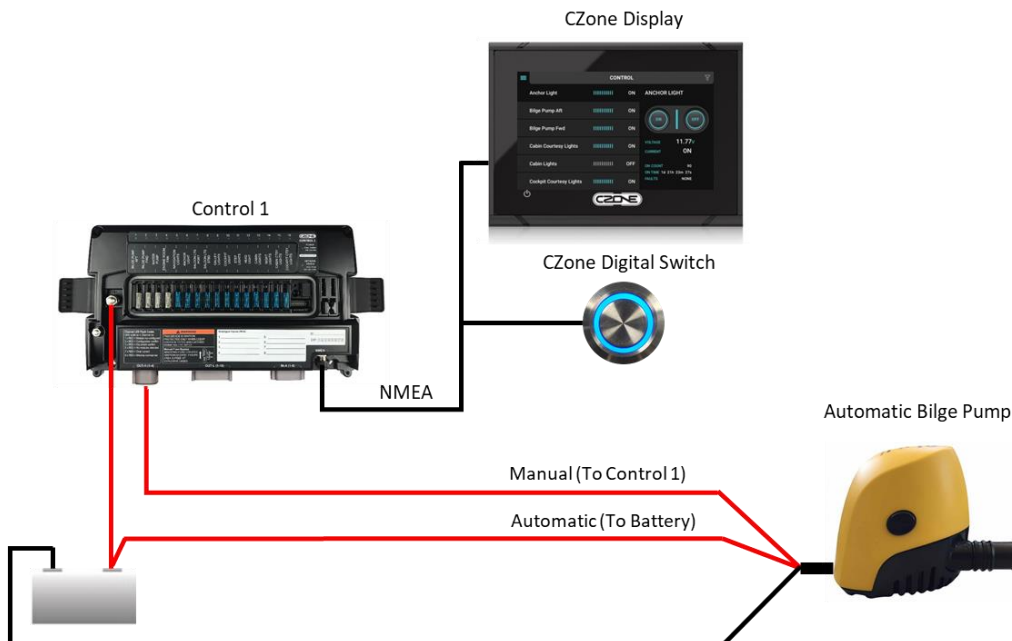

Figure 7. Control 1 Bilge Pump Wiring Example

#### 4.4 DEUTSCH CONNECTOR KIT

If you have purchased the Control 1 Deutsch connector kit (part # 80-911-0131-00), check all components are in the bag before proceeding.











<u>Image</u>	<u>Part Number</u>	<u>Description</u>	<u>Quantity</u>
	DTP06-4S	DEUTSCH DTP 4 POS MALE PLUG Accepts Size 12 Contacts	1
	WP-4S	DEUTSCH WEDGELOCK FOR DTP06-4S	1
	DT06-12SA	DEUTSCH DT 12 POS MALE PLUG Accepts Size 16 Contacts	1
	W12S	DEUTSCH LOCKING WEDGE FOR DT06-12S	1
	DT06-08SA	DEUTSCH DT 8 POS MALE PLUG Accepts Size 16 Contacts	1
	W8S	DEUTSCH LOCKING WEDGE FOR DT06-8S	1
	0462-203-12141	DEUTSCH SOCKET CONTACT SIZE 12 Suitable for 14-12AWG (2.0-4mm <sup>2</sup> ) cable	4
	0462-201-16141	DEUTSCH SOCKET CONTACT SIZE 16 Suitable for 20-16AWG (0.5-1.5mm <sup>2</sup> ) cable	20
	0462-209-16141	DEUTSCH SOCKET CONTACT SIZE 16 Suitable for 14AWG (2.0mm <sup>2</sup> ) cable	4
	1062-12-0222	STAMPED SOCKET NICKEL SIZE 12 Suitable for 10AWG (4-6mm <sup>2</sup> ) cable	4
	114017-ZZ	SEALING PLUG SIZE 12-16	12

Figure 8. Control 1 Deutsch Connector Kit Parts

## 4.5 MOUNTING

Figure 9. Mounting Screw Locations

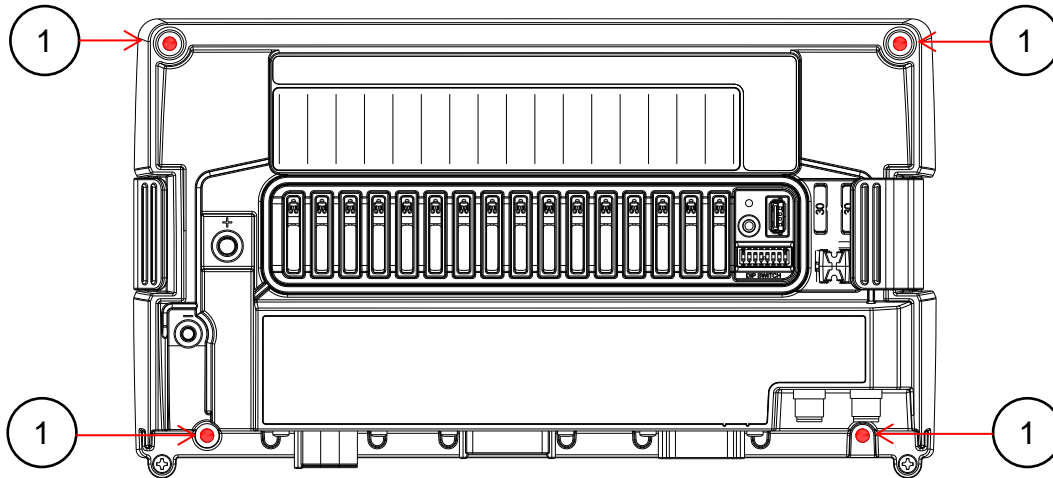

1. Remove the Control 1 top cover and locate the 4 mounting screw locators as shown in Figure 9
2. Place the Control 1 on a solid, flat surface.
3. Screw the Control 1 to the surface with 4 x 8G or 10G (4mm or 5mm) self-tapping screws or bolts.

## 4.6 CONNECTIONS

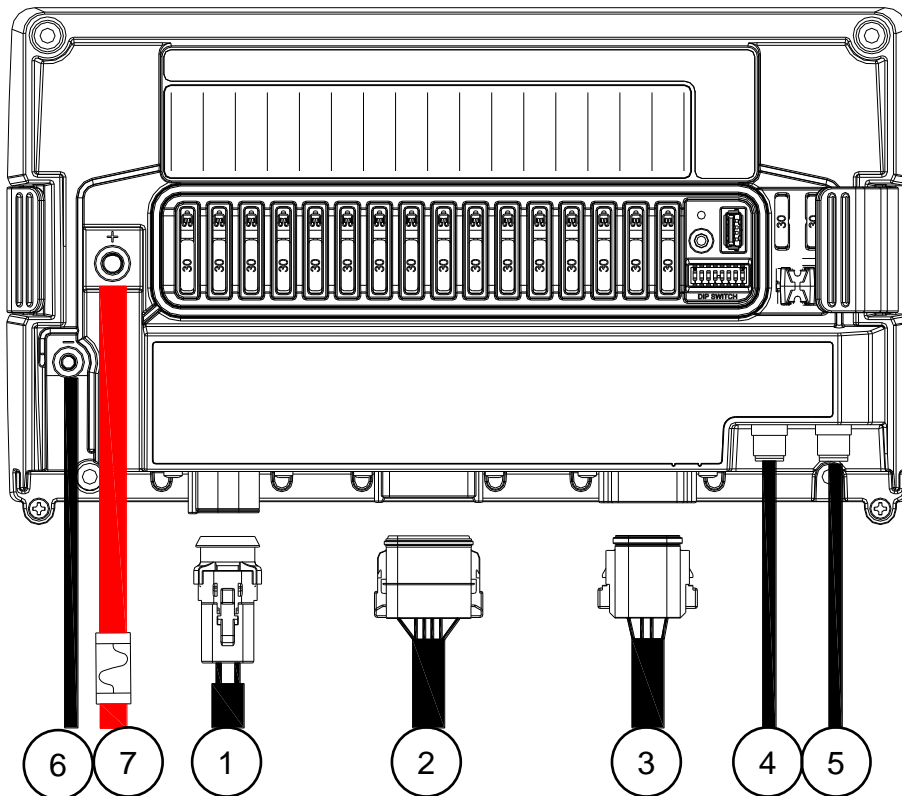

Figure 10. Control 1 Connections



### 1. Connect High-Current Outputs (OUT-H)

1. Referring to the load list, strip and crimp the High Current cables with the appropriate Deutsch contact and crimp tool.
2. Insert the contacts into the DTP06-4S plug following the plugs position numbers and secure using the locking wedge.
3. Any unused pins in the connector should be plugged with sealing plugs to maintain the IPX5 rating.
4. Insert the connector into the Control 1 and lock into place.
5. Load negatives are not connected to the Control 1, they must be connected to a common negative bus. Best wiring practice is to locate the negative connections close to the Control 1 so positive & negative wires run together minimizing magnetic fields.
6. Secure and neaten up the cables against the bulkhead to reduce the strain on the connectors.

### 2. Connect Low-Current Outputs (OUT-L):

1. Referring to the load list, strip and crimp the Low Current cables with the appropriate Deutsch contact and crimp tool.
2. Insert the contacts into the DT06-12SA plug following the plugs position numbers and secure using the locking wedge.
3. Any unused pins in the connector should be plugged with sealing plugs to maintain the IPX5 rating.
4. Insert the connector into the Control 1 and lock into place.
5. Load negatives are not connected to the Control 1, they must be connected to a common negative bus. Best wiring practice is to locate the negative connections close to the Control 1 so positive & negative wires run together minimizing magnetic fields.
6. Secure and neaten up the cables against the bulkhead to reduce the strain on the connectors.

### 3. Connect Analogue Inputs (IN-A)

1. The analogue inputs can be used to connect mechanical switches to control outputs (switch to pos or switch to neg) or analogue sensors (0-32V, 0-1000Ω or 4-20mA). CZone will convert analogue sensor values into NMEA 2000 digital sentences.
2. Referring to the input list, strip and crimp the Analogue Input cables with the appropriate Deutsch contact and crimp tool.
3. Insert the contacts into the DT06-08SA plug following the plugs position numbers and secure using the locking wedge.
4. Any unused pins in the connector should be plugged with sealing plugs to maintain the IPX5 rating.
5. Insert the connector into the Control 1 and lock into place.
6. Secure and neaten up the cables against the bulkhead to reduce the strain on the connectors.

### 4. Connect NMEA2000 network

1. Connect an NMEA2000 drop cable from the Control 1 to an NMEA2000 backbone.
  2. Ensure the NMEA2000 network is properly terminated and connected to a 12V power source (Do not power up network yet).
-

**5. Connect DC Negative**

1. Connect a 2.5mm<sup>2</sup> (12AWG) cable from the battery negative terminal or main negative bus to the Control 1's M6 negative stud.

**6. Connect DC Positive**

1. Connect an appropriately sized and fused cable from the battery positive terminal to the Control 1's M8 positive stud.
2. The positive cable must be of sufficient size to carry the maximum current of all loads connected to the Control 1 and have a fuse/circuit breaker rated to protect the cable, volt drop should be kept to a minimum.
3. Maximum recommended cable size is 70mm<sup>2</sup> (2/0). Cables larger than 70mm<sup>2</sup> (2/0) should be connected to a positive stud first with a link to the Control 1.
4. It is possible to connect two positive cables "back to back" on the positive stud for linking the supply on 2 or more Control 1's.

## 4.7 LABELS & FUSES

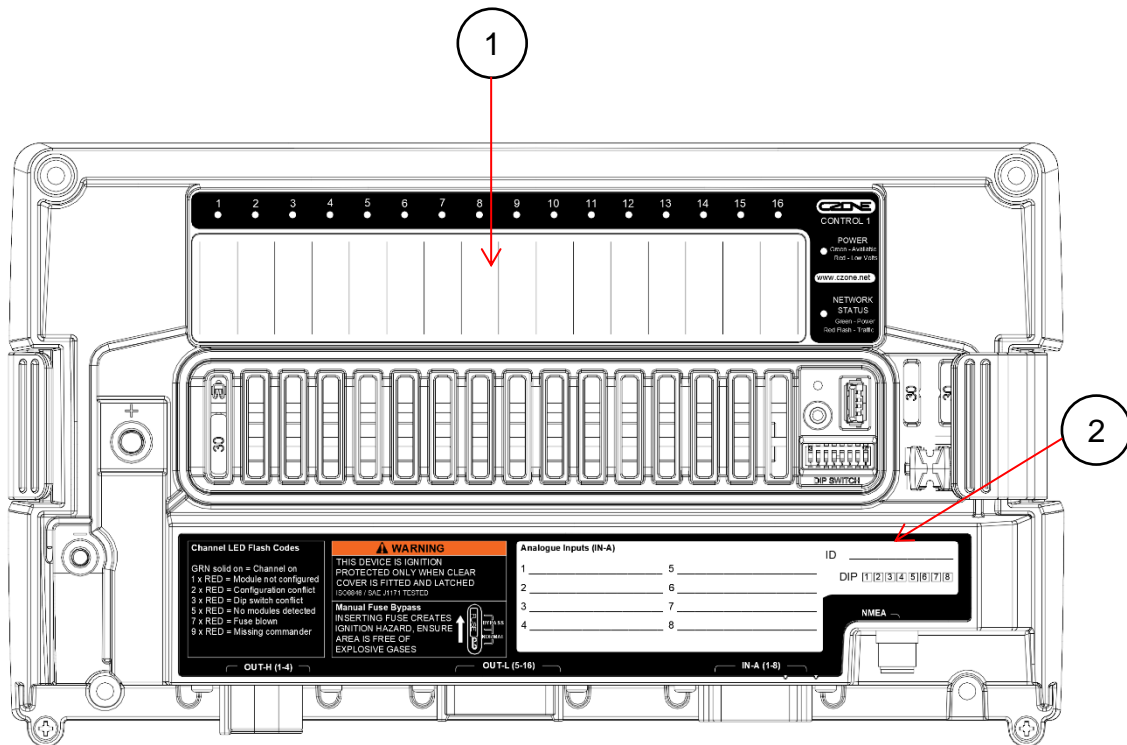

### 1. Label the Circuits

- Using a suitable label maker, print the output names (1-16) matching the load list and physical plug connections.

### 2. Label the Inputs

- Using a marker pen, write the analogue and digital input names matching the input list and physical plug connections.
- Write the Control 1 module number and location (i.e. Control 1 01 – Engine Room). This should match the module name in the configuration.
- Mark the dipswitch setting of the Control 1. This is usually assigned automatically when writing the configuration and needs to be unique for each module on the CZone system.

## 4.8 INSERT FUSES



Figure 11. Fuses In Normal Operation

**IMPORTANT:** The Control 1 is not software fused like the COI module, so it is imperative each ATC fuse is rated to protect the cable connected to the output. Failure in doing so may cause a fire hazard.

- Insert appropriately rated ATC fuses into the NORMAL operation (bottom) position of all fuse holders.

## 4.9 SET DIPSWITCH

- Using a small screwdriver carefully set the dipswitch on the Control 1. The dipswitch number must be unique for all modules on the CZone network and must match the dipswitch setting in the configuration to function correctly. The example in Figure 12 shows a dipswitch number of 01101100 where 0 = Off and 1 = On

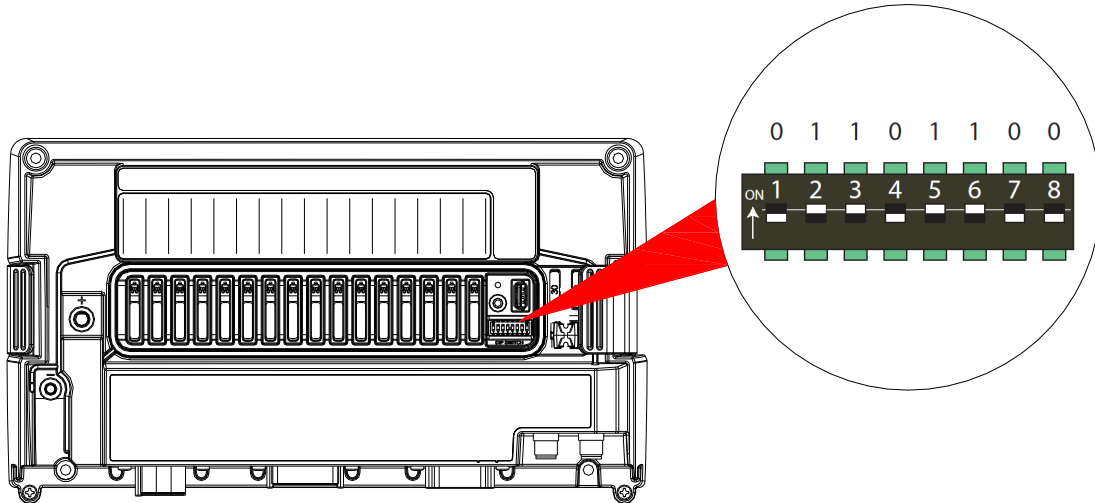

Figure 12. Setting Dipswitch

## 4.10 INITIAL POWER UP

1. Check all plugs are securely seated and connections are tight.
2. Ensure the Control 1's top cover is clipped securely in place and gasket is seated properly around fuses.
3. Power up the NMEA2000 network.
4. Check that the NMEA2000 Network LED lights up. It may also be flashing if other devices are present and transmitting data.
5. Turn the switch/circuit breaker on supplying the Control 1's main positive stud.
6. Check that the Power indicator LED is green.
7. Check the circuit's status LED's for each individual circuit. Refer to LED codes to diagnose any faults which need to be rectified.
8. Check the software version on the Control 1 with the CZone Configuration Tool and update if necessary.
9. Write configuration file to the Control 1 and the rest of the CZone modules on the system (Refer to the CZone Configuration Tool Instructions for details on how to configure the Control 1).
10. Test all inputs and outputs for configured functionality.

## 5 SPECIFICATIONS

### 5.1 TECHNICAL SPECIFICATIONS

Model	Control 1
Article numbers	80-911-0122-00
Manufacturer	BEP Marine New Zealand
Output Channels High	4 x 25A
Output Channels Low	12 x 10A Dimmable
Analogue Inputs	8 x Analogue Inputs: Positive or Negative Switching, 0-32 Volt, 0-1000 Ohm Resistance & 4-20mA Current
Additional Monitoring	1 x Voltage Sensors (Main Positive Stud)
Circuit Protection	ATC Fuse
Alarms	Fuse Blown, Fuse In Over-ride alarms
Maximum Continuous Current	150A @ 40°C (derating above 40°C)
NMEA 2000 Power Consumption	Operating (All Channels On) = 100mA @ 13.2V Operating (All Channels Off) = 75mA @ 13.2V
Power Supply	M8 (5/16") Stud Positive, M6 (1/4") Negative
Voltage	9-32V (with Power Available LED and Voltage Monitoring)
Circuit Bypass	Mechanical Protection/Bypass All Output Channels
Bilge Pump Circuits	4 x Channels High: Integrated manual control & pump running detection
Ingress Protection	IPx5 (mounted at 0°, +/-90°)
Communication	NMEA 2000
Weight	1.9kg
Certification	CE, ABYC, NMEA, ISO8846/SAEJ1171 Ignition Protected

### 5.2 NMEA 2000 PGN'S

NMEA 2000 PGN's sent from the Control 1

PGN Number	Description	Fields
127508	Battery Status	Battery Voltage
127505	Fluid Level	Fluid Level
130312	Temperature	Actual Temperature
130314	Pressure	Pressure
130316	Temperature, Extended Range	Actual Temperature

### 5.3 DIMENSIONS

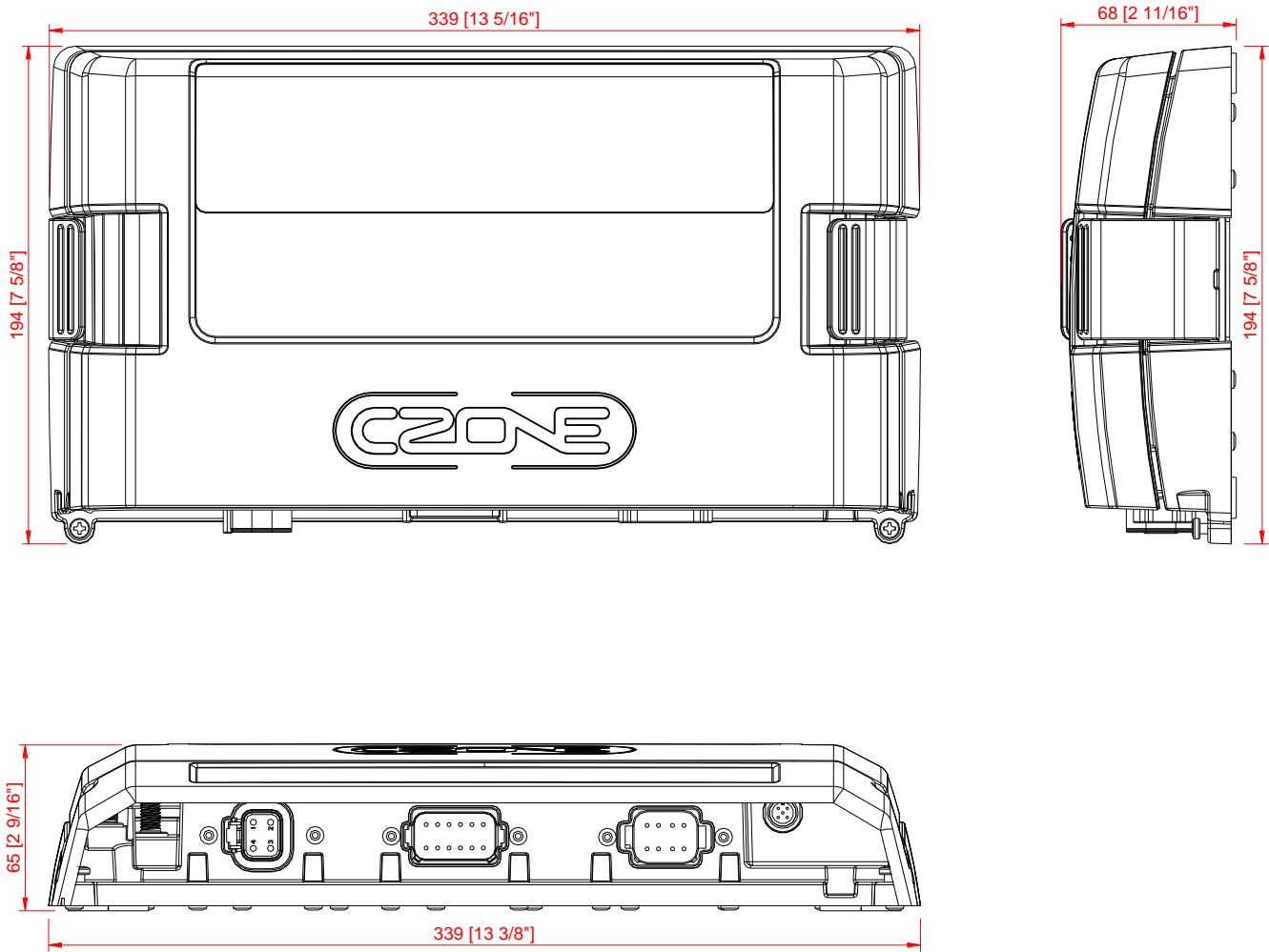

Figure 13. Control 1 Dimensions

## 6 ORDERING INFORMATION

### Control 1 Part Numbers and Accessories

<u>Part Number</u>	<u>Description</u>
80-911-0122-00	CZONE CONTROL 1 INTERFACE
80-911-0131-00	CZONE COI/CONTROL 1 DEUTSCH CONNECTOR KIT
80-911-0133-00	DEUTSCH CRIMP TOOL HDT-48-00