



## Professional Type Approved NMEA<sup>®</sup> 0183 Buffer Install/User Manual



## Contents

<b>Company Information</b> .....	<b>4</b>
<b>Important Notices</b> .....	<b>5</b>
Trademarks and Registered Trademarks.....	5
Fair Use Statement.....	5
Technical Accuracy.....	5
Product Registration.....	5
Product Guarantee.....	5
Product Disposal.....	5
<b>Product Overview</b> .....	<b>6</b>
Features.....	6
Example of a Typical PRO-NBF-1 Installation.....	6
Package Contents.....	6
<b>Installation Warnings</b> .....	<b>8</b>
<b>Mounting the PRO-NBF-1</b> .....	<b>9</b>
Bulkhead Mounting.....	9
DIN Rail Mounting.....	9
<b>Connecting Power to the PRO-NBF-1</b> .....	<b>10</b>
Figure 3 - Power Connection Diagram.....	10
<b>Connecting to the PRO-NBF-1 Ports</b> .....	<b>11</b>
Connecting an NMEA Talker.....	11
Connecting an NMEA Listener.....	11
Connecting an RS232 Device (PC) as a Talker.....	12
Connecting an RS232 Device (PC) as a Listener.....	12
<b>Troubleshooting Guide</b> .....	<b>14</b>
LED Indicators.....	14
Technical Support and the Returns Procedure.....	14
<b>Technical Specifications</b> .....	<b>15</b>
<b>PRO-NBF-1 Product Order Codes</b> .....	<b>16</b>

PAGE INTENTIONALLY LEFT BLANK

## Company Information

Active Research Ltd  
21 harwell Road  
Poole, Dorset  
UK, BH17 0GE

Telephone: +44 (0)1202 746682  
Email: [support@actisense.com](mailto:support@actisense.com)  
Web: [www.actisense.com](http://www.actisense.com)

## Important Notices

 The PRO-NBF-1 complies with the Electromagnetic Compatibility requirements according to EN60945:2002, DNVGL-CG-0339:2019 & IACS UR E10 Rev7. The unit should always be used in conjunction with appropriately approved shielded cable and connectors to ensure compliance. A declaration of conformity is available for download at [www.actisense.com](http://www.actisense.com). If the device to which this manual relates is to be installed within five metres of a compass, please refer to the 'Compass Safe Distance' section in the 'Technical Specifications' table.

## Trademarks and Registered Trademarks

Actisense® and the Actisense logo are registered trademarks of Active Research Limited. All other trademarks are the property of their respective owners.  
The NMEA® name and NMEA logo are copyright held by the NMEA. All uses in this manual are by permission and no claim on the right to the NMEA name or logo are made in this manual.

## Fair Use Statement

The contents of this manual may not be transferred or copied without the express written permission of Active Research Limited.  
Copyright © 2021 Active Research Ltd. All rights reserved.

## Technical Accuracy

To the best of our knowledge the information contained in this document was correct at the time it was produced. Active Research Ltd cannot accept liability for any inaccuracies or omissions.  
The products described in this manual and the specifications thereof may be changed without prior notice. Active Research Ltd cannot accept any liability for differences between the product and this document. To check for updated information and specifications please contact Active Research Limited.

Active Research Limited will not be liable for infringement of copyright, industrial property rights, or other rights of a third party caused by the use of information or drawings described in this manual.

## Product Registration

Please register your product via the online form [www.actisense.com/support/prodreg.html](http://www.actisense.com/support/prodreg.html).  
Your product package includes a unit serial number. Your registration will assist Actisense Support to link your product to your details, simplifying any future assistance you may require.

## Product Guarantee

All Actisense products are provided with a 3 year guarantee as standard. To activate the 5-year guarantee offered with this product please complete product registration online. If you suspect that the unit is faulty please refer to the **"Troubleshooting Guide" on page 14**.

It is a requirement of the guarantee that all installations of electronic equipment follow the NMEA 0400 specification. Any connection to a battery or power supply must meet the mandatory essential safety requirements that may be imposed by local regulatory agencies.



Actisense products are intended for use in a marine environment, primarily for below deck use. If a product is to be used in a more severe environment, such use may be considered misuse under the Active Research Limited guarantee.

## Product Disposal

Please dispose of this product in accordance with the WEEE Directive. The product should be taken to a registered establishment for the disposal of electronic equipment.

## Product Overview

The professional Actisense NMEA Buffer (PRO-NBF-1) distributes up to six identical data streams from a single source. Signals are buffered to ensure each receiver has the required voltage levels. Isolation on the input and each output allows non-isolated devices to be connected safely. The device is Type Approved, enabling installation on vessels where this is a requirement.

### Features

- Works automatically with any serial protocol, including NMEA 0183
- Works automatically at any baud rate up to 115200 Baud
- Opto-isolation on the input meets the latest NMEA 0183 specification
- ISO-Drive™ provides galvanic isolation on the outputs to prevent ground loops
- Compatible with all NMEA 0183 versions without requiring configuration
- Inputs and outputs compatible with RS422 and RS232 devices
- Bulkhead Mount and optional DIN Rail Mount
- Pluggable screw terminals for quick and easy installation
- Amplification of weak input signals
- Rugged stainless steel housing suitable for harsh environments
- Metal housing acts as an RF Shield
- Diagnostic LEDs for Power, Input and Output operation

PAGE INTENTIONALLY LEFT BLANK

## Package Contents

- 1 x PRO-NBF-1 with pluggable screw terminals.

## Available Accessories

- Screwless Terminals
- Strain Relief Bracket kit
- DIN Rail Mount kit

## Installation Warnings



All warnings and notices must be followed to ensure the correct operation of the PRO-NBF-1. Incorrect installation may invalidate the guarantee.

It is highly recommended that all of the installation instructions are read before commencing the installation. There are important warnings and notes throughout the manual that should be considered before the installation is attempted.

### Warning 1: Accuracy

The Actisense PRO-NBF-1 is designed to accurately transfer data from the input to its outputs. No data integrity checking is performed by the PRO-NBF-1. Any incomplete, inaccurate or corrupt data received on the PRO-NBF-1 input will be duplicated to the PRO-NBF-1 outputs. The accuracy of the data is dependant on the NMEA Talker or other source device that generated the data.

### Warning 2: Installation and Operation

This product must be installed and operated in accordance with the instructions provided. Failure to do so could result in personal injury, damage to your boat and/or poor product performance.

### Warning 3: Installation Code of Practice

When wiring the power supply to the PRO-NBF-1 ensure the isolation switch is off. Wiring the PRO-NBF-1 while the connection is live may damage the PRO-NBF-1 and is in breach of the guarantee. Any connection to a battery or power supply must meet the mandatory essential safety requirements that may be imposed by local regulatory agencies. All wiring should be in accordance with the requirements of the NMEA 0400 installation specification.

### Warning 4: Mounting Requirements

Select a flat location to mount the PRO-NBF-1. Mounting on a contoured surface may cause damage to the case.

Do not mount the PRO-NBF-1 while the device is powered.

Do not mount the PRO-NBF-1 while the cable harness is connected.

Note that the terminals are pluggable for easy disconnection when mounting or removing the PRO-NBF-1.

## Mounting the PRO-NBF-1

### Bulkhead Mounting

#### Method:

Actisense recommends the PRO-NBF-1 is installed using DIN rail for the most secure installation. However, the PRO-NBF-1 can be secured to a bulkhead using the four screw holes on either side of the PRO-NBF-1.

### DIN Rail Mounting

#### Method:

Install the DIN rail in the desired location.

Attach the PRO-NBF-1 to the DIN rail as shown in the diagrams below.

Ensure the PRO-NBF-1 sits flush against the DIN rail.

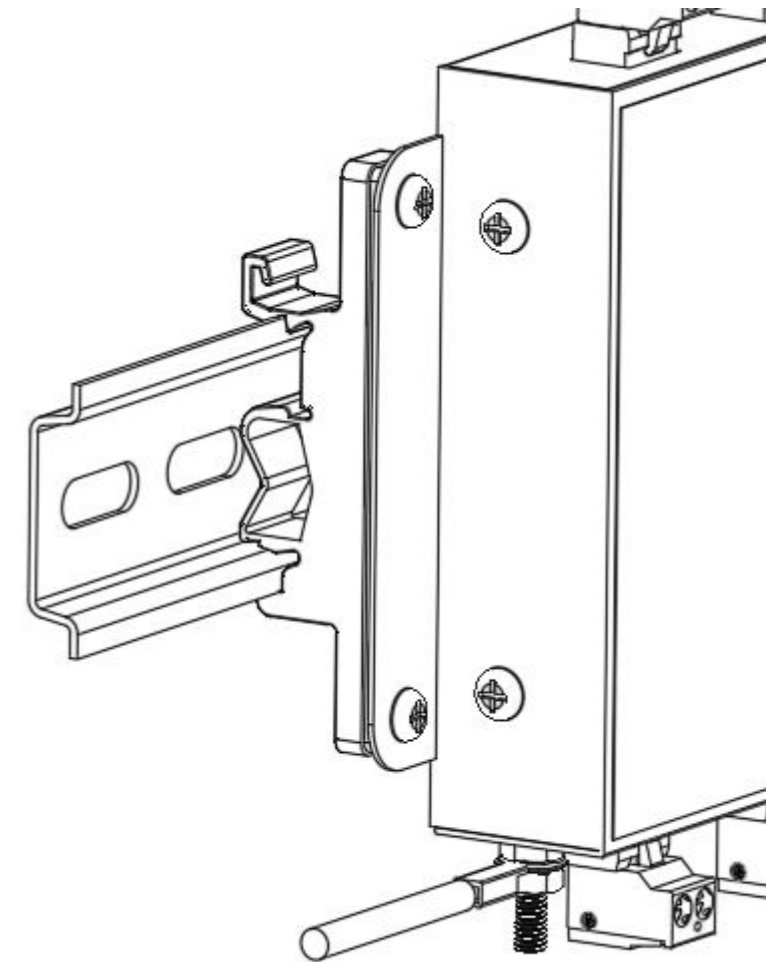

## Terminals

The PRO-NBF-1 comes with 2-way and 3-way screw connectors. Screwless terminals are available as an accessory. PRO-NBF-1 connectors are pluggable, meaning they can be easily removed for quick and simple wire installation without the need to unmount the PRO-NBF-1 from its installed location.

### Screw Connector

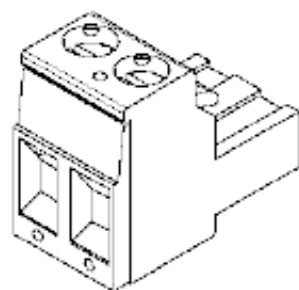

2-way

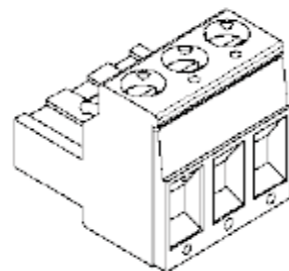

3-way

### Screwless Connector (Supplied as an accessory)

Open the clamp inside the screwless connector by pressing down on the orange button with a small (2mm) flat headed screwdriver. This will allow the wire to be inserted. For best connections do not twist the wire strands. Release the orange button to lower the clamp on to the wire strands for a secure termination.

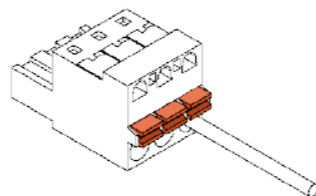
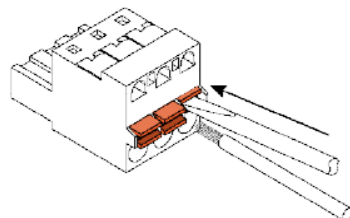

### Connecting Power to the PRO-NBF-1

- The PRO-NBF-1 requires a power source providing between 10 and 35 Volts DC.
- The PRO-NBF-1 '+' Terminal should be connected to the vessel power supply '+' Terminal with the correctly rated fuse (in accordance with NMEA 0400 Standard)
- The PRO-NBF-1 Negative '-' Terminal should be connected to the vessels DC Ground Plate.
- The PRO-NBF-1 should only be used with standard negative ground DC systems.

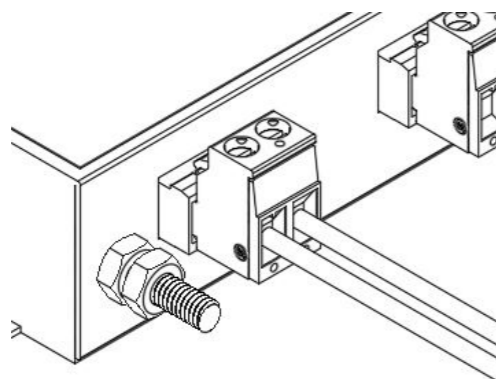

## NMEA 0183 Listener and Talker Designations

The NMEA have updated the NMEA 0183 specification to ensure a consistent naming convention is used for labelling ports. The designation follows the same rules as used for Rx and Tx labelling but uses Talker and Listener instead. The input / receiving (Rx) port will be labelled as a 'Listener' port. The output / transmitting (Tx) port will be labelled as a 'Talker' port. When a port is labelled 'Listener' it is an input and when it is labelled 'Talker' it is an output.

### Connecting to the PRO-NBF-1 Listener Port (INPUT)

The input to the PRO-NBF-1 is labelled 'Listener' and this is where the NMEA Talker should be connected:

- Connect the PRO-NBF-1 Listener A/+ to the positive data line of the NMEA Talker. When connecting RS232 or NMEA 0183 version 1 Talkers, this will be the Tx / data out of the Talker.
- Connect the PRO-NBF-1 Listener B/- to the negative data line of the NMEA Talker. When connecting RS232 or NMEA 0183 version 1 Talkers, this will be the ground / common of the Talker. Always check the manual for the correct wiring.

**Note:** Only one NMEA Talker can be connected to the PRO-NBF-1 Listener (Input) ports.

**Note:** The NMEA Listener (Input) ports are fully isolated and is compatible with all versions of NMEA 0183 and with RS422, RS232 and RS485 voltage levels.

### Connecting to the PRO-NBF-1 Talker Port (OUTPUT)

The output to the PRO-NBF-1 is labelled 'Talker' and this is where the NMEA Listener should be connected:

- Connect the PRO-NBF-1 Talker A/+ to the positive data line of the NMEA Listener. When connecting RS232 or NMEA 0183 version 1 Listener, this will be the Rx / Data In of the Listener.
- Connect the PRO-NBF-1 Talker B/- to the negative data line of the NMEA Listener. When connecting RS232 or NMEA 0183 version 1 Talkers, this will be the ground / common of the Listener.

**Care should be taken when creating this connection. It is only possible to wire B/- into GND thanks to Actisense ISO-Drive technology providing protection. Consult the relevant User Manual if not using Actisense Products for wiring instructions.**

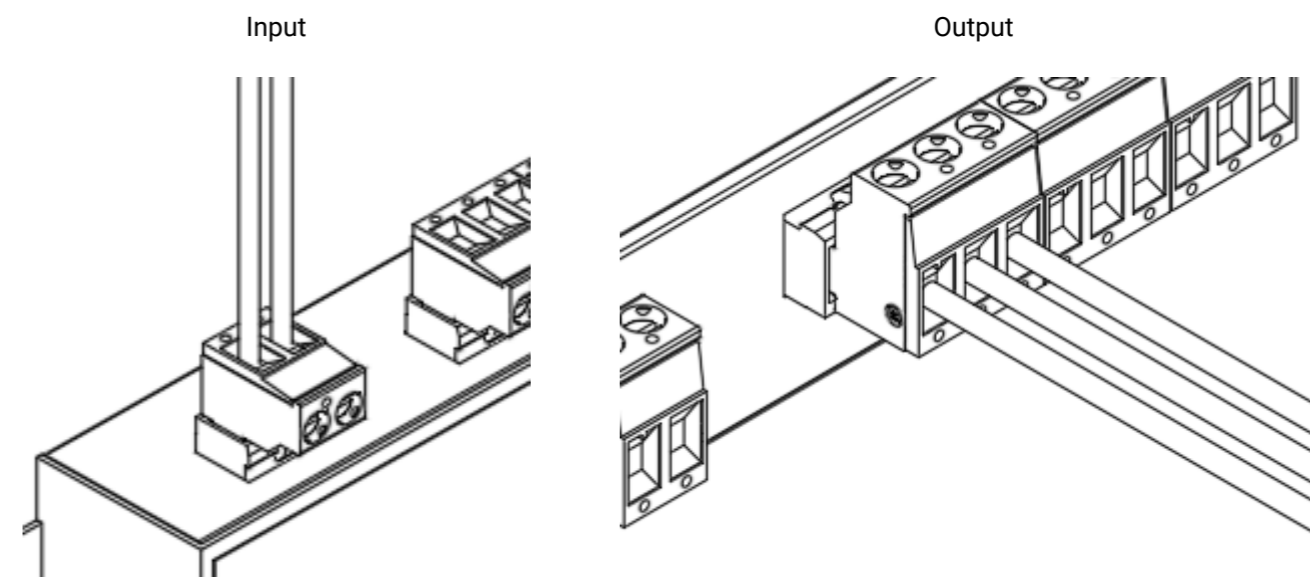

**Connecting an RS232 Device (PC) as a Talker**

A PC can be connected the same way as an RS232 type NMEA Talker.

- Connect the NBF-3 Listener A/+ to the Tx pin of the RS232 connector. (PIN 3)
- Connect the NBF-3 Listener B/- to the Ground pin of the RS232 connector. (PIN 5)

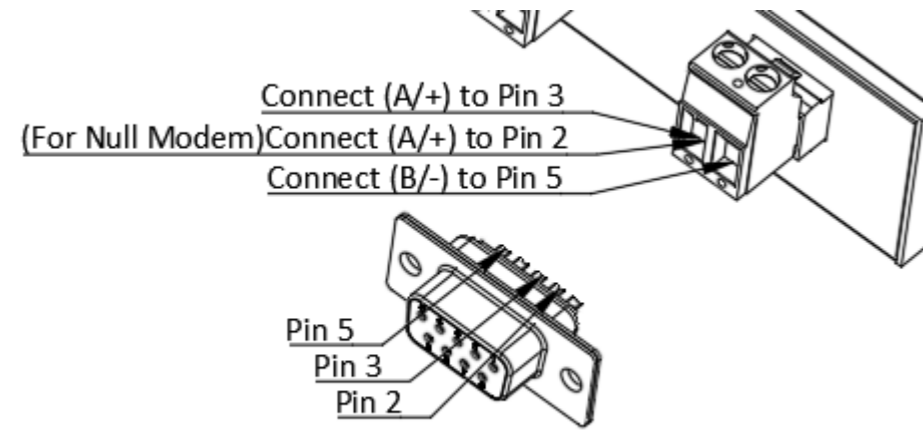

**Connecting an RS232 Device (PC) as a Listener**

A PC can be connected the same way as an RS232 type NMEA Listener.

- Connect the PRO-NBF-1 Listener A/+ to the Tx pin of the RS232 connector. (PIN 2)
- Connect the PRO-NBF-1 Listener B/- to the Ground pin of the RS232 connector. (PIN 5)

PAGE INTENTIONALLY LEFT BLANK

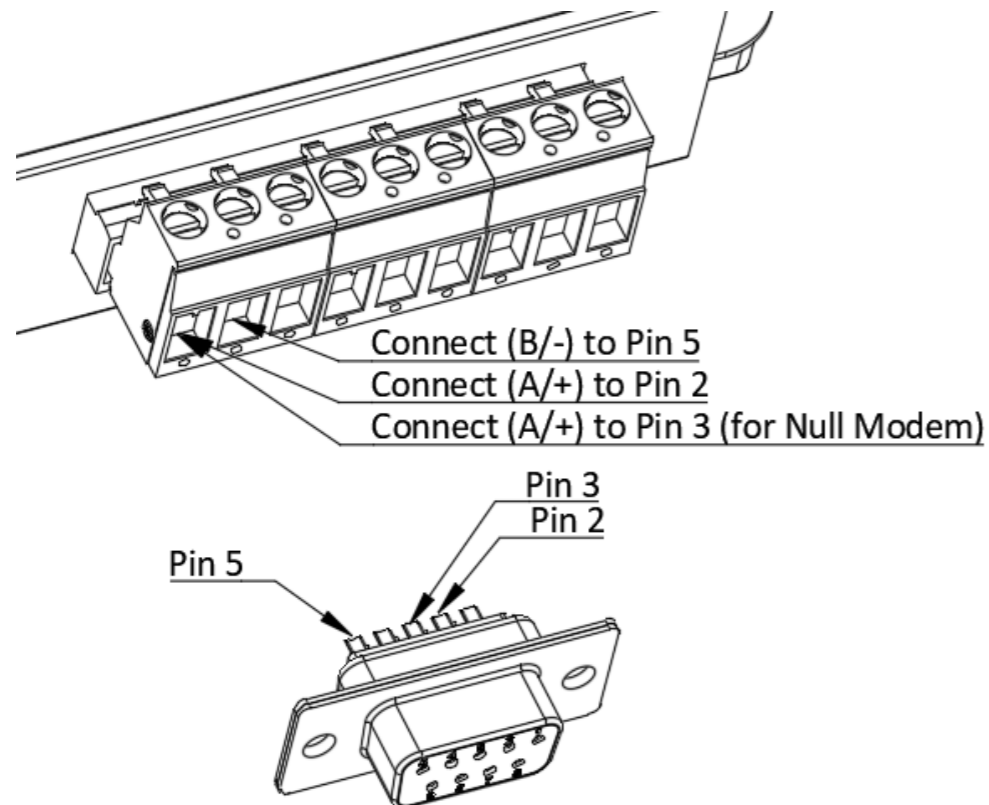

## Troubleshooting Guide

First level PRO-NBF-1 diagnostics / fault finding can be performed by observing the LED behavior. The normal behavior of the PRO-NBF-1 LEDs is described below. If the LEDs are not behaving as expected, this will indicate a fault in either the device connected to the PRO-NBF-1, the wiring/connections, or the PRO-NBF-1 itself.

Name of LED and it's behaviour	If LED does not light
<b>Power (Blue 'PWR') LED</b>  Solid blue to indicate presence of power.	<ul style="list-style-type: none"> <li>• Ensure that the power terminal plug is correctly located and seated.</li> <li>• Ensure that the wires are securely connected to the plug.</li> <li>• Ensure that positive power and ground wires have been connected with the correct polarity.</li> <li>• Ensure that any external power fuse has not blown and that the external power isolation switch is closed.</li> <li>• Ensure that the power supply meets the Voltage and Current requirements as defined in the Specifications</li> </ul>
<b>Listener (Green 'IN') LEDs</b>  Flashes on receipt of any data	<ul style="list-style-type: none"> <li>• Ensure that the PRO-NBF-1 has power, refer to "Power (Blue 'PWR') LED" above.</li> <li>• Ensure that the (NMEA Talker) device connected to this input is powered and is configured to output data.</li> <li>• Ensure that the plug is correctly located and the wires are securely connected to the plug, with the correct polarity.</li> <li>• Ensure that two data wires are connected to the PRO-NBF-1 Listener terminals. If the (NMEA Talker) device does not have a 'negative' data connection/wire, connect its ground to the 'B/-' on the PRO-NBF-1 Listener terminal instead.</li> </ul>
<b>Talker (Amber 'OUT') LEDs</b>  Flashes on transmit of data	<ul style="list-style-type: none"> <li>• Ensure that the PRO-NBF-1 has power, refer to "Power (Blue 'PWR') LED" above.</li> <li>• Ensure that the plug is correctly located and the wires are securely connected to the plug, with the correct polarity.</li> <li>• Ensure that the corresponding Green (Data IN) LED is lit to indicate that data is being sent to the PRO-NBF-1.</li> <li>• For PC Connections, Actisense NMEA Reader can be used to determine if there is any data on the output.</li> </ul>

## Technical Support and the Returns Procedure

All installation instructions and any warnings contained in this manual must be followed before contacting Actisense technical support. If the troubleshooting guide did not help resolve the problem and an error persists, please contact Actisense Technical Support to help trace the issue before considering the return of the product. If the Actisense support engineer concludes that the PRO-NBF-1 unit should be returned to Actisense, a 'Return Merchandise Authorisation' (RMA) number will be issued by the support engineer.

**The RMA number must be clearly visible on both the external packaging and any documentation returned with the product. Any returns sent without an RMA Number will incur a delay in being processed and a possible charge. Any cables originally supplied with the product are to be included in the returned box.**

## Technical Specification

Power Supply	
Input Supply Voltage	9 to 35V DC
Input Supply Current	150mA max @ 12V DC (all outputs @ full drive into 100Ω loads)
Input Protection	Continuous reverse polarity and ESD protection
Power Indicator	LED, Blue - Indicates unit is functioning correctly
Input Supply Connector	Pluggable 2 way screw terminal, 5.08mm pitch (12 to 30 AWG)
NMEA 0183 Port - Listener & Talkers	
Number of Listener / Input Ports	One isolated NMEA 0183 Listener
Number of Talker / Output Ports	Six isolated NMEA 0183 Talkers
Compatibility	Fully NMEA 0183, RS422 & RS232 compatible. RS485 Listener compatible
Speed / baud rate	4800 to 115200 bps
Talker Output Voltage drive	>= 2.2V (differential) into 100Ω
Talker Output Current drive	20mA max.
Talker Output Protection	Short circuit and ESD
Talker Data Indicator	LED, Orange (Flashes at data rate)
Listener Input Voltage Tolerance	-15V to +15V continuous, -35V to +35V short term (<1 second)
Listener Input Protection	Current limited, overdrive protection to 40V DC and ESD protection
Listener Data Indicator	LED, green (Flashes to indicate valid input)
Connectors	Pluggable 2/3-way screw terminals, 5.08mm pitch (12 to 30 AWG)
Isolation	
NMEA 0183 Listener	OPTO-Isolated, Hi-Pot tested to 1000V
NMEA 0183 Talker	Uses IsoDrive™, Hi-Pot tested to 1000V
Mechanical	
Housing Material	316 Stainless Steel
Dimensions	139mm (L) x 128mm (W) x 27mm (H)
Weight	335g
Mounting	Bulkhead mount or DIN rail mount (DIN kit 1)
Approvals and Certifications	
EMC	IEC 60945:2002-08, DNVGL-CG-0339:2019 & IACS UR E10 Rev7
Compass safe distance	600mm
Type Approval Certificate	RINA
Operating Temperature	-25 to +70°C
Storage Temperature	-40 to +85°C
Maximum Relative Humidity (RH)	95% @ 55°C
Environmental Protection	IP40
Guarantee	5 Years

All specifications are taken with reference to an ambient temperature of 25°C unless otherwise specified. All specifications correct at time of print.



Part Number	Description
PRO-NBF-1	1 OPTO input, 6 ISO-Drive outputs professional Type Approved Buffer
	<b>Accessory Description</b>
DIN-KIT-1	Kit of 2 clips & 4 screws. Use with top hat (EN 50 022) or G section (EN 50 035) rails
A-CONPACK-PNBF1	Pluggable Screwless Terminal pack for PRO-NBF-1
SRB-90	Kit of 2 x 90mm Stainless Steel Strain Relief Brackets
USBKIT-PRO	USB To Serial Adapter for use with PRO range products

## Product Dimensions:

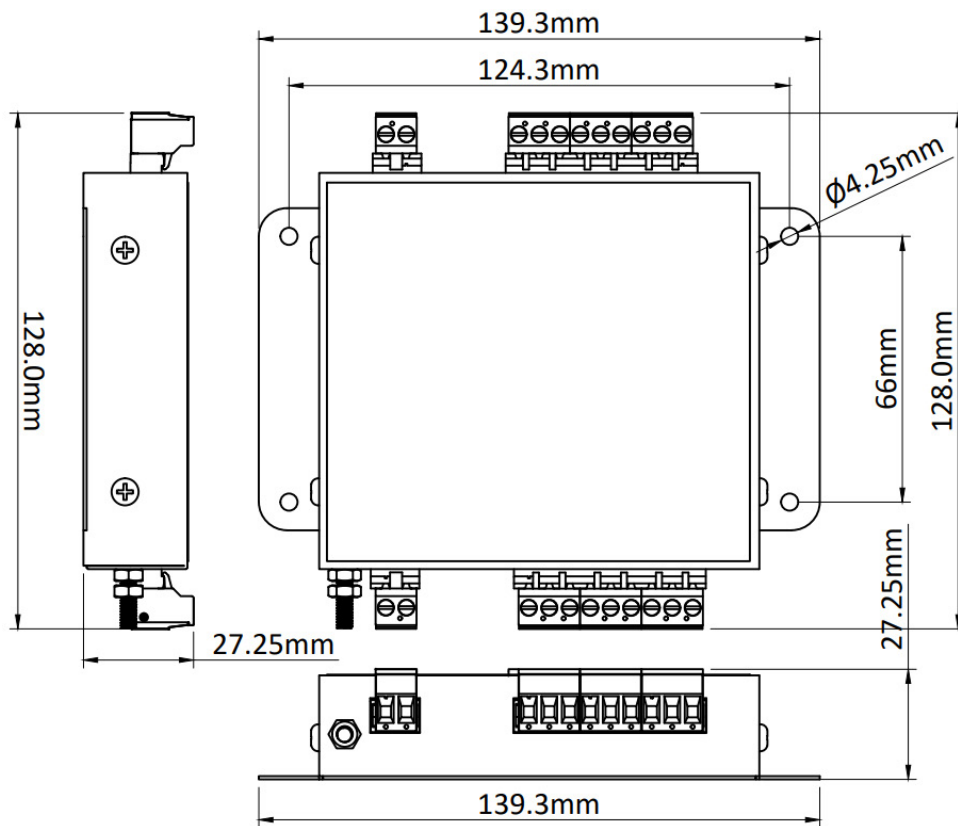

Active Research Ltd  
 21 Harwell Road  
 Poole, Dorset  
 UK, BH17 0GE  
 Telephone: +44 (0)1202 746682  
 Email: sales@actisense.com  
 Web: www.actisense.com

