



CKM Series 12-Button Customizable Keypad



User's Manual

Revision 1.0

Copyright ©2020 Carling Technologies, Inc.

60 Johnson Ave.
Plainville, CT 06062 USA
All Rights Reserved

<http://www.maretron.com>

Table of Contents

INTRODUCTION	1
FEATURES.....	1
THEORY OF OPERATION	2
<i>Figure 1 - Key Numbering.....</i>	<i>2</i>
HARDWARE DESCRIPTION	2
<i>Figure 2 - Hardware Description Front View.....</i>	<i>2</i>
<i>Figure 3 - Hardware Description Side View.....</i>	<i>3</i>
<i>Figure 4 - Hardware Description Back View.....</i>	<i>3</i>
<i>Figure 5 - CKM to NMEA 2000® Adapter Cable (A3703).....</i>	<i>4</i>
ORDERING OPTIONS	4
<i>Table 1 – Ordering Options</i>	<i>4</i>
INSTALLATION	5
UNPACKING THE BOX	5
CHOOSING INSTALLATION LOCATION	5
MOUNTING THE CKM12.....	5
<i>Figure 6 - Mounting Panel Cutout Dimension.....</i>	<i>6</i>
CONNECTING THE CKM12.....	6
CONNECTOR PIN DESCRIPTION	6
<i>Table 3 – 6 Position Connector Pin Description.....</i>	<i>6</i>
NMEA 2000® CONNECTION	7
<i>Figure 7 - NMEA 2000 Connectors</i>	<i>7</i>
CONFIGURING THE CKM12	8
GENERAL TAB	8
<i>Figure 8 – General Tab Dialog Box.....</i>	<i>8</i>
Instance	9
Key #n	9
Data Instance and Indicator.....	9
ADVANCED TAB.....	9
<i>Figure 9 – Advanced Tab Dialog Box.....</i>	<i>9</i>
MAINTENANCE	10
TROUBLESHOOTING	10
<i>Table 5 - Troubleshooting Symptoms and Check Procedure.....</i>	<i>10</i>
TECHNICAL SPECIFICATIONS	11
CERTIFICATIONS	11
NMEA 2000® PARAMETER GROUP NUMBERS (PGNs)	11
ELECTRICAL.....	11
MECHANICAL.....	11
ENVIRONMENTAL OPERATION	12
ENVIRONMENTAL TESTING	12
TECHNICAL SUPPORT	13
<i>Figure 10 - Technical Support QR Code.....</i>	<i>13</i>
MARETRON (2 YEAR) LIMITED WARRANTY	13
WARRANTY RETURN PROCEDURE:.....	14
APPENDIX A – NMEA 2000® INTERFACING.....	14

CKM12 NMEA 2000® PERIODIC DATA TRANSMITTED PGNS 15
PGN 127501 – BINARY STATUS REPORT 15



WARNING

- Opening the CKM12 device voids warranties set forth by Carling Technologies.
- Please ensure that you read and understand this manual before installation and use.
- The CKM12 must be installed in accordance with standards set forth by ABYC and other applicable agencies.

Introduction

Congratulations on your purchase of the Maretron CKM12 12 Button Customizable Keypad. Carling Technologies has proudly designed and built your CKM12 to the highest standards for reliability and accurate service.

The CKM12 is a sealed, IP69K front rated, customizable keypad ready to deliver years of dependable operation within the harsh demands of the marine environment. The CKM12 features 12 keys and a rubberized coating over the keypad. The CKM12 reduces installation time and the complexity and cost of traditional wiring harnesses by utilizing NMEA 2000® CAN interface technology.

The CKM12 connects directly to an NMEA 2000® network through the use of a CKM to NMEA 2000® Adapter Cable. Configure the CKM12 by using a Maretron USB100 or IPG100 tethering the NMEA2000® network to a PC running N2KAnalyzer. Control MPower and other Maretron systems with the CKM12 through an NMEA 2000® Network. Using standard NMEA 2000® messaging, the CKM12 can illuminate any of its 12 blue LED lights for status of circuit state.

The CKM12 is available in 2 standard configurations. Custom configurations are available with a minimum order quantity of 100 pieces.

Please carefully read and follow these instructions for installation, configuration, and usage of the Maretron CKM12 module to ensure optimal performance.

Features

- Key Detent Provides Tactile feel when pressing
- Configurable Operation and Appearance Aspect
- All Key Positions have Blue LED's
- Horizontal or Vertical Mounting Options
- Screwless, Snap-In Mounting
- IP69 Rated (front) IP68 (rear) with Plug for Unused Connector
- NMEA 2000 CAN Protocol
- LED Feedback of Controlled Circuit State
- Low Current Consumption (Max Current 100mA)
- NMEA 2000 LEN: 2
- Operating Voltage: 8 - 32 VDC
- Endurance Tested to Reach Minimum of 1,000,000 Operations

For Technical Specifications please refer to page 11

Theory of Operation

Key position will be reported via the NMEA2000® Standard 127501 “Binary Status Report” CAN message. Each button is considered a separate binary (on or off) switch and will be numbered as follows:



Figure 1 - Key Numbering

There is a total of twelve blue LEDs, each configurable via CAN message to act as a function indicator. The LEDs are located above the top row of keys and below the bottom row of keys. The icons on each key are lit by an LED backlight located behind the icon. LEDs can be tied to a channel of any device on the CAN network that reports the NMEA2000® standard 127501 “Binary Status Report” message. When the associated channel reports it is in the “on” state, the LED will be turned on and set to the function indicator brightness level. When the associated channel reports it is in the “off” state, the LED would be extinguished.

Hardware Description

UNIT: INCH [MM]

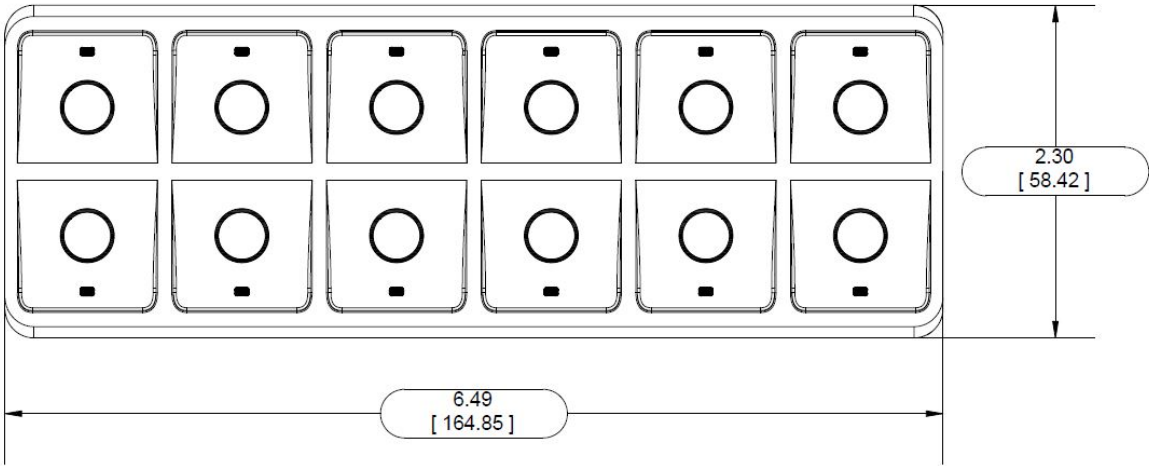

Figure 2 - Hardware Description Front View

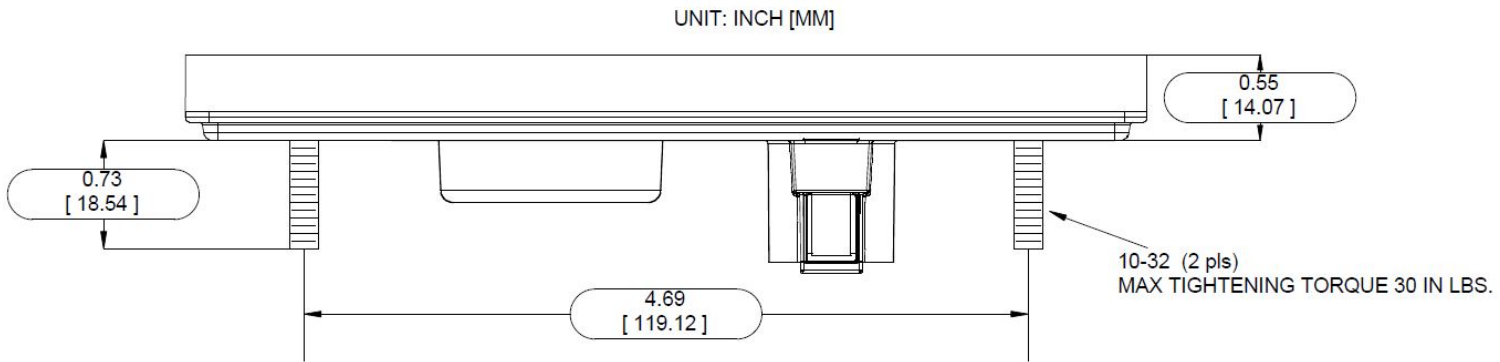

Figure 3 - Hardware Description Side View

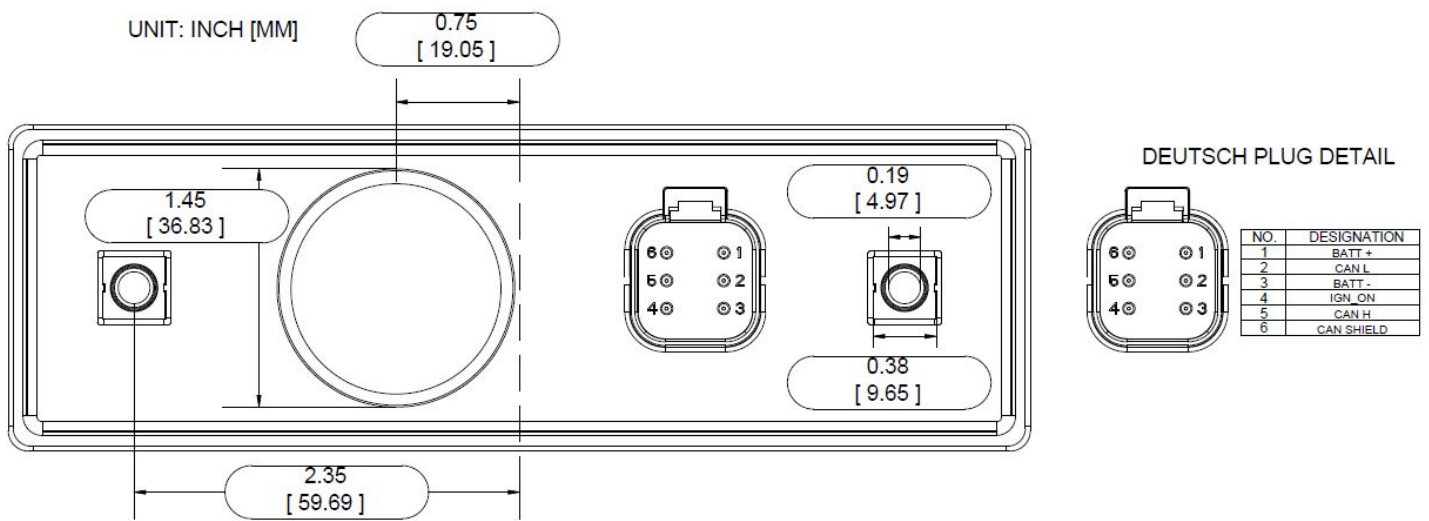

Figure 4 - Hardware Description Back View

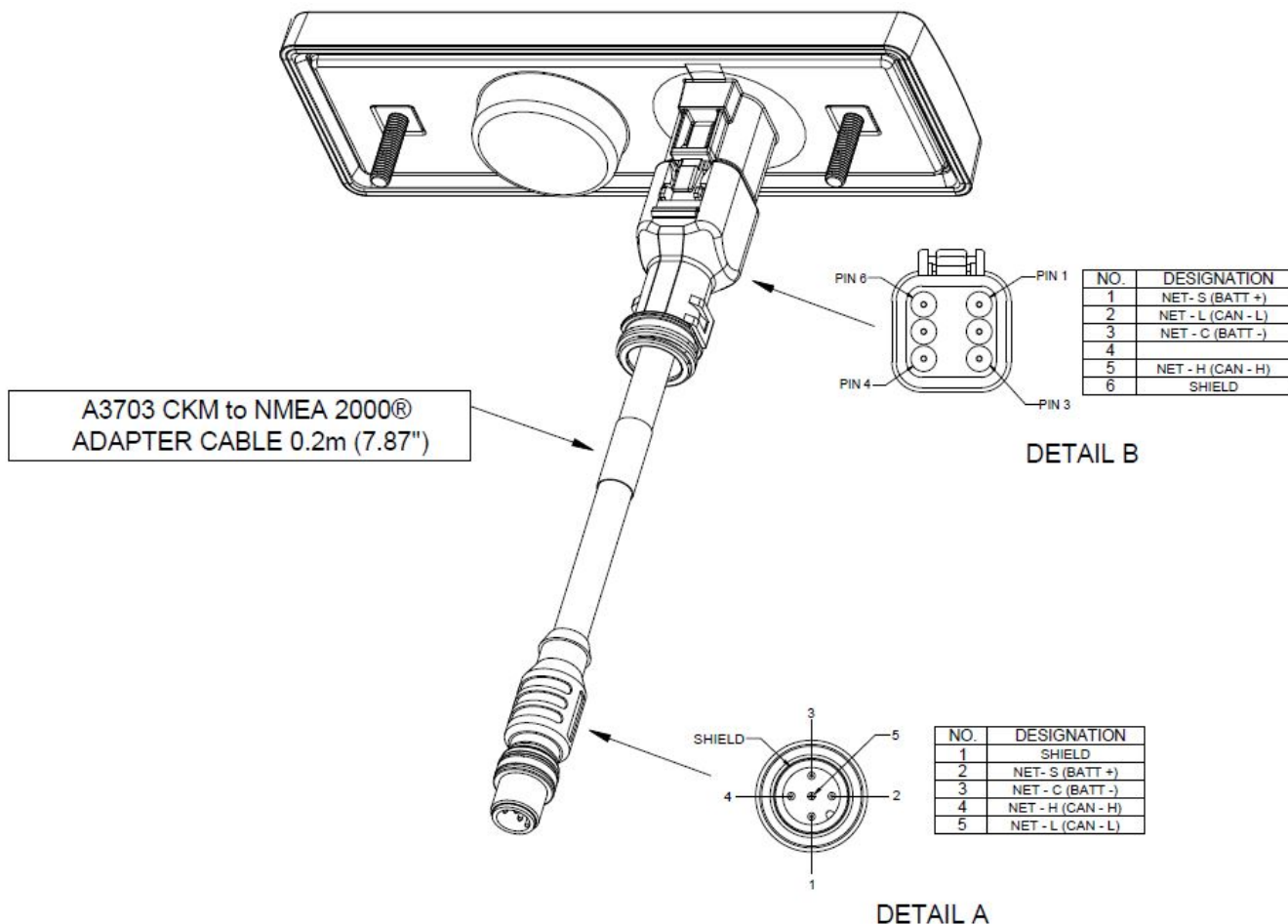

Figure 5 - CKM to NMEA 2000® Adapter Cable (A3703)

Ordering Options

The CKM12 can be ordered as outlined in *Table 1*.
 Custom Configurations are available with a minimum order of 100 units.
 Contact Marine.Sales@carlingtech.com for custom quotation.

Table 1 – Ordering Options

PART NUMBER	DESCRIPTION
A3802-1	CKM12 Keypad (Circle on Buttons) with CKM to NMEA 2000® Adapter Cable .2m (A3703) (Horizontal or Vertical Installation)
A3802-2	CKM12 Keypad (Number in Center of Circle on Buttons) with CKM to NMEA 2000® Adapter Cable .2m (A3703) (Horizontal Installation)
A3703	CKM to NMEA 2000® Adapter Cable - .2M

Installation

Installing the Maretron CKM12 involves the following steps.

Unpacking the Box

When unpacking the box containing the Maretron CKM12, you should find the following items:

- 1 – CKM12 – 12 Button Keypad
- 1 – CKM12 User's Manual on USB flash drive
- 1 – CKM12 Panel Installation Template
- 1 – Warranty Registration Card
- 1 – A3703 CKM to NMEA 2000® Adapter Cable
- 2 – 10-32 Nuts (Mounting Hardware)

If any of these items are missing or damaged, please contact Maretron Technical Support (please refer to page 13 for contact information).

Choosing Installation Location

Please consider the following when choosing a mounting location.

- The CKM12 is waterproof, so it can be installed in a damp or dry location.
- Consider mounting depth (5" recommended clearance needed for proper cable bend radius)
- The CKM12 is temperature-rated to 85°C (185°F). Mount CKM12 away from engines or engine rooms where the operating temperature exceeds the specified limit.
- After mounting, ensure cable strain relief.

Mounting the CKM12

Locate the panel mounting template supplied with the CKM12. After cutting panel mounting holes. Place the CKM12 into panel cutout. The CKM12 mounting studs will protrude to the backside of the panel hole. The use of silicone sealant is acceptable to provide extra sealing protection of the CKM12 to the mounting panel. Thread supplied 10-32 nuts onto these threaded studs. Tighten to 30 In. lbs. Do not use permanent adhesive to install unit. Certain adhesives such as methacrylate will cause cracking of the plastic enclosure. The use of permanent adhesive for installation will void warranty of CKM12 unit. For reference to the needed panel cutout dimensions see *Figure 5*.

UNIT: INCH [MM]

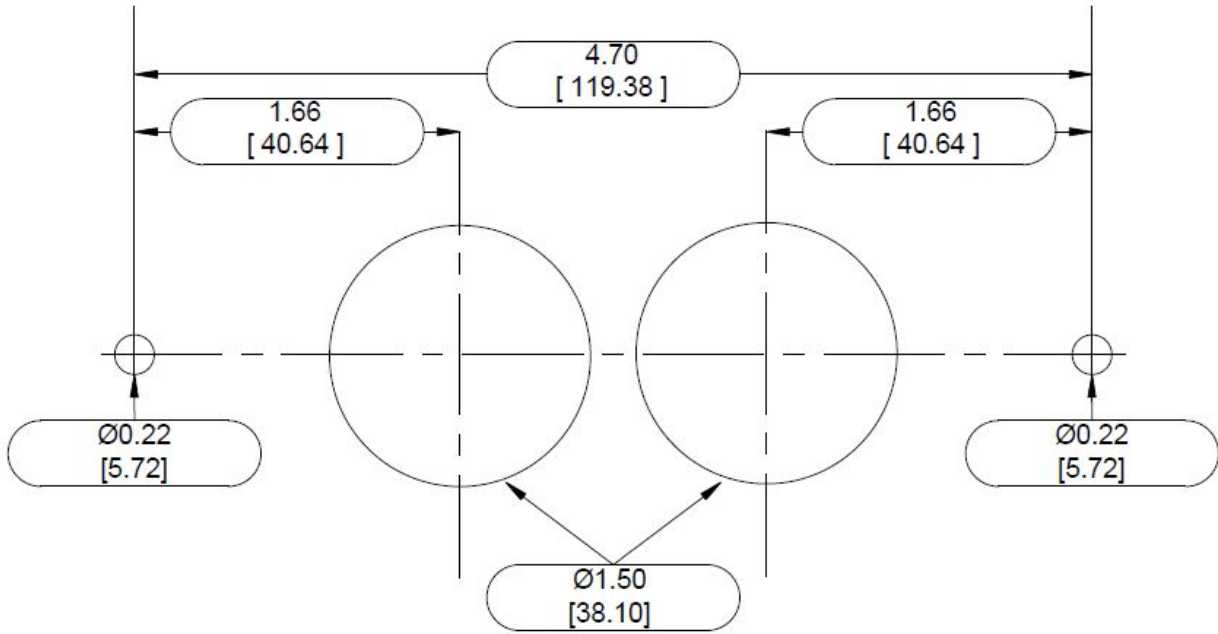

PANEL THICKNESS MIN: 0.05 [1.27] MAX: 0.30 [7.62]

Figure 6 - Mounting Panel Cutout Dimension

Connecting the CKM12

Connecting the CKM12 consists of plugging the unit to the vessel’s NMEA 2000® network. The unit can be connected to NMEA 2000 network directly to the 6 position Deutsch DT Series receptacle molded into the unit or via use of the A3703 CKM to NMEA 2000® Adapter Cable.

Connector Pin Description

Table 2 – 6 Position Connector Pin Description

Connector Pin No. (Location)	Description
1	NET_S (Batt. +)
2	NET_L (CAN_L)
3	NET_C (Batt. -)
4	Unused
5	NET_H (CAN_H)
6	Shield

NMEA 2000® Connection

The NMEA 2000® connector is the round five-pin male connector found on the VMM to NMEA 2000® Adapter Cable. This connector is known as a DeviceNet micro connector. You connect the VMM6 to a NMEA 2000® network using a Maretron NMEA 2000® cable (or compatible cable) by connecting the female end of the cable to the male NMEA 2000 connector VMM to NMEA 2000® Adapter Cable. (note the key on the male connector and keyway on the female connector). Be sure the cable is connected securely and that the collar on the cable connector is tightened firmly. Connect the other end of the cable by plugging into the 6 position connector on the rear of the CKM12, applying pressure until the connector latch clicks. The CKM12 is designed so that you can plug or unplug it from an NMEA 2000® network while the power to the network is connected or disconnected. Please follow recommended practices for installing NMEA 2000® network products.

NMEA 2000 connections can be made using pre-assembled leads or may be made using field attachable connectors and cables (See: *Figure 7*).

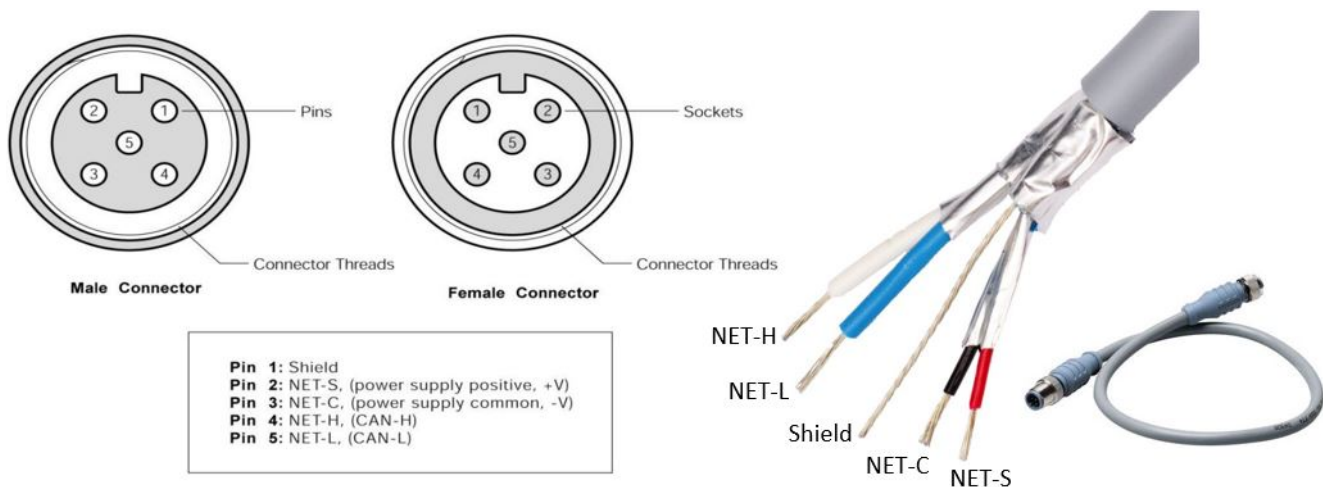

Figure 7 - NMEA 2000 Connectors

Please refer the Maretron website (www.maretron.com/products/cabling.php) for relevant products.

Configuring the CKM12

The CKM12 transmits data over an NMEA 2000® network as it is shipped from the factory. The default device instance is “Instance 50”. The default data instance whose state is reflected by the LED’s on the CKM12 is “Instance 32”. The unit will pair with Maretron CLMD12 and CLMD16 to toggle each unit’s first 12 ECB’s ON and OFF. If more than one CLMD12, CLMD16 or one of each unit is on the same NMEA 2000® network the CKM12 unit will have to be configured. Depending on desired switch control, default configuration may not work for your application and custom configuration will be needed. The CKM12 is configured using Maretron N2KAnalyzer®. The following describe the configurable parameters of the CKM12.

General Tab

The screenshot shows a configuration dialog box with two tabs: "General" (selected) and "Advanced". At the top, there is an "Instance:" label followed by an empty text input field. Below this are five rows, each representing a key's LED configuration. Each row has a label "Key #X LED" on the left, a "Data Instance:" label followed by a spin box, and an "Indicator:" label followed by a spin box. The spin boxes for "Data Instance" are set to 40, and the spin boxes for "Indicator" are set to 1, 2, 3, 4, and 5 respectively. At the bottom of the dialog, there are six buttons: "Load Config From File...", "Save Config To File...", "Restore Factory Defaults", "Get Config From Device", "Put Config To Device", and "Close". Below the buttons, a red text note reads: "RED text indicates a changed parameter that has not yet been put to the device".

Figure 8 – General Tab Dialog Box

CKM12 User's Manual

Instance

When connected to a NMEA 2000® network, this read-only field will indicate the indicator bank instance value that will be transmitted with the switch status in the 127501 Binary Status Report status message. To change the value of this field, change the value of the CKM12 device instance, as shown in Advanced Tab.

Key #n

The CKM12 has 12 Keys, each with a separate indicator output number referencing each key number as depicted in *Figure 1 - Key Numbering* on page 2.

Data Instance and Indicator

This Data Instance and Indicator will be the instance information in which the VMM6 will be tethered to via PGN.

The LED for the corresponding switch will be lit or flashing whenever the Indicator that corresponds to the selected Data Instance is transmitting an On or fault state on the network. The LED on the key will be dark otherwise.

Advanced Tab

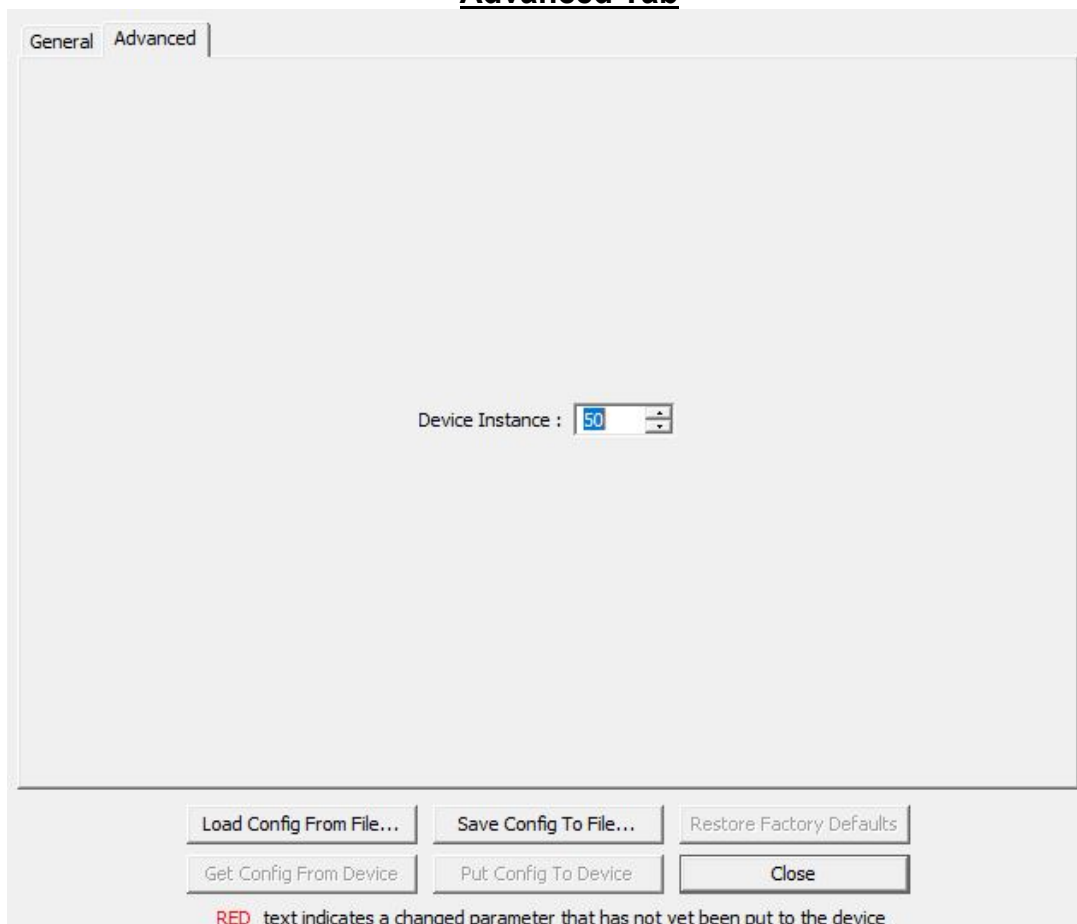

Figure 9 – Advanced Tab Dialog Box

This tab contains the Device Instance setting; If there are multiple instances of this device on a network each would be set to a separate instance.

Maintenance

Regular maintenance is important to ensure continued proper operation of the Maretron CKM12. Perform the following tasks periodically:

- Clean the unit with a soft cloth and mild soapy water. Do not use chemical cleaners as they may remove paint and markings or may corrode the CLMD16 enclosure or seals. Do not use any astringent cleaners such as acetone, MEK, Alcohol, Etc. These cleaners will deteriorate the CKM12 unit.
- Ensure that the unit is mounted securely and cannot be moved relative to the mounting surface.
- Check the security of the cable connected to the NMEA 2000® connector and tighten if necessary.

Troubleshooting

If you notice unexpected operation of the Maretron CKM12, follow the troubleshooting procedures in this section to remedy simple problems. If these steps do not solve your problem, please contact Maretron Technical Support. Refer to page 13 for contact information.

Table 3 - Troubleshooting Symptoms and Check Procedure

Symptom	Troubleshooting Procedure
CKM12 Module Un-Responsive	<ul style="list-style-type: none"> • Check Connections to CKM to NMEA 2000® Adapter Cable. • Using a Maretron USB100 or Maretron IPG100, connect to the NMEA 2000® network and ensure device is configured.
Any other problems	<ul style="list-style-type: none"> • Please refer to the CKM12 product page on the Maretron website for additional troubleshooting suggestions.

Technical Specifications

As Carling is constantly improving its products, all specifications are subject to change without notice.

Certifications

Parameter	Comment
NMEA 2000® Standard	Certified
CE Mark	Recreational Craft Directive 2014/35/EU

NMEA 2000® Parameter Group Numbers (PGNs)

Description	PGN #	PGN Name	Default Rate
Periodic Data PGNs	127501	Binary Status Report	1 time / 15 seconds and on switch change
Response to Requested PGNs	126464	PGN List (Transmit and Receive)	N/A
	126996	Product Information	N/A
	126998	Configuration Information	N/A
	065300	Proprietary	N/A
Protocol PGNs	059392	ISO Acknowledge	N/A
	059904	ISO Request	N/A
	060928	ISO Address Claim	N/A
	065240	ISO Address Command	N/A
	126208	NMEA Request/Command/Acknowledge	N/A
	126993	Heartbeat	1 time / 60 seconds

Electrical

Parameter	Value	Comment
Operating Voltage	8 – 32 VDC	
Power Consumption	100 mA	NMEA 2000® Interface
Load Equivalence Number (LEN)	2	NMEA 2000® Spec. (1LEN = 50 mA)
Communication	CAN 2.0b	NMEA 2000® Interface
Programming	Proprietary	Via Maretron USB100 or IPG100
Insulation Resistance	ISO 16750-2	500VDC with a duration of 60s
Electrical Endurance	1,000,000 Operations	

Mechanical

Parameter	Value	Comment
Size	6.49" x 2.3" x 1.28" (164.84mm x 58.42mm x 32.51mm)	
Weight	0.35 lb. (0.158 kg)	
Material	Front Membrane – Silicone Housing - Acetal, UV stabilized	
Illumination	12- Independent LEDs	Located under each button
Dimming		
Connection	Deutsch DT-Series 6 pin receptacle	
Mounting	2- 10-32 Threaded Studs (Rear Mounted)	

Environmental Operation

Parameter	Value
Operating Temperature	-40°C to 85°C
Ingress Protection	IP69 (Front) IP68 (Rear)
Storage Temperature	-40°C to 85°C
Ignition Protection	Ignition Protected

Environmental Testing

Parameter	Standard	Conditions
High Temperature Soak	EN 60068-2-2:2007	96hrs. @ 85°C
Low Temperature Soak	EN 60068-2-1:2007	96 hrs. @ -40°C
Temperature Cycling (Operating)	IEC 60068-2-14:2009	-40°C - 85°C (2 cycles of 8 hrs.)
Temperature Shock (Storage)	IEC 60068-2-14:2009	T _{min} = -40°C, T _{max} = 85°C
Simulated Solar Radiation	EN 60068-2-5:2010 (Procedure B)	10 days @ 40°C
Ignition Protection	ISO 8846	
Humidity (Soak)	EN 60068-2-78:2002	RH = 93% +/-3%, Exposure 10 days
Humidity - Cyclic	EN 60068-2-30:2005	RH (> 90%), 6 cycles of 24hrs
Dust Ingress	IEC 60529:2001	Method EN60529 Section 13 Result IP6X
Water Ingress	DIN 40050-9:1993 IEC 60529:2001	Method as DIN 40050-9 Result IP69K
Mechanical Shock - Drop Test	EN 60068-2-31:1993	500mm free-fall, all faces of 3 axes
Mechanical - Shock	60068-2-27:2009	500m/s ² , pulse duration 11ms
Mechanical - Bump	60068-2-29:1993	400m/s ² 6ms shock pulses, 3 axes
Vibration (General)	60068-2-6: 1996	Sine shaped sweep 5 Hz to 500 Hz Amplitude, 5g, (20 Cycles in each plane)
Vibration (Random)	EN 60068-2-64:1995 (Method 1)	Random excitation at 10, 150, 220, and 350 Hz breakpoint frequencies, 5 hours in each axis
Vibration (Resonant Search)	60068-2-6: 1996	frequency range 10 Hz – 2 kHz @ 5G (5 Minutes at each resonant point)
Chemical Resistance	ISO 16750-5 (Method 2)	Test method = B
Salt Spray(Corrosion Resistance)	EN 60068-2-52: 1996	Chamber Temperature = 35°C (level 4 severity)
Component Test - Electrical Transients Immunity	ISO 11452-2:2004	100V/m, 20MHz to 2GHz
Component Test - Electrical Transients Emissions	ISO 13766:2006 Section 5 Annex D and Annex E	Distance of 1 m in the horizontal and vertical polarization, 30 MHz to 1 GHz
Component Test - Electrical Transients Conducted	ISO 7637-2:2004	Method as per ISO 7637-2-Annex A2
Electrostatic Discharge (ESD)	ISO 10605	+/- 8 kV (Direct), +/- 15 kV (Air)

Technical Support

If you require technical support for Maretron products, you can reach us in any of the following ways:

Telephone: 1-866-550-9100
Fax: 1-602-861-1777
E-mail: support@maretron.com
World Wide Web: <http://www.maretron.com>
Mail: Carling Technologies, Inc.
Attn: Maretron Technical Support
120 Intracoastal Pointe Dr.
Jupiter, FL 33477 USA



Figure 10 - Technical Support QR Code

Scan this QR code with your smartphone for full technical information and a copy of this installation manual.

Maretron (2 Year) Limited Warranty

Carling Technologies warrants the Maretron® CLMD16 to be free from defects in materials and workmanship for two (2) years from the date of original purchase. If within the applicable period any such products shall be proved to Carling's satisfaction to fail to meet the above limited warranty, such products shall be repaired or replaced at Carling's option. Purchaser's exclusive remedy and Carling's sole obligation hereunder, provided product is returned pursuant to the return requirements below, shall be limited to the repair or replacement, at Carling's option, of any product not meeting the above limited warranty and which is returned to Carling; or if Carling is unable to deliver a replacement that is free from defects in materials or workmanship, Purchaser's payment for such product will be refunded. Carling assumes no liability whatsoever for expenses of removing any defective product or part or for installing the repaired product or part or a replacement therefore or for any loss or damage to equipment in connection with which Maretron® products or parts shall be used. With respect to products not manufactured by Carling, Carling's warranty shall in all respects conform to and be limited to the warranty actually extended to Carling by its supplier. The foregoing warranties shall not apply with respect to products subjected to negligence, misuse, misapplication, accident, damages by circumstances beyond Carling's control, to improper installation, operation, maintenance, or storage, or to other than normal use or service.

THE FOREGOING WARRANTIES ARE EXPRESSLY IN LIEU OF AND EXCLUDES ALL OTHER EXPRESS OR IMPLIED WARRANTIES, INCLUDING BUT NOT LIMITED TO THE IMPLIED WARRANTIES OF MERCHANTABILITY AND OF FITNESS FOR A PARTICULAR PURPOSE.

Statements made by any person, including representatives of Carling, which are inconsistent or in conflict with the terms of this Limited Warranty, shall not be binding upon Carling unless reduced to writing and approved by an officer of Carling.

IN NO CASE WILL CARLING BE LIABLE FOR INCIDENTAL OR CONSEQUENTIAL DAMAGES, DAMAGES FOR LOSS OF USE, LOSS OF ANTICIPATED PROFITS OR SAVINGS, OR ANY OTHER LOSS INCURRED BECAUSE OF INTERRUPTION OF SERVICE. IN NO EVENT SHALL CARLING'S AGGREGATE LIABILITY EXCEED THE PURCHASE PRICE OF THE PRODUCT(S) INVOLVED. CARLING SHALL NOT BE SUBJECT TO ANY OTHER OBLIGATIONS OR LIABILITIES, WHETHER ARISING OUT OF BREACH OF CONTRACT OR WARRANTY, TORT (INCLUDING NEGLIGENCE), OR OTHER THEORIES OF LAW WITH RESPECT TO PRODUCTS SOLD OR SERVICES RENDERED BY CARLING, OR ANY UNDERTAKINGS, ACTS OR OMISSIONS RELATING THERETO.

Carling does not warrant that the functions contained in any software programs or products will meet purchaser's requirements or that the operation of the software programs or products will be uninterrupted or error free. Purchaser assumes responsibility for the selection of the software programs or products to achieve the intended results, and for the installation, use and results obtained from said programs or products. No specifications, samples, descriptions, or illustrations provided Carling to Purchaser, whether directly, in trade literature, brochures or other documentation shall be construed as warranties of any kind, and any failure to conform with such specifications, samples, descriptions, or illustrations shall not constitute any breach of Carling's limited warranty.

Warranty Return Procedure:

To apply for warranty claims, contact Carling Technologies or one of its Maretron dealers to describe the problem and determine the appropriate course of action. If a return is necessary, place the product in its original packaging together with proof of purchase and complete a Return Merchandise Authorization (RMA) on the following web page:

https://www.maretron.com/rma_request.php

You will be contacted by email with instructions on where to send the unit for repair / evaluation. You are responsible for all shipping and insurance charges. Carling will return the replaced or repaired product with all shipping and handling prepaid except for requests requiring expedited shipping (i.e., overnight shipments). Failure to follow this warranty return procedure could result in the product's warranty becoming null and void.

Carling reserves the right to modify or replace, at its sole discretion, without prior notification, the warranty listed above. To obtain a copy of the then current warranty policy for Maretron® products, please go to the following web page:

<http://www.maretron.com/company/warranty.php>

Appendix A – NMEA 2000® Interfacing

This appendix is intended to relate specific characteristics of the CKM12 to how they are communicated via NMEA 2000® messages in order to help ascertain whether the messaging implemented by the CKM12 is compatible with other NMEA 2000® products. It is not a complete description of the messages. If you require detailed information on the messages, please obtain a copy of the NMEA 2000® standard documents from the National Marine Electronics Association (www.nmea.org).

CKM12 NMEA 2000® Periodic Data Transmitted PGNs

PGN 127501 – Binary Status Report

The CKM12 uses this PGN to transmit the state of the 12 Keys.

Field 1: Indicator Bank Instance – This field identifies the particular indicator bank to which this PGN applies. Please refer to Configuring the CKM12 on page 8 for instructions on how to program the value of this field.

2: Indicator #1 – This field indicates the state of Key #1.

The state will be one of the following values:

- “OFF” – The button is not pressed
- “ON” – The button is pressed

3 to 13: indicates the state of the 12 keys, 2 to 12 respectively.