

TACO Marine® Grand Slam Mounts

# GS-850 & GS-950 Mounts

INSTALLATION INSTRUCTION GUIDE

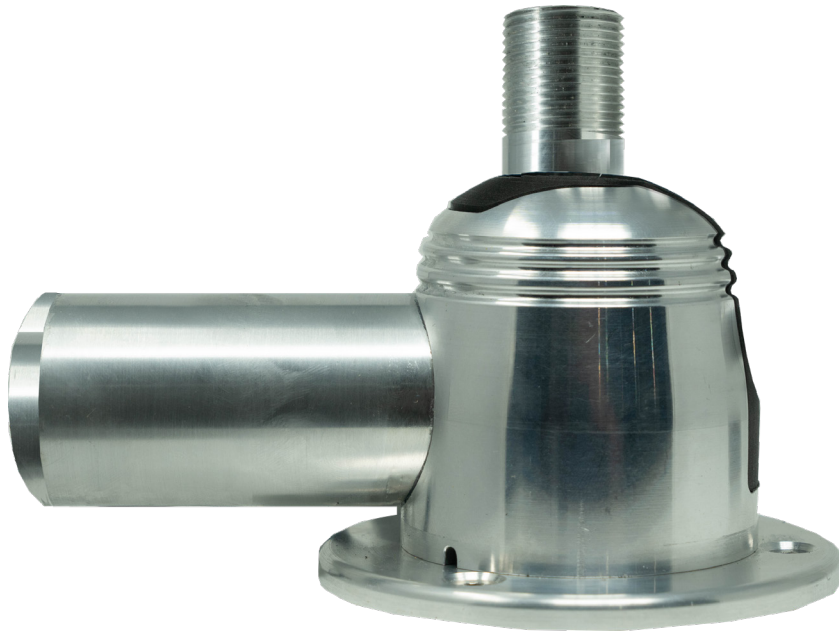

**⚠ WARNING:**

This product can expose you to chemicals including Lead, which is known to the State of California to cause cancer, birth defects or other reproductive harm. For more information go to [www.P65Warnings.ca.gov](http://www.P65Warnings.ca.gov).

**TACO**<sup>®</sup>  
MARINE

# Kit Contents

Required,  
but not included

**1** Grand Slam 850 mount  
(for both the GS-850 and GS-950)

**1** Drill template

**1** Tube, light and 6" lead for  
12-volt DC power supply for  
light function (GS-950 only)

- SAFETY GLASSES
- DRILL & SCREW GUN
- MASKING TAPE & PENCIL
- 1/4" DRILL BIT
- THREE 1/4-20 FLAT HEAD SCREWS  
**(LENGTH= (THICKNESS OF TOP) + 7/8")**
- THREE 1/4-20 LOCKING NUTS
- MARINE-GRADE SEALANT
- MARINE-GRADE GREASE / ANTI-SEIZE
- 3A FUSE IN THE MAIN +12 VDC POWER FEED
- GS-950 ONLY - 3A FUSE FOR LIGHT
- FLATHEAD SCREWDRIVER
- 18-GAUGE WIRE FOR GS-850 & GS-950
- TON-OFF-ON DPDT SWITCH UP/DOWN  
OPERATION 850 & GS-950
- THREE-POSITION SWITCH (OFF/ON/ON) FOR  
THE GS-950 ONLY

## TACO<sup>®</sup> Handy Tips

- Always use good quality stainless steel hardware when mounting the base.
- Please do not attempt to weld the base to anything.
- It is also important that your Canvas T-Top, Arch or Hardtop, be suitably constructed to provide a strong mounting surface area.

# 850/GS-950

**Thank you** for purchasing the Grand Slam 850 VHF Antenna Mount or Grand Slam 950 Masthead Anchor Light by TACO Marine. Since 1959, we have taken great pride in offering the highest-quality products with excellent customer service. We stand behind our products 100 percent. Please visit our website [tacomarine.com](http://tacomarine.com) for more detailed information on a wide variety of products and to register your new accessory for warranty.

## GS-850 MOUNT INSTALLATION FOR ANTENNA

1. Use the drill template to mark and drill with a 1/4" bit the three bolt holes.
2. If your top requires spacers, trim the included vinyl spacers to the depth of your hardtop thickness. Insert the vinyl spacers into each bolt hole.
3. Place a bead of marine-grade sealant on the underside of the mounting plate. This helps prevent water intrusion.
4. Securely bolt the base to the mounting surface. Be careful not to deform the top.
5. Connect wire according to Figures 1, 2 and 3 on page 6.
6. Use a 3A fuse in the main +12 VDC power feed.
7. Ensure the Black wire has a good connection to battery ground.
8. Operate the unit in both directions. The unit will automatically stop at full-up and lay-down positions.
  - Horizontal adjustment is possible to 80° angle. See diagram A.
  - The GS-850 features two set screws – one to lock the antenna positioning in place, the other for adjustment.

**NOTE: TACO recommends adjusting the angle slowly, every quarter turn. Over-adjusting could destroy the sensor, which voids the warranty.**

9. Connect wire antenna according to manufacturer's instructions.

- 
- The three (3) vinyl spacers will help prevent any hardtop compression. When installing through a hardtop, make sure the top is foam or core filled. It is recommended to use included spacers to fit inside where the mounting bolts pass through to ensure that when the bolts are tightened the top is not compressed.
  - Position the mount with the antenna or light attached so that it will not interfere with other hardware on the top.
  - Route electrical cables to boat's control panel and attach wires per manufacturer's recommendations.
  - Before installing VHF Antenna or LED Light Tube, apply a thin layer of marine grease or anti-sieze to the threaded shaft.

# GS-950 MOUNT INSTALLATION FOR MASTHEAD ANCHOR LIGHT

1. Use the drill template to mark and drill with a 1/4" bit the three bolt holes.
2. If your top requires spacers, trim the included vinyl spacers to the depth of your hardtop thickness. Insert the vinyl spacers into each bolt hole.
3. Place a bead of marine-grade sealant on the underside of the mounting plate. This helps prevent water intrusion.
4. Securely bolt the base to the mounting surface. Be careful not to deform the top.
5. Connect wire according to Figures 1, 2 and 3 on page 6.
6. Use a 3A fuse in the main +12 VDC power feed (not included).
7. Use a 3A fuse for the light (not included).
8. Ensure the Black wire has a good connection to battery ground.
9. Operate the unit in both directions. The unit will automatically stop at full-up and lay-down positions.
  - Horizontal adjustment is possible to 80° angle. See diagram A.
  - The GS-950 features two set screws – one to lock the light positioning in place, the other for adjustment.

**NOTE: TACO recommends adjusting the angle slowly, every quarter turn. Over-adjusting could destroy the sensor, which voids the warranty.**

10. Screw down the bottom of the light tube assembly to the mount.

**NOTE:** Before installing the LED Light Tube, apply a thin layer of marine grease or anti-sieze to the threaded shaft.

DIAGRAM A

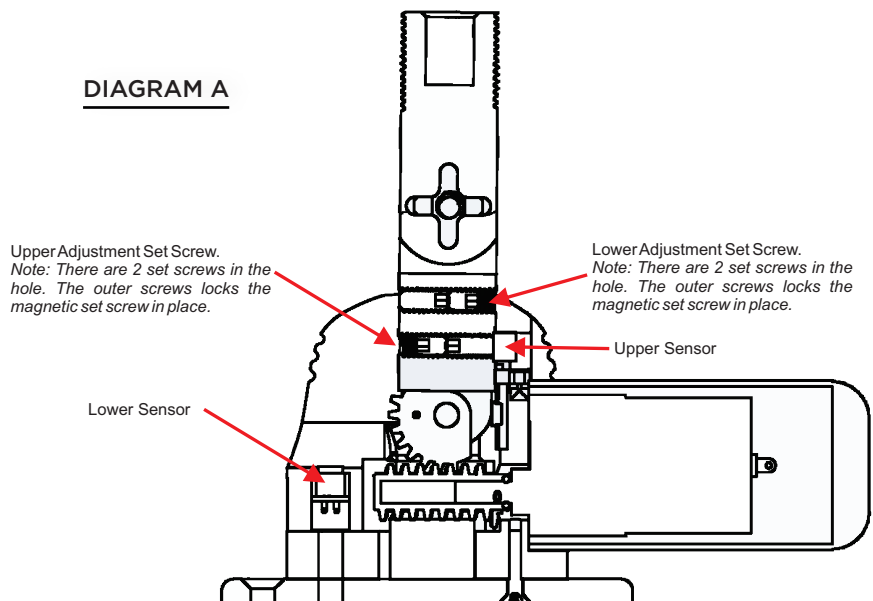

Adjustments to the arm position need to be done slowly 1/4 turn at a time. It is best practice to use an amp meter to determine when the sensor switch disables motor power. Failure to do this could result in motor failure.

## LIGHT

The light assembly is composed of two parts – one (1) Lamp Assembly and one (1) Stanchion.

1. Thread the LED light tube to the GS-850 mounting base.  
**Note:** Apply a thin layer of marine-grade grease or anti-seize to the threads before installing.
2. Noting the sticker that reads “TO BOW” on the light, position the light properly.
3. Attach your 18-Gauge, 3-wire cable coming from the helm to the 18-Gauge, 3-wire lead out of the GS-950 stanchion/tube assembly (refer to figure 4 on page 8).
4. Connect your chosen switch (not included) per manufacturer’s recommendations.
5. Mount the switch to your chosen location at the helm.

## EMERGENCY RELEASE OPERATION

Using a standard flathead screwdriver, remove the set screw **(A)** located on the side of the GS-850 and GS-950 base while holding the Antenna or Masthead Anchor Light shaft, being careful not to let the shaft fall. Once the screw is removed, gently lift up on the shaft and reposition the Antenna or Masthead Anchor Light. Once repositioning is complete, gently push back in the shaft until the screw holes are aligned and re-screw in the screw with the screwdriver, making sure not to over tighten and strip the threads. Repeat this process whenever manual override is necessary.

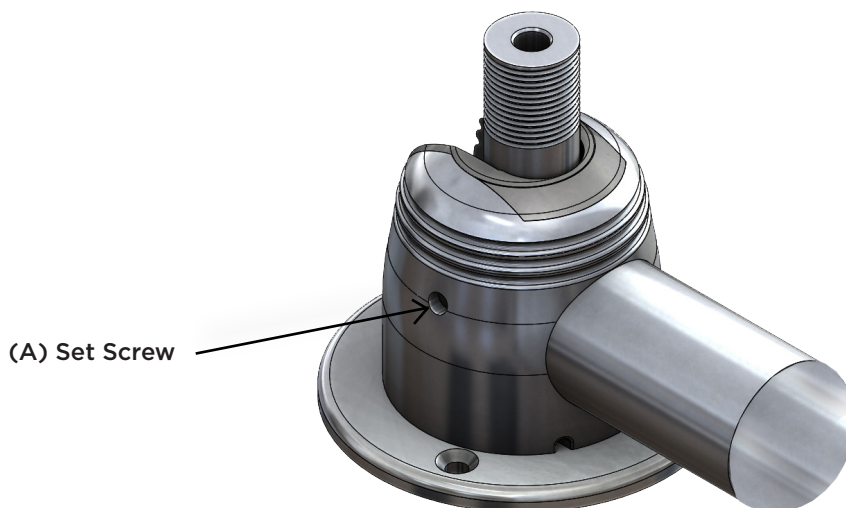

**NOTE:**

For instructions and to replace the Grand Slam 950 Masthead Anchor Light, purchase a replacement [F38-9000BLY] at [tacomarine.com](http://tacomarine.com).

# How to use

When boating with the Grand Slam 850 or Grand Slam 950, easily adjust the top-mounted VHF Antennas or Masthead Anchor Light with the simple push of a button. Once either accessory is mounted to the top and wired into the control panel, lift or descend the accessories by pressing the up or down buttons. When either accessory has reached its full upright or down position, the motor will stop automatically.

# How to clean

Always use a mild, non-abrasive soap and lots of fresh water. Thoroughly wash the aluminum with a soft towel or sponge utilizing lots of soap and water to remove all dried salt crystals and other contaminants. Rinse completely with direct water pressure.

## Safe Cleaners

**Mild dish washing liquid, specialty marine cleaners:**

Sea Safe Boat Wash, Boat Wash Concentrate and Super Suds.

**Safe marine lubricants:**

CRC Corrosion Inhibitor, Corrosion Block and Get Some Extreme.

## Harmful Cleaners

**Bleach (Clorox, etc.) and mild abrasive cleaners:**

Ajax, Comet, Soft Scrub, Rubbing Compounds, etc.

**Strong cleaners:**

409, Engine Degreasers, etc.

**Acids of any type:**

Such as Muriatic, naval jelly or aluminum acid.

# WIRING DIAGRAMS

WIRING SWITCH SCHEMATIC WITH BLUETOOTH CONTROLLER (FIGURE 1)

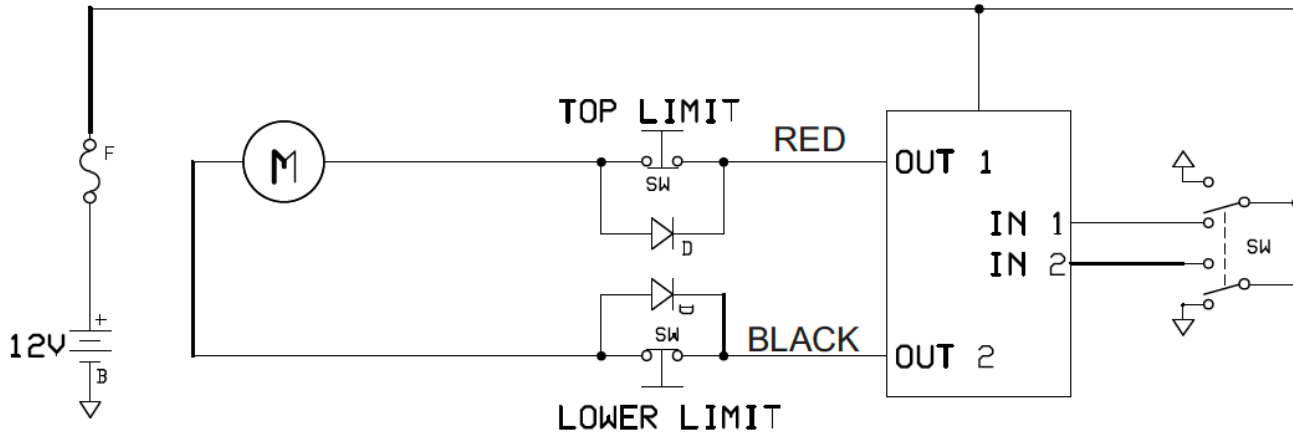

WIRING SWITCH SCHEMATIC W/O BLUETOOTH CONTROLLER (FIGURE 2)

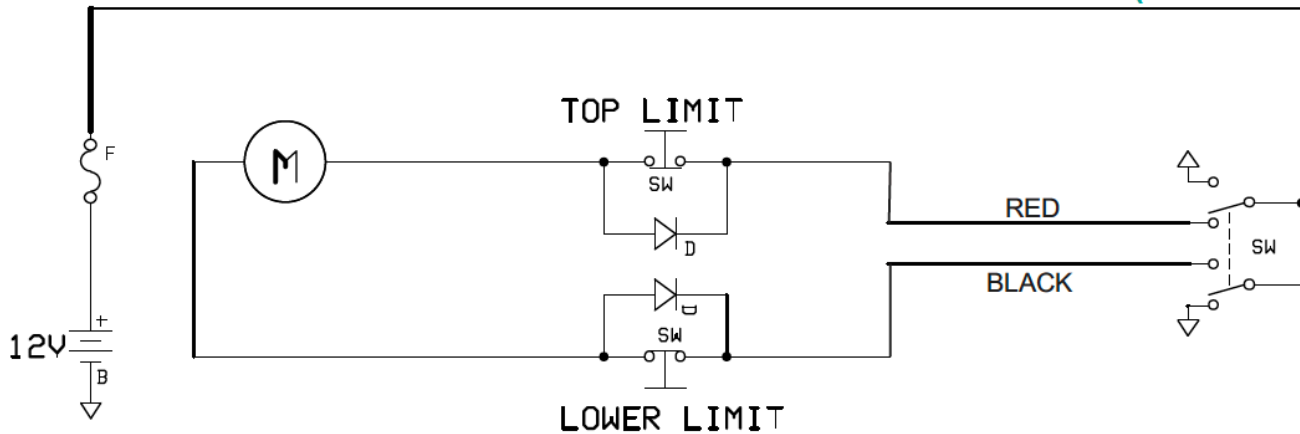

SWITCH CONNECTION (FIGURE 3)

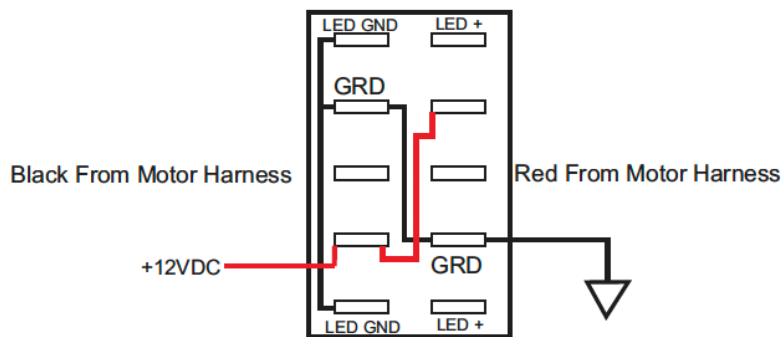

# WIRING DIAGRAMS

## MASTHEAD ANCHOR LIGHT (FIGURE 4)

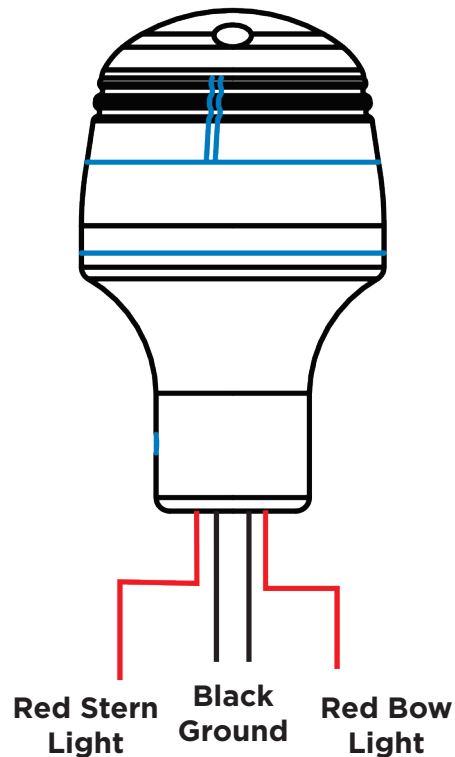
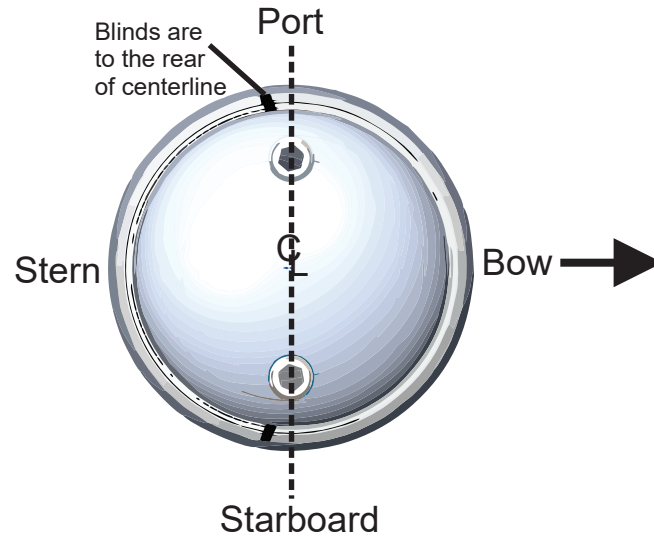



# PRODUCT DIMENSIONS

GS-850  
UP POSITION

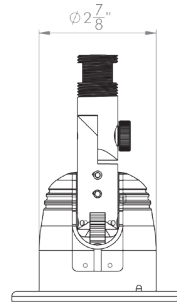
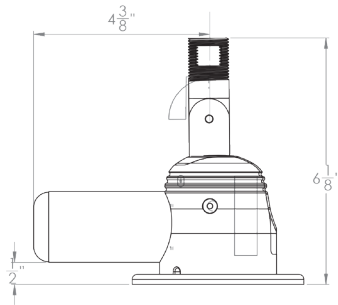

GS-850  
DOWN POSITION

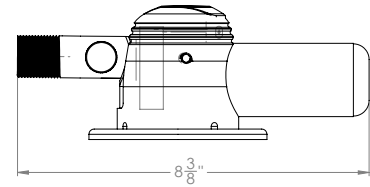
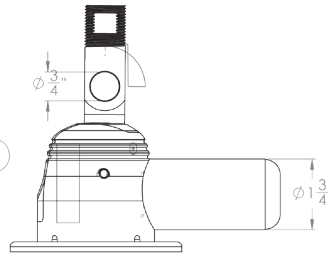
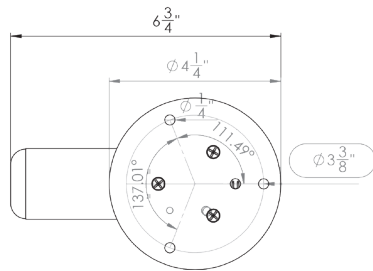
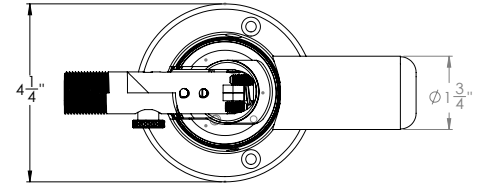

GS-950  
UP POSITION

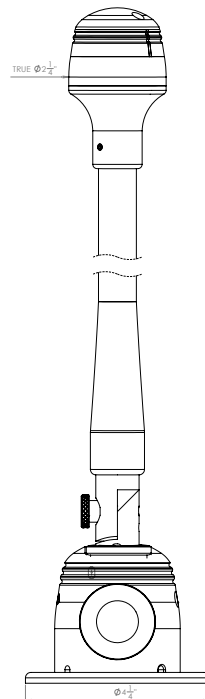
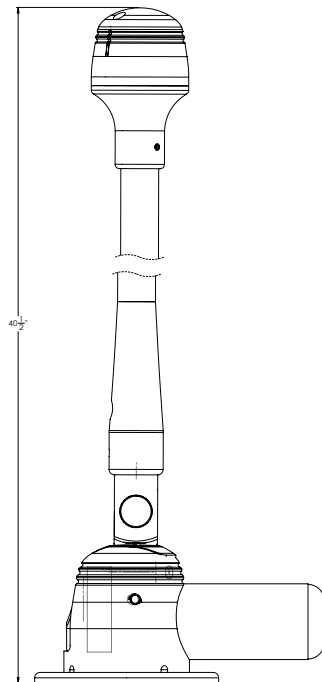

GS-950  
DOWN POSITION

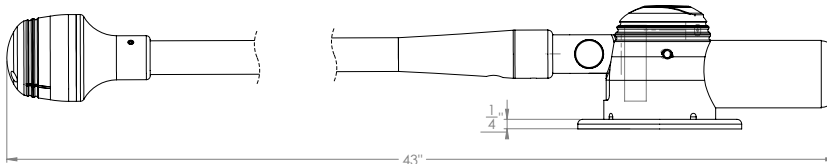

# GS-850/GS-950 Drill Template

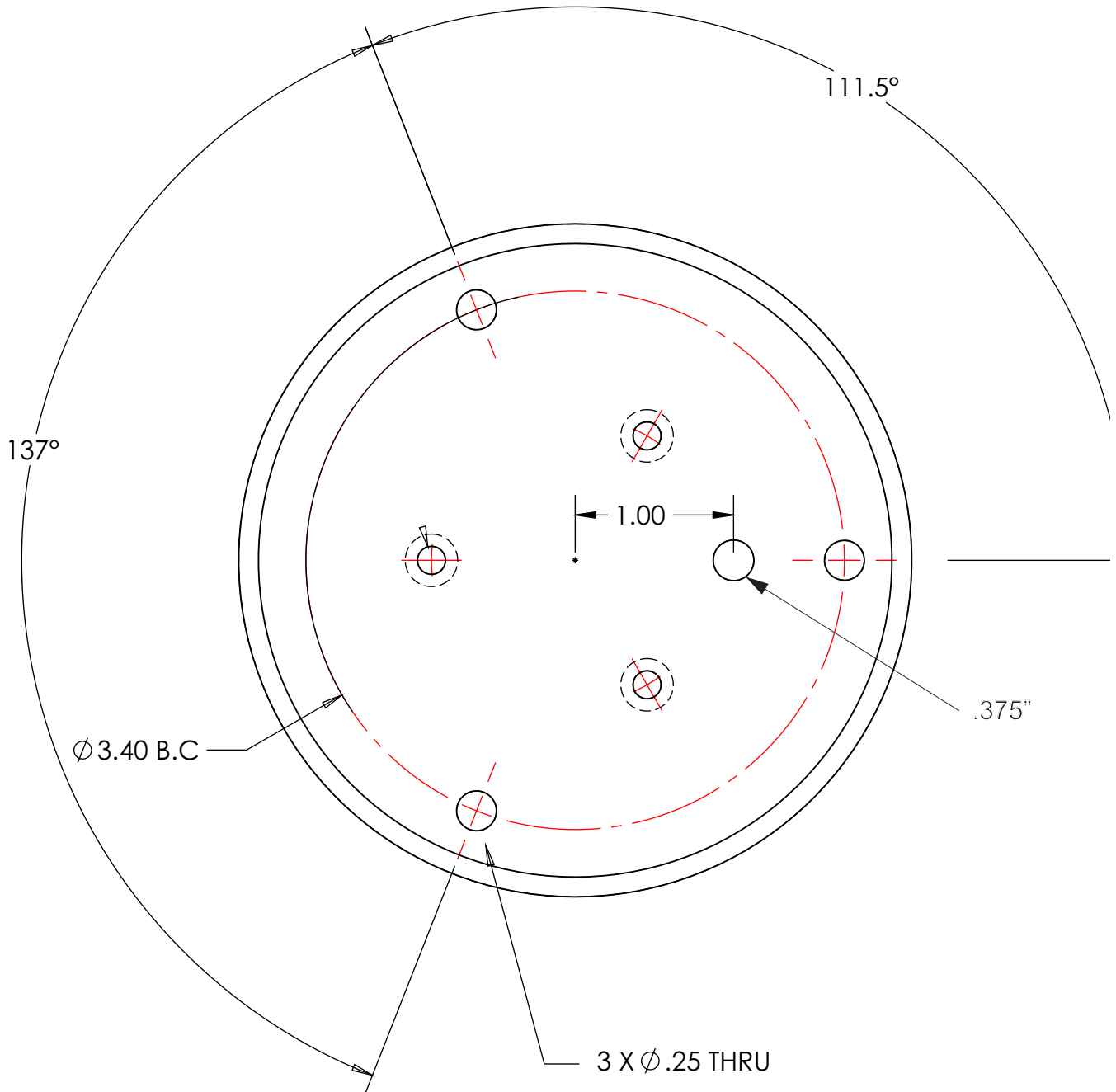

Please print at 100 percent for accurate sizing. Slight scaling may still occur. Therefore, before drilling, it is recommended that all template dimensions be measured for accuracy.



# Need Support?

## Contact Us



1.800.653.8568



support@tacomarine.com



tacomarine.com



50 NE 179th ST  
Miami, FL. 33162



@tacomarine



@taco\_marine

# TACO Marine®

# TACO<sup>®</sup>

MARINE

INSTRUCT-GS-850/950