

4

3

2

1

REVISIONS				
ZONE	REV.	DESCRIPTION	DATE	APPROVED

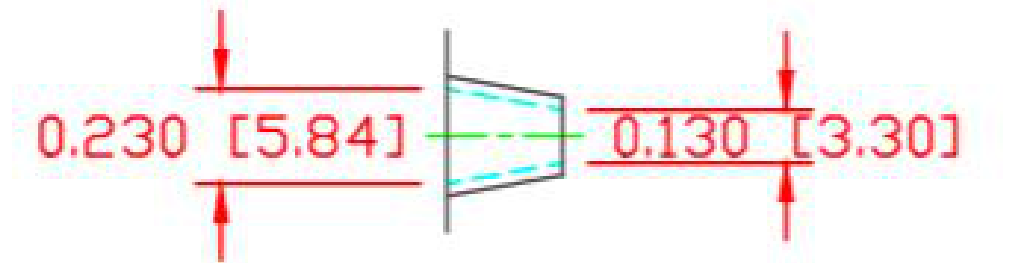
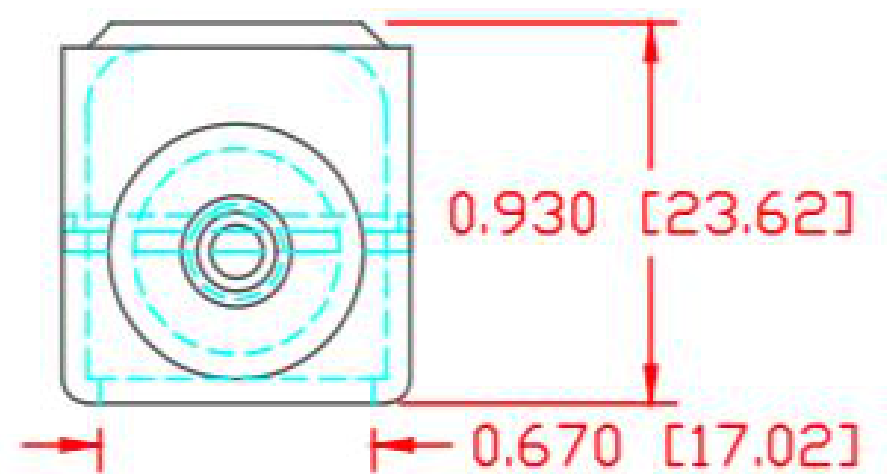
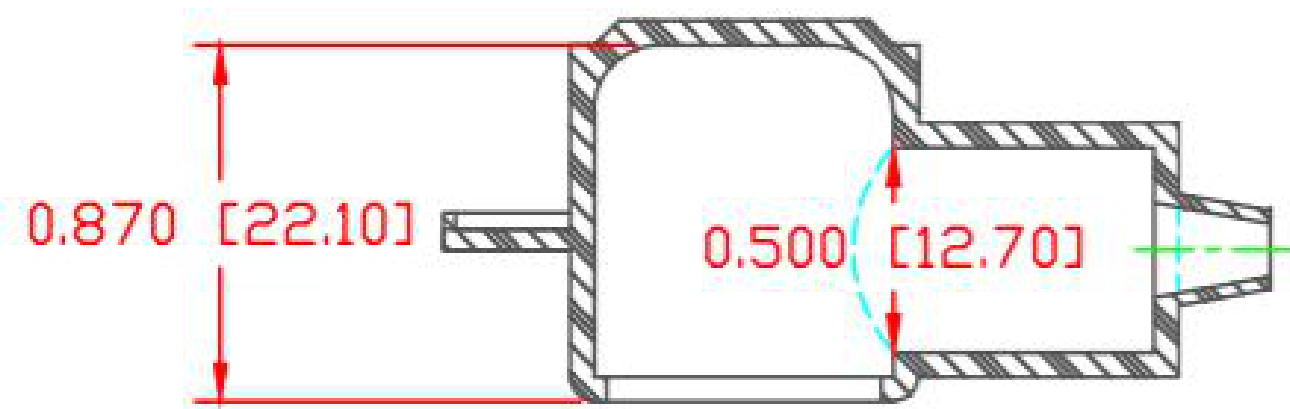

SECTION A-A
 TYP. WALL THICKNESS = .060" [1.5]
 SEAL NO. 1 SHOWN

SEAL THICKNESS = .030" [.8]
 NO. 1
 Wire Gages
 18 - 10

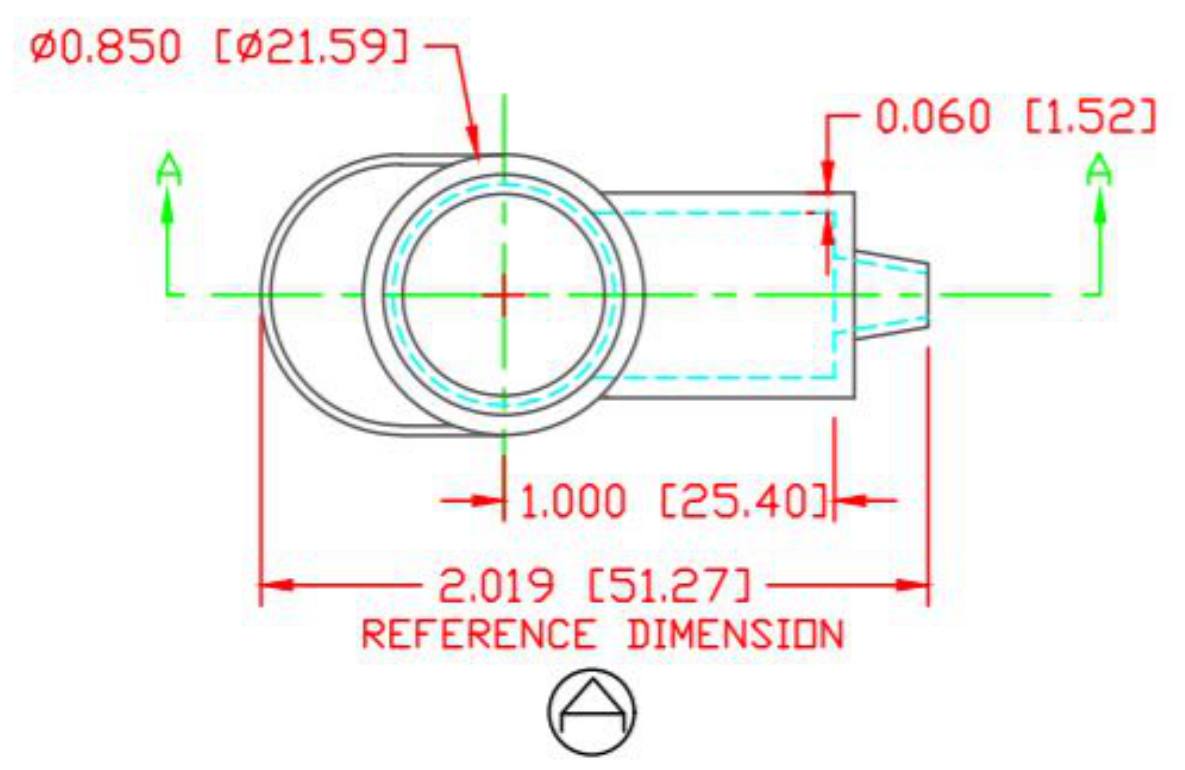

MATERIAL PART NO:	1101650102
MATERIAL:	PVC
VENDOR PART NO:	9812-65-RED 683
SHORE DUROMETER:	"A" 10 SEC. 65
SPECIFIC GRAVITY:	1.34
ULT. ELONGATION %:	400
MELTING TEMP:	315-335 F [157-168 C]
BRITTLE TEMP:	-54 F [-48 C]
Tensile Strength PSI:	1550 PSI
Dielectric Strength, v./mil:	511
U.L. Rating:	V2

<small>UNLESS OTHERWISE SPECIFIED, DIMENSIONS ARE IN MILLIMETERS</small> .XX = ±.13 ANGULAR = ± ° .XXX = ±.050 FRACTIONAL = ±	DRAWN	B Glad	09/17/2018	 Egis Mobile Electric 3135 Mercer Ave, Ste 102 Bellingham, WA 98225, USA
	CHECKED			
	APPROVED			
	DO NOT SCALE DRAWING BREAK ALL SHARP EDGES AND REMOVE BURRS			
THIRD ANGLE PROJECTION	THIS DRAWING AND THE INFORMATION CONTAINED WITHIN IT ARE CONFIDENTIAL AND MAY NOT BE COPIED OR DISCLOSED WITHOUT THE WRITTEN PERMISSION OF EGIS MOBILE ELECTRIC.			TITLE 4218 Insulator - Stud Cable Cap 0.73 in Dia
	SCALE	NTS	WEIGHT	SIZE C DWG NO. SHEET 1 of 1

4

3

2

1