



BROCHURE

ECHOPILOT

## Forward Looking Sonar FLS 3D

Daniamant design and manufacture all of our products in line with the relevant worldwide approvals, technical specifications, current legislation and International directives.

Our mission is to achieve World class performance through partnerships with our suppliers, customers and employees, providing products and services that enhance the safety and security of our customers.

### Daniamant products cover 12 key areas:

- Lifejacket Lights
- Liferaft Lights
- Lifebuoy Lights
- Intrinsically Safe Lights
  - Special Lights
  - LED Flares
- Forward Looking Sonars (FLS)
  - Bridge Navigational Watch Alarm System (BNWAS)
  - Salinometers
  - Oil Level Alarm
  - Electronic Inclinator
- Agency for a range of world-renowned safety product brands (supplied to the Danish market)

### Further Information

For further information on our products, please see our website: [www.daniamant.com](http://www.daniamant.com)

### Introduction

The FLS 3D is one of the best proven Forward Looking Sonar technologies on the leisure market. The FLS 3D displays a 3-dimensional representation of the underwater scene ahead of the boat. The seabed terrain and potential hazards are shown, for the first time, with unparalleled realism.

The FLS 3D comes with twin retractable transducers to ensure complete forward coverage whatever the hull form. The view ahead is 60 degrees in the horizontal plane, over 90 degrees in the vertical plane and the forward range is up to 200 m and 100 meters depth.

The Transducers comes in two sizes, 5" and 10" depending on the size of the hull.

The transducers come with three different types of skin fittings to ensure they will fit any type of hull. You can choose between Bronze, steel or aluminum depending on your hull.

The importance with Forward Looking Sonars is the depth to range ratio. The FLS 3D has a staggering 20 x depth ratio! This means that you will see 100 meters ahead with only 5 meters of water underneath your boat.

The FLS 3D has ground breaking technology of Real-Time Forward Looking Sonar. The display updates every one second so the captain will always be updated on what is ahead of their boat.

### Features

- Skin Fittings Available in Bronze, Steel and Aluminum
- 20 x Depth to range ratio. 5 meter depth = 100 meter range
- Real time system
- Screen updates every 1 second (depending on range)
- 200m forward range
- 100m depth range
- 200KHz frequency
- Twin retractable transducers
- Multiple display options
- Outputs: HDMI, VGA
- Colour coded depth
- Data cable of up to 100m
- Beam width 90 degrees (vertical plane)
- Beam width 60 degrees (horizontal plane)
- Easy Installation

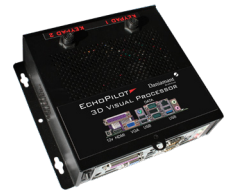

Visual Processor



Transducer Interface

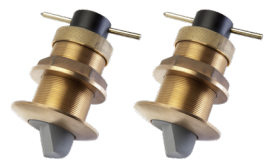

Transducers  
Port & Starboard



Keypad

**Daniamant A/S**  
 Industrivej 24C  
 3550 Slangerup  
 Denmark

Tel +45 47 37 38 00  
 Fax +45 47 37 38 09  
 info@daniamant.com

**Daniamant Ltd**  
 Unit 3, The Admiral Park  
 Airport Service Road  
 Portsmouth, PO3 5RQ  
 United Kingdom

Tel +44 23 92 67 51 00  
 Fax +44 23 92 67 51 01  
 sales@daniamant.com

## Overview

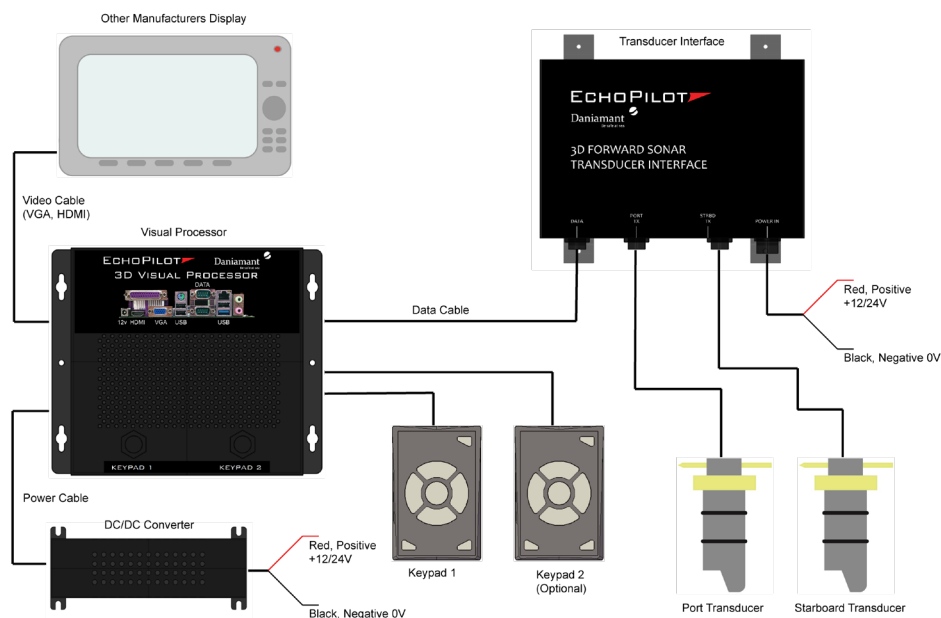

## Standard Kit

- Visual Processor
- Transducer Interface
- 2 x 5" Transducers with 2 meter cable
- 2 x 5" Bronze Skin Fitting
- Keypad
- Data Cable
- Power Cable
- HDMI Cable
- 2 x Transducer Extensions Cable, 10 meter

## FLS 3D Visual

