

Importance of Proper Transducer Selection & Installation

DEEPER.
BROADER.
CLEARER.

GAME CHANGING TECHNOLOGY.

Importance of a Vertical Beam

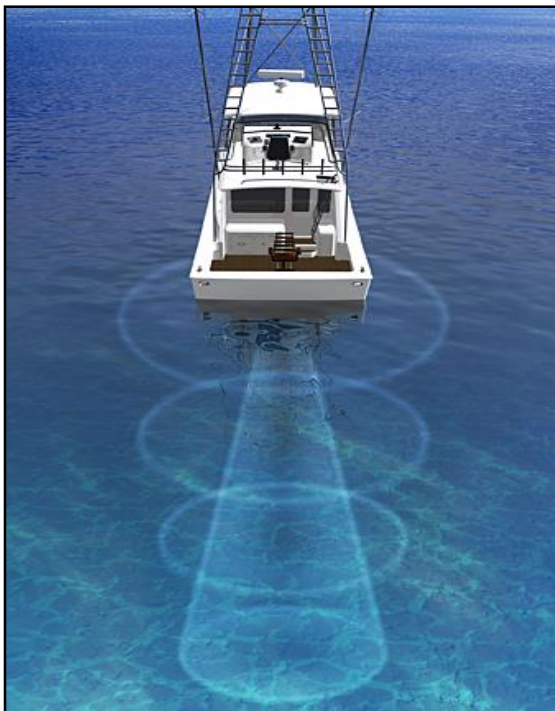

Good

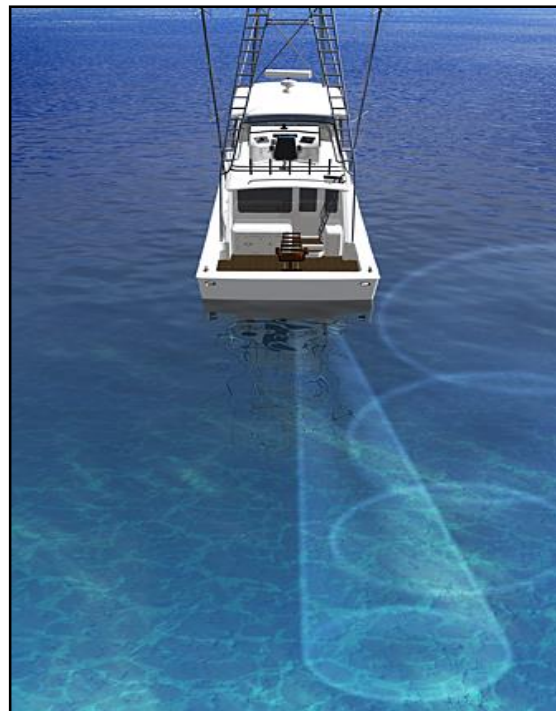

Bad

Regardless of mounting style, a properly installed transducer delivers a vertical beam that aims straight down toward the bottom, resulting in strong echo returns and accurate depth readings.

Optimum Fishfinder Performance...



...starts with optimum transducer placement.

Location Selection

Transducer placement should be aft and close to the centerline. It needs to be located low enough that the transducer is in the water at all times.

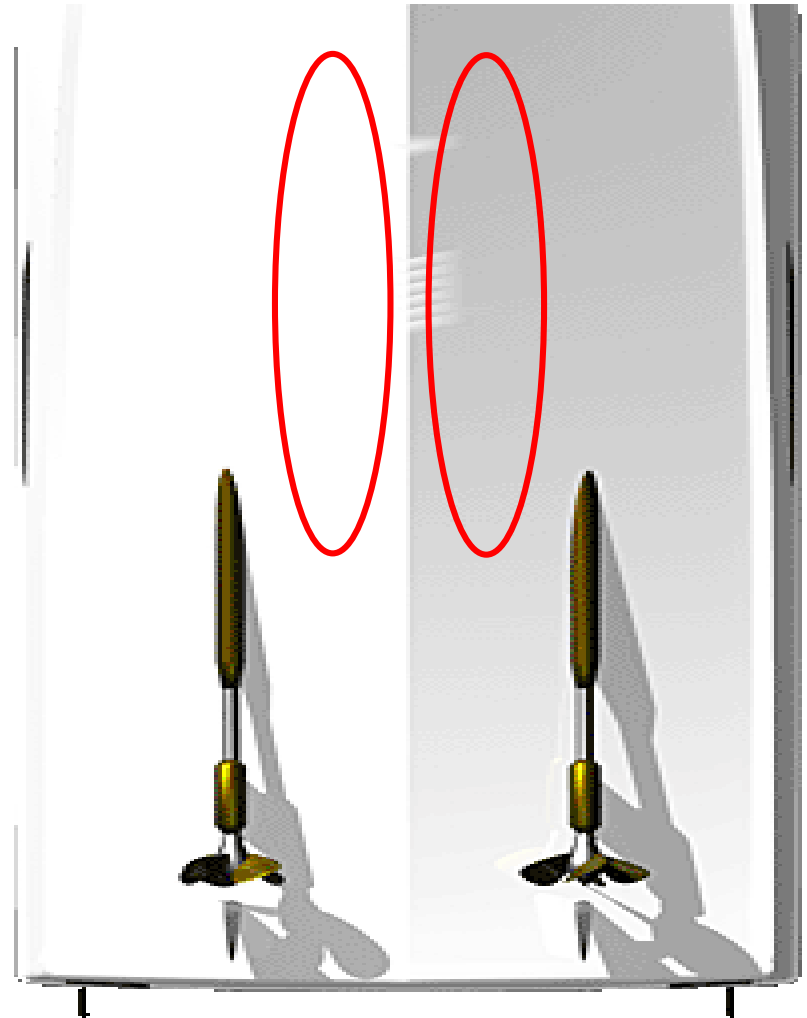

Location Selection

Consider items such as the lifting strap placement into the location as well as trailer bunks and rollers if it is a trailered vessel.

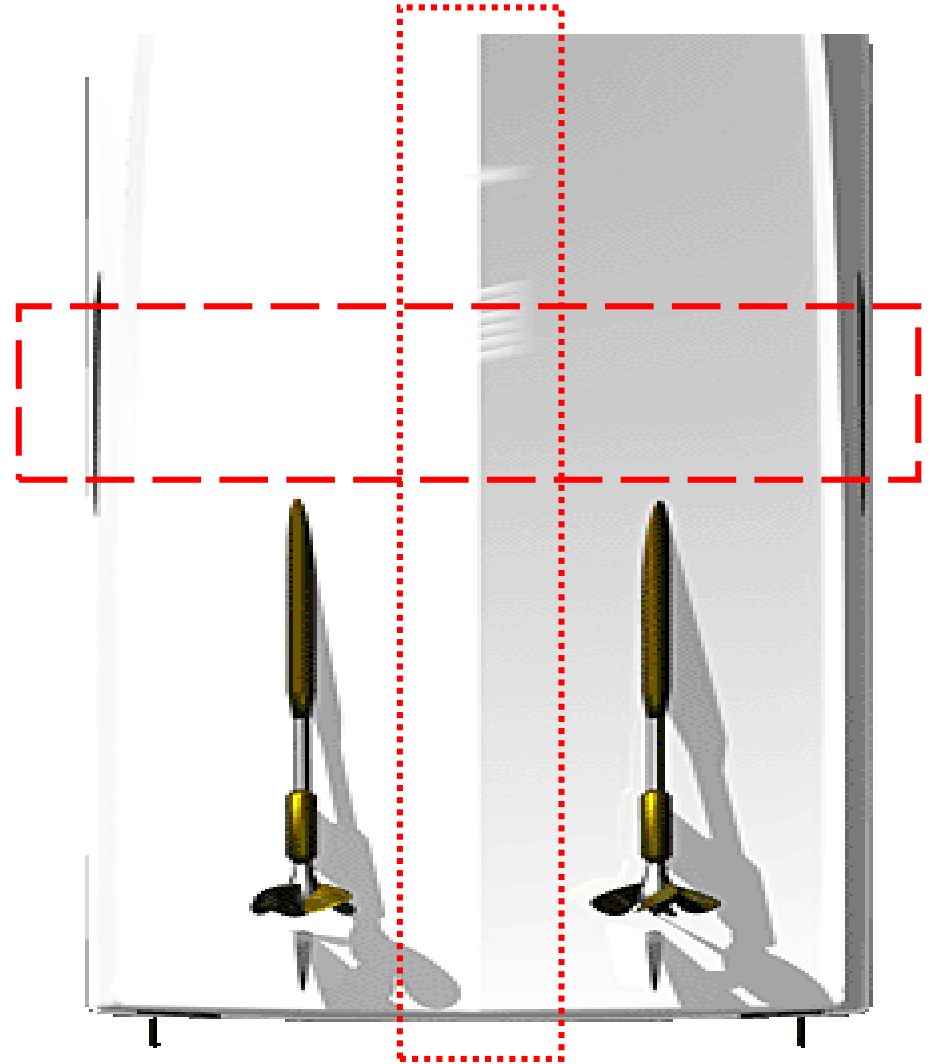

Stepped Hull Installations

Transducers used on stepped hull vessels **must** be located in front of the first step and low to the keel to operate properly.

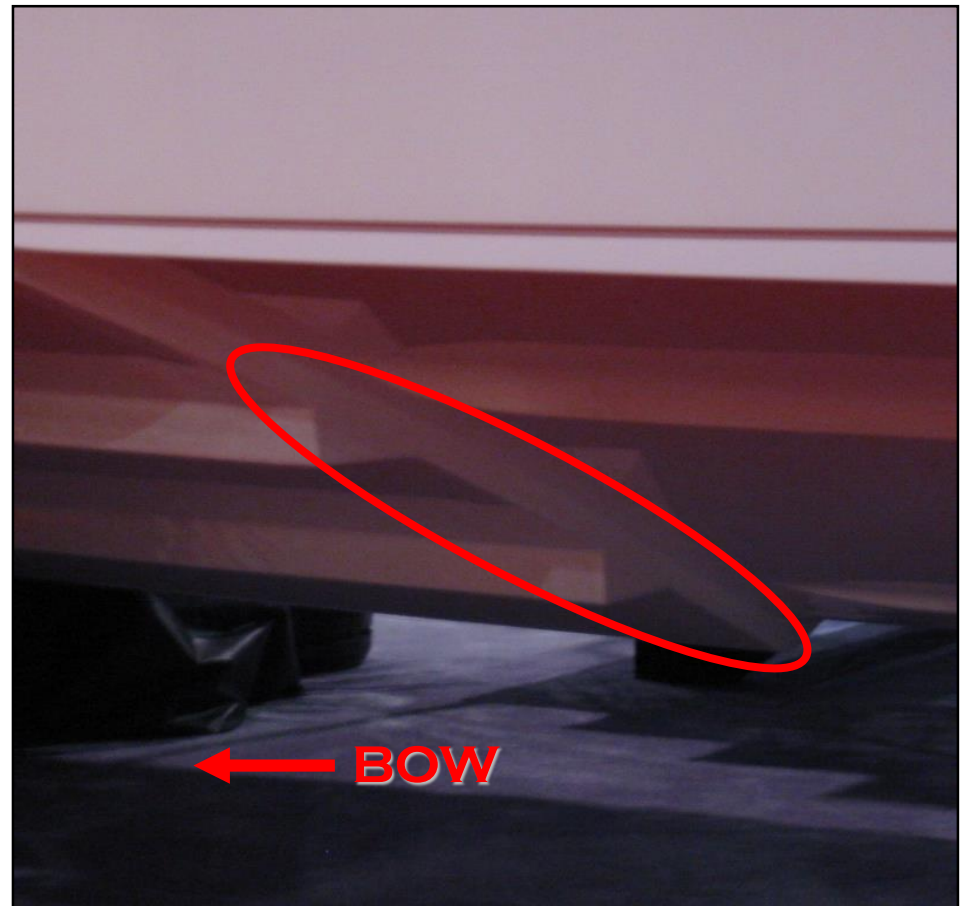

Stepped Hull Aeration

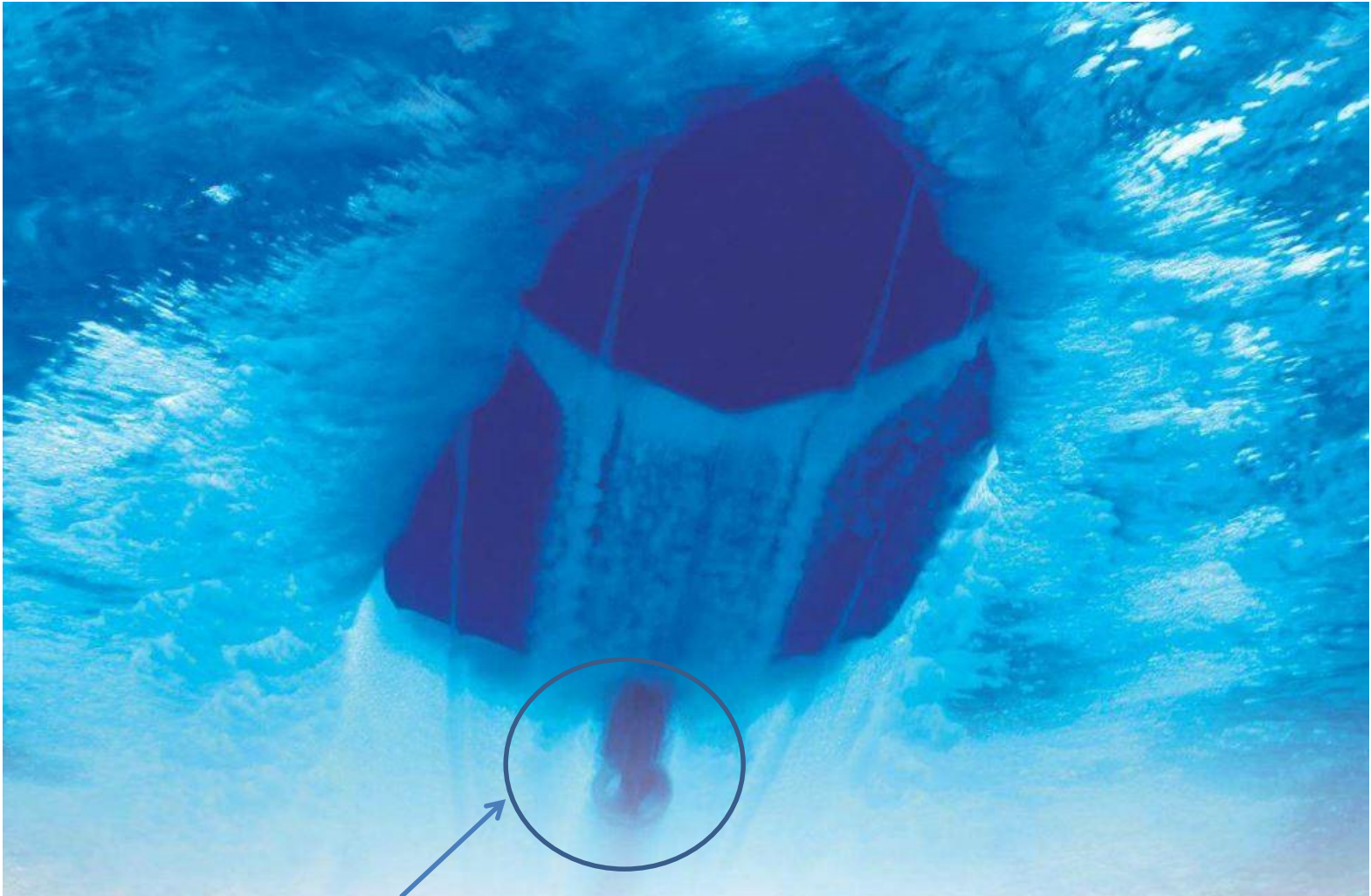

Bubbles create noise and disturbance on the face of the transducer

Installation Guidelines

- Bow thrusters, live well or cooling intakes as well as chines, steps and strakes can all introduce aerated water into the path of the transducer.
- Remember to always look forward all the way to the bow of the vessel to see if there will be any interference in front of the transducer's mounting location.
- If there is an intake 50 feet ahead, in line with the transducer, it will affect performance at high speeds.

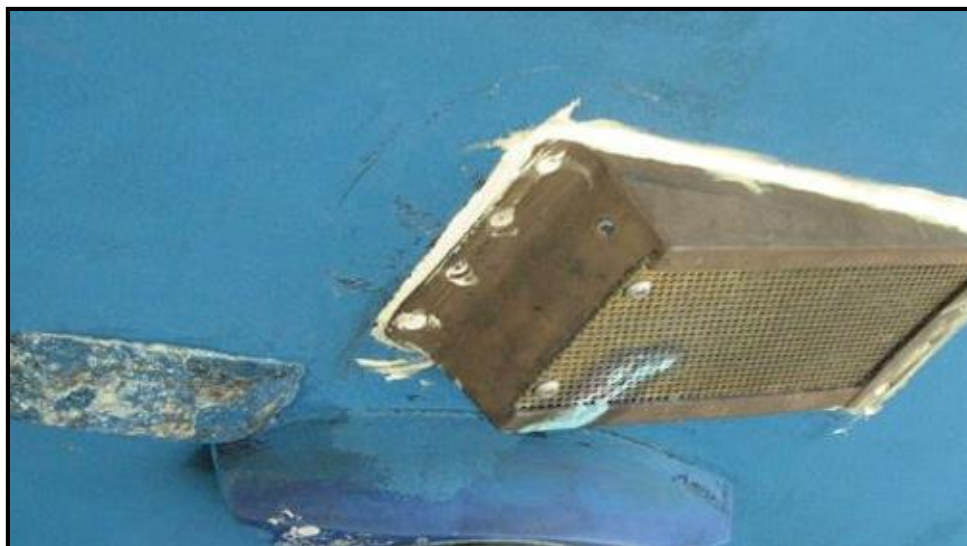

Poorly located transducers installations

This installation of a B164 looks good, however notice the strake 10 feet directly in front of the transducer. This causes turbulence and air bubbles making the transducer stop reading bottom at 12 knots.

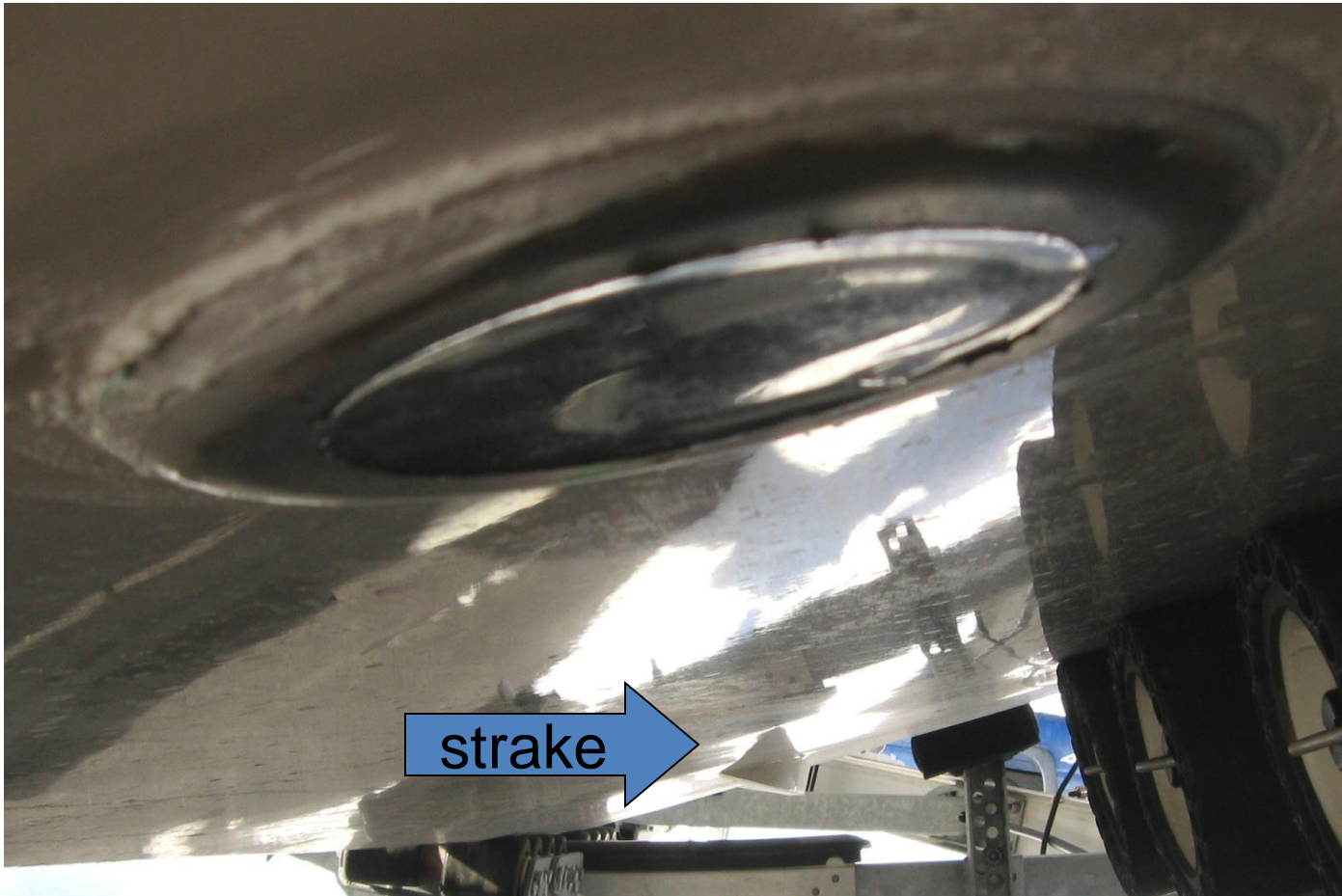

Poorly located transducer installations



Side View



Aft View

This intake shown in the photos above will cause turbulence and send air bubbles over the transducer face as vessel speed increases. The transducer will work great when the vessel is drifting, but will not work well at speed.

Example of a Bad Installation

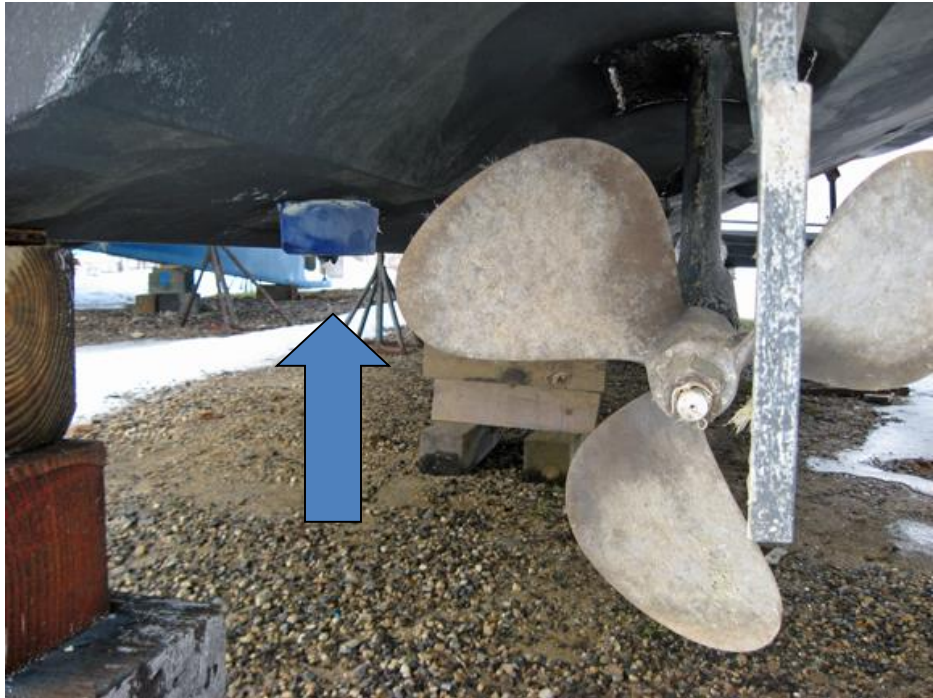

Forward View



Side View

This transducer is mounted too far aft and will be affected by the turbulent water that the starboard propeller will create at **ANY** speed.

Example of a Good B260 Installation



This is an excellent installation of a B260. There are no hull protrusions in front or alongside the transducer. The transducer is also installed away from the keel so that the beam is not shaded. An installation like this will give clear bottom readings up and above 30 knots.

Location Selection

Be sure that the transducer signal will not intersect the prop shaft(s), keel or any other hull projections, and that it is not directly in-line with the prop(s)



Thru-Hull Transducers

B164, SS164, SS264, B175L/M/H
Tilted Element

- Tighten two set screws on the threaded nut



Stainless steel housing—SS164

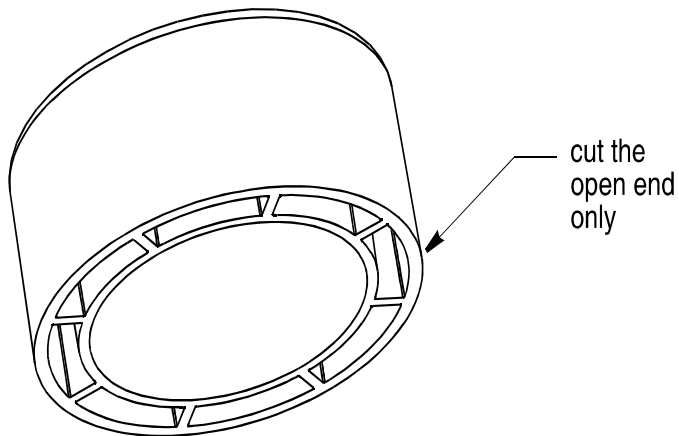
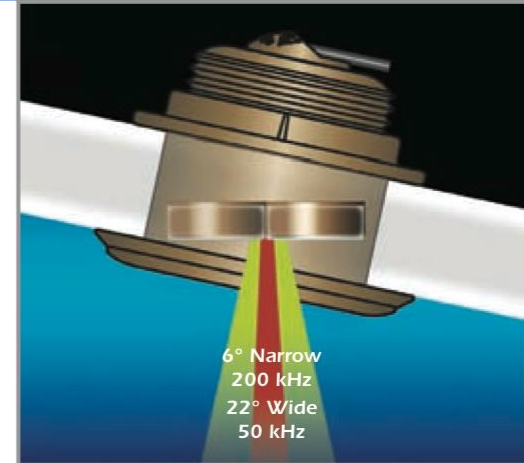

Figure 6. Cutting the spacer

Copyright © 2007 Airmar Technology Corp.

NOTE: After screw makes contact with housing, tighten additional 1/8 - 1/4 turn.

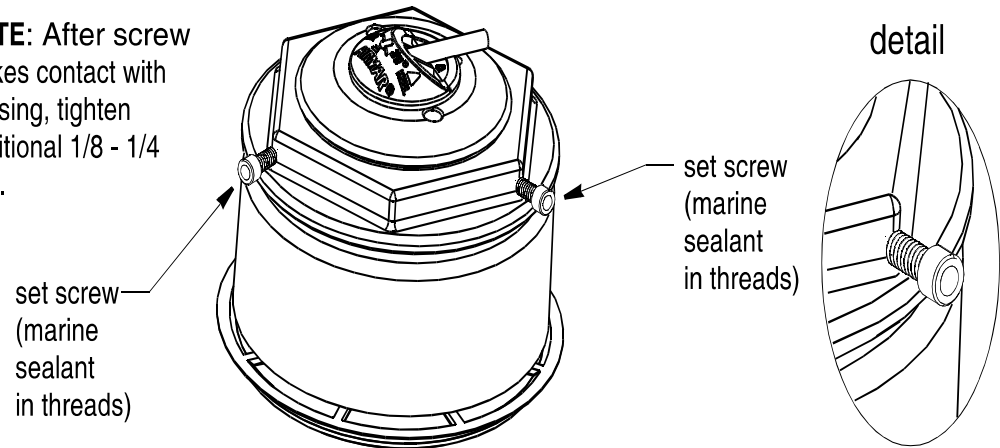

Figure 7. Tightening the two set screws

Copyright © 2008, 2009 Airmar Technology Corp.

Thru-Hull Transducers

B258, B260 Thru-Hulls

- Apply marine sealant as recommended
- Use isolation sleeve on metal hull installations

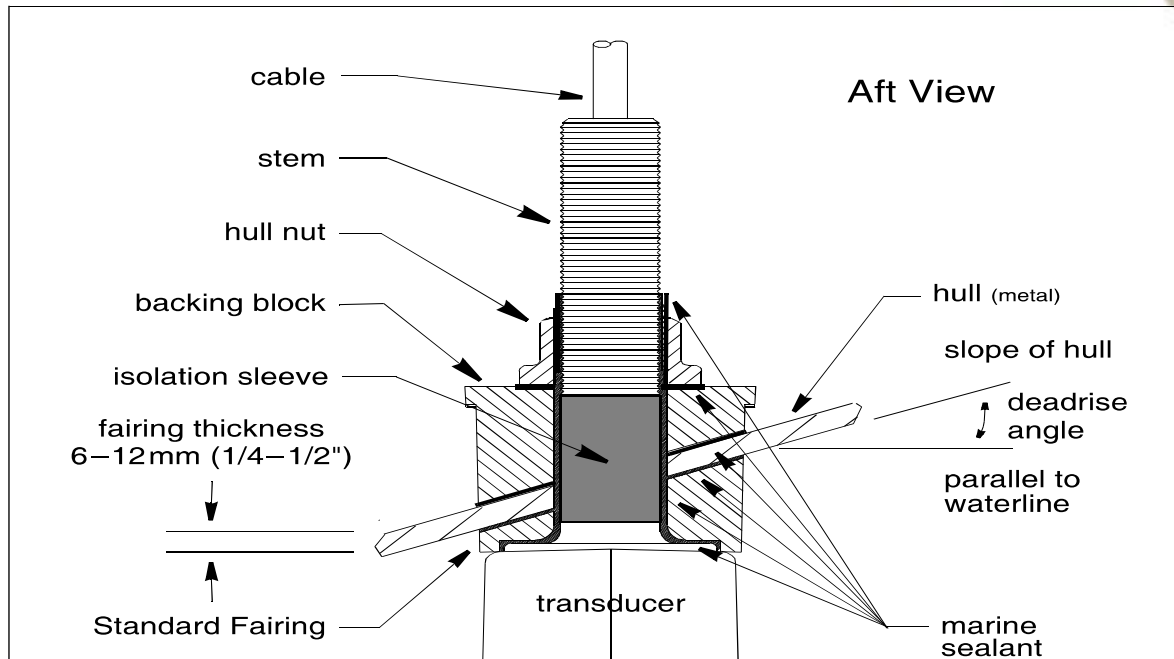
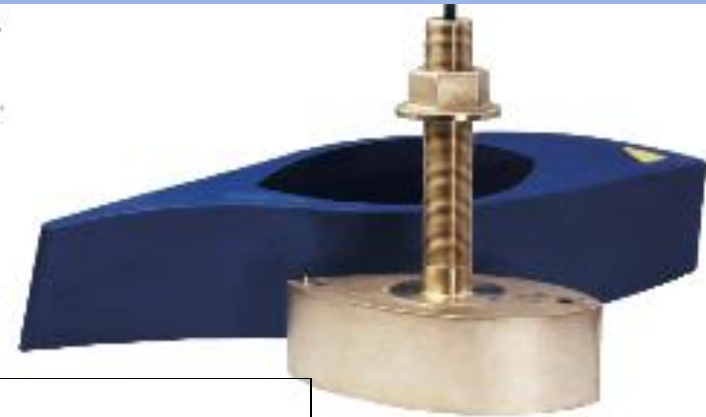

Figure 2. Bedding and installing in a metal hull
(SS258 with Standard Fairing shown)

Thru-Hull Transducers

B258, B260, SS270W, B265LH/LM
Thru-Hulls

- Mounting in cored hulls

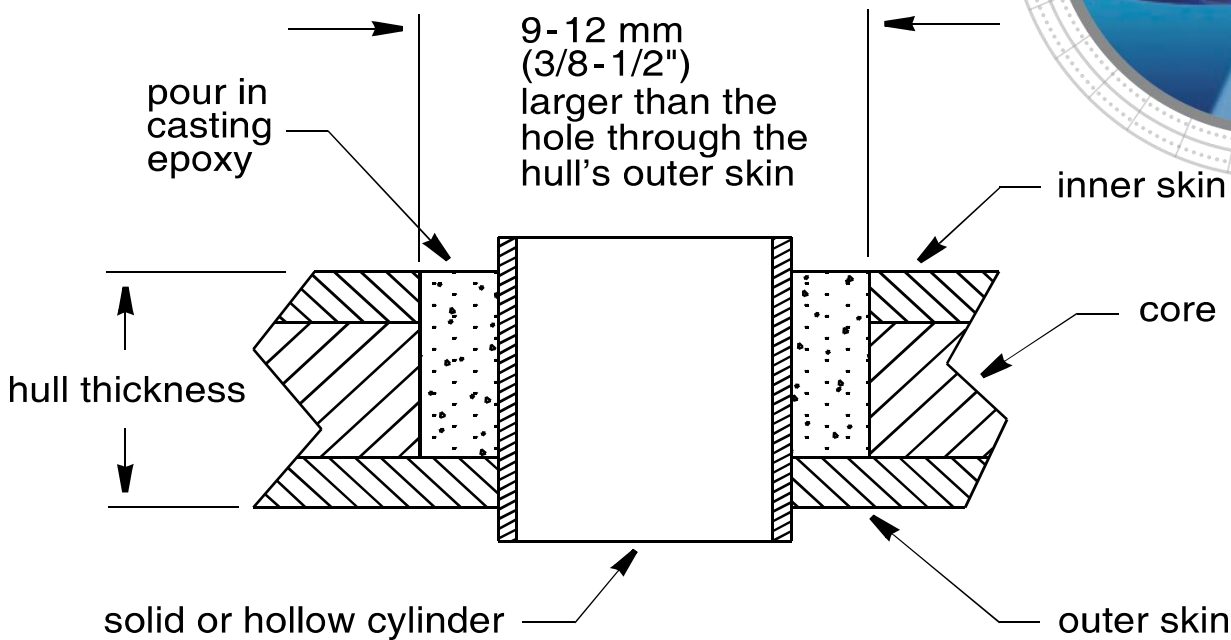
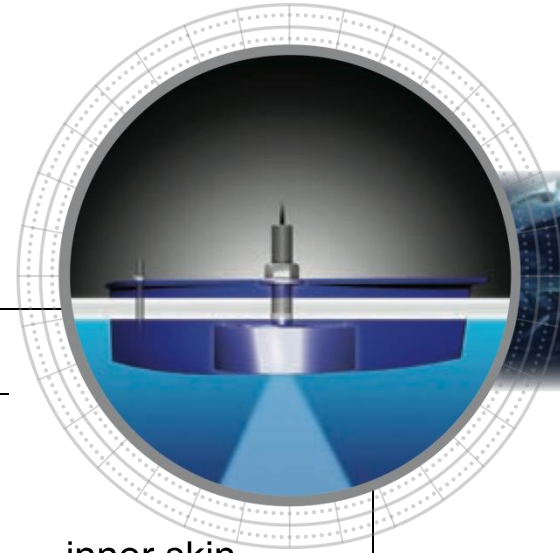

Figure 8. Preparing a cored fiberglass hull

External-Mount Transducers

R99, R109LM/LH, R509LM/LH
External-Mounts



- The Fairing Block **MUST** be Mounted independent of the transducer

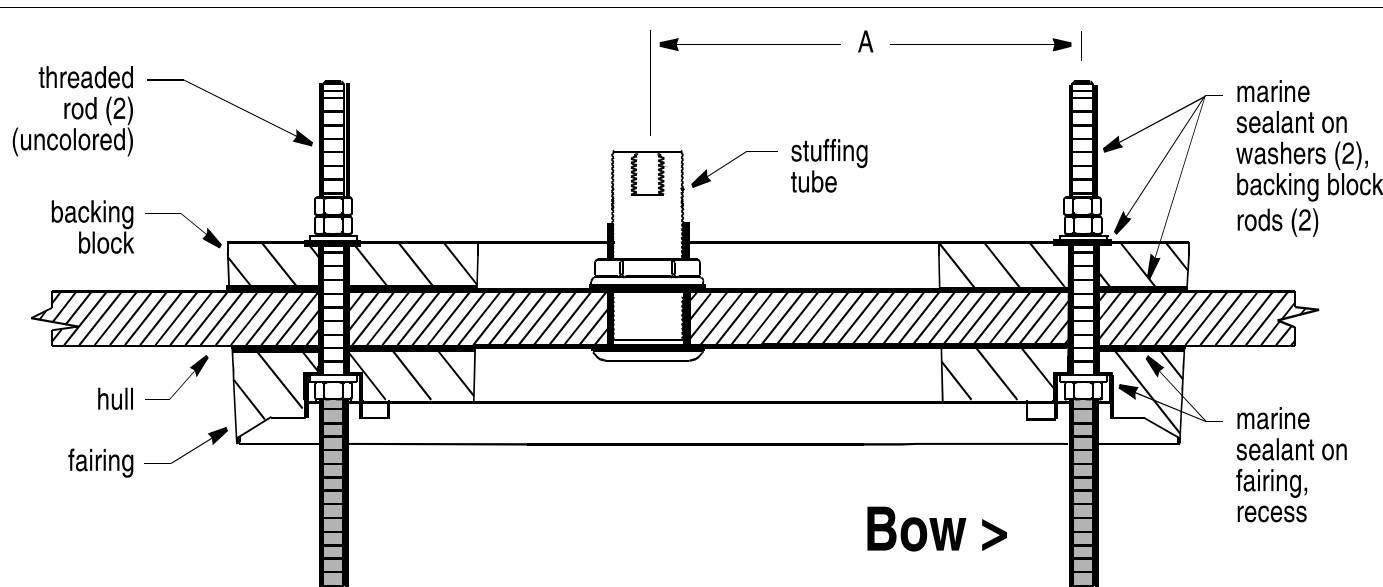

Figure 7. Bedding and installing the fairing and backing block (non-metal hull shown)

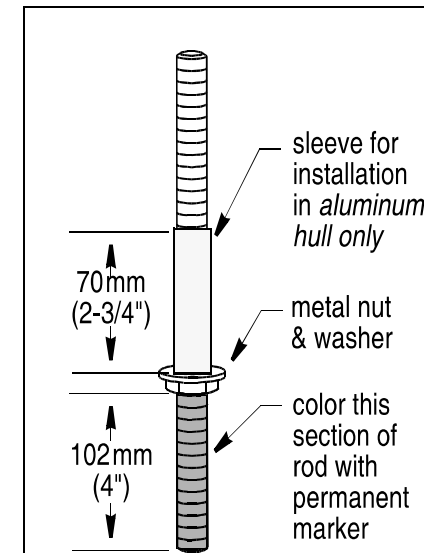

Figure 8. Threaded rod

External-Mount Transducers

R99, R109LM/LH, R509LM/LH
External-Mounts

- The transducer hangs or suspends from the pre-mounted fairing
- Apply marine sealant as indicated

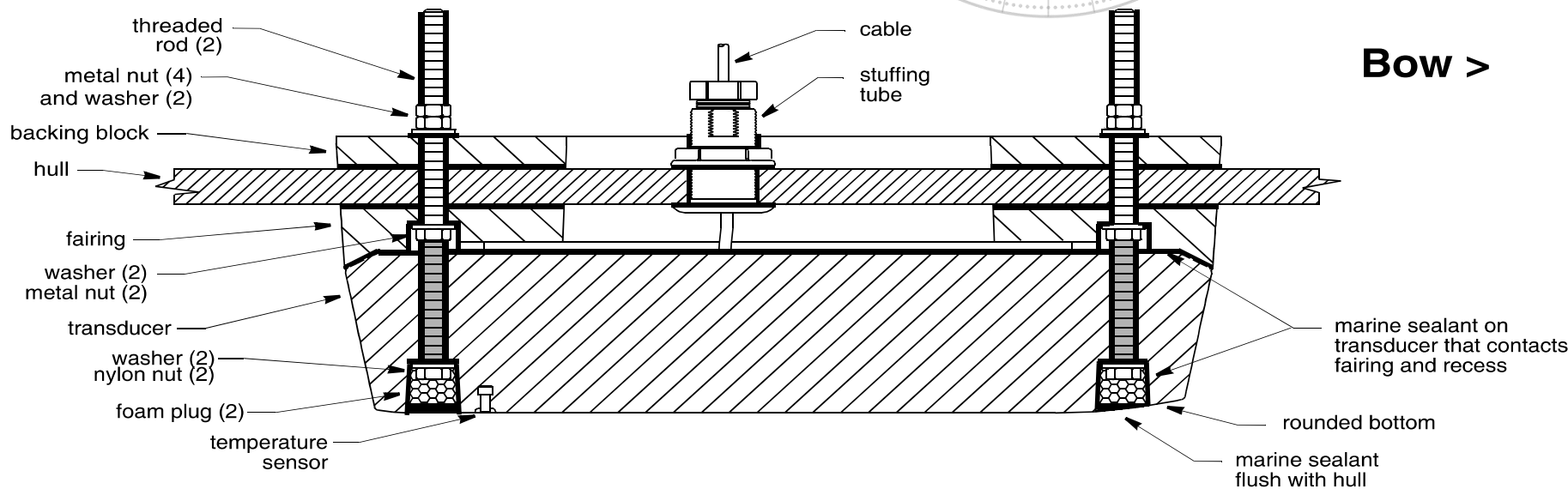
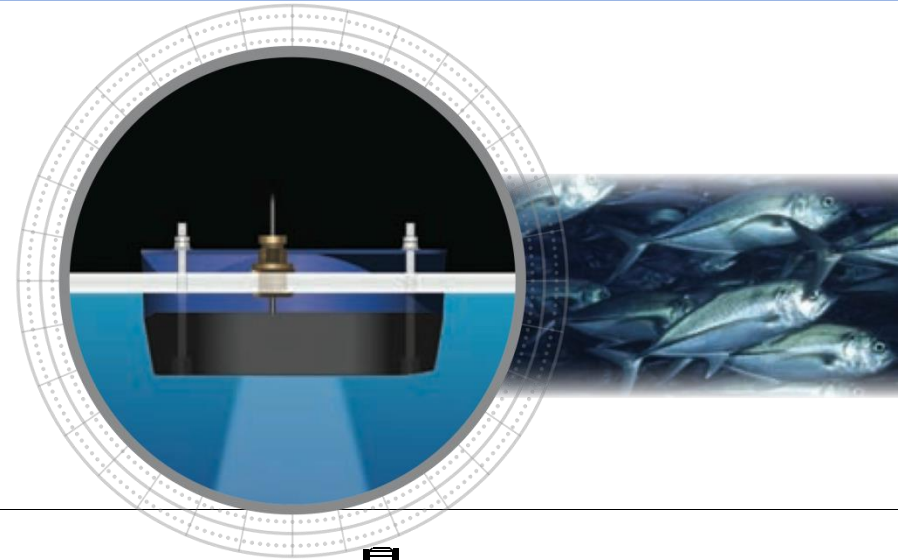

Figure 9. Bedding and installing the transducer (non-metal hull shown)

In-Hull Transducers for Fiberglass Hulls

Mounting:

Sand/grind the fiberglass until rough. Clean the fiberglass, then mount with:

1. Fiberglass Resin (best choice for long-term adhesion)
2. Fusor® 100EZ / T10.
3. 3M 5200,

Filling the tank:

Use non-toxic Marine & RV red/pink anti-freeze

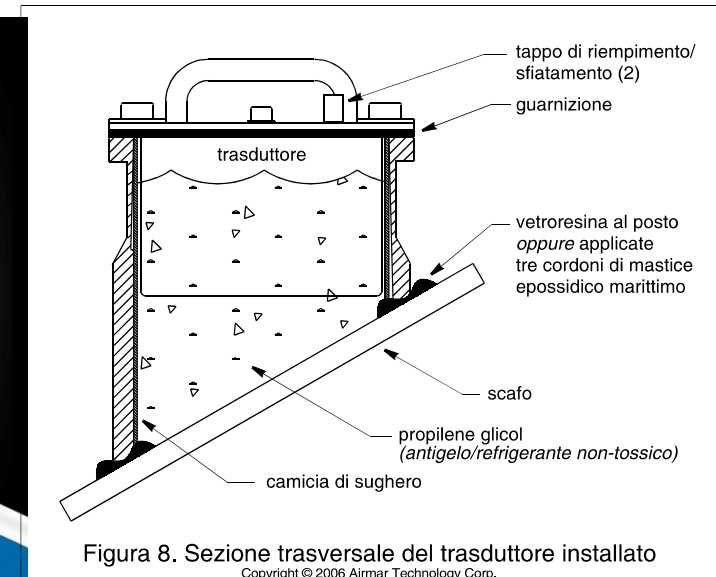

In-Hull Location Selection

The same installation placement guidelines for Thru-Hulls apply for In-Hulls.

The selected location should be aft and close to the centerline so that the transducer is in the water at all times.

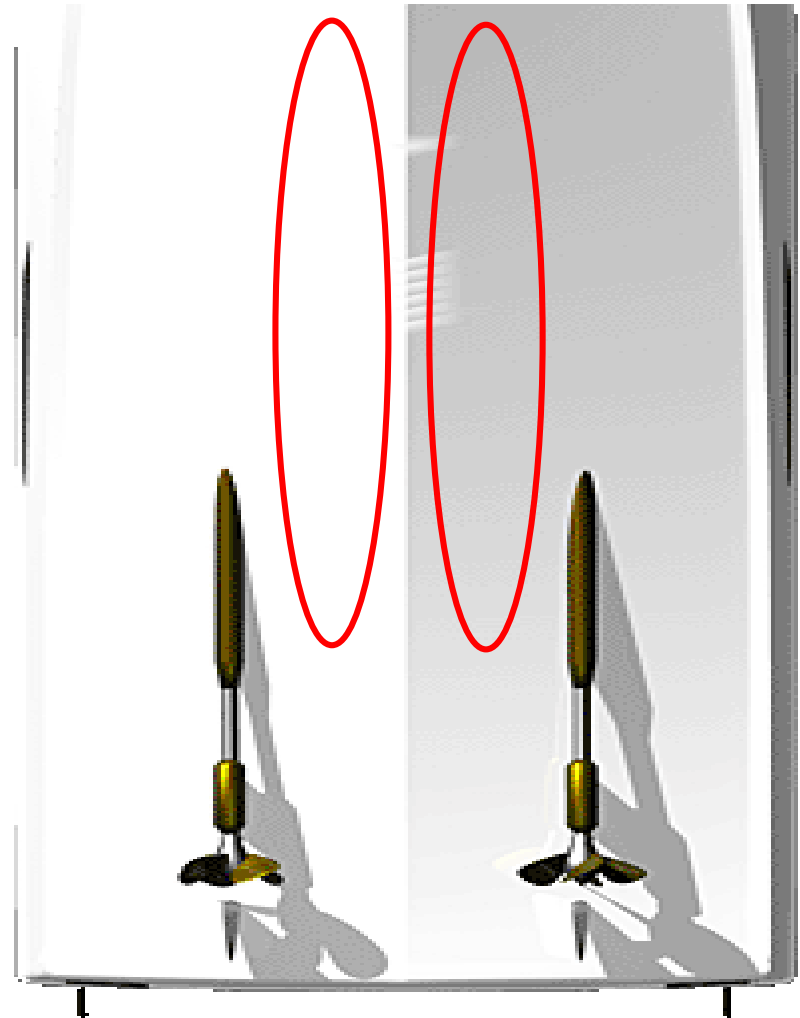

Testing an In-Hull Mounting Location

Before installing the transducer tank, perform one of the 3 methods below in as deep of water as possible. Connect the transducer cable to the fishfinder to verify strong bottom readings.

- A. Flood the area with bilge water.
- B. Place the transducer in a garbage bag and fill with water
- C. Apply a water based lubricant to the transducer face and press against the hull

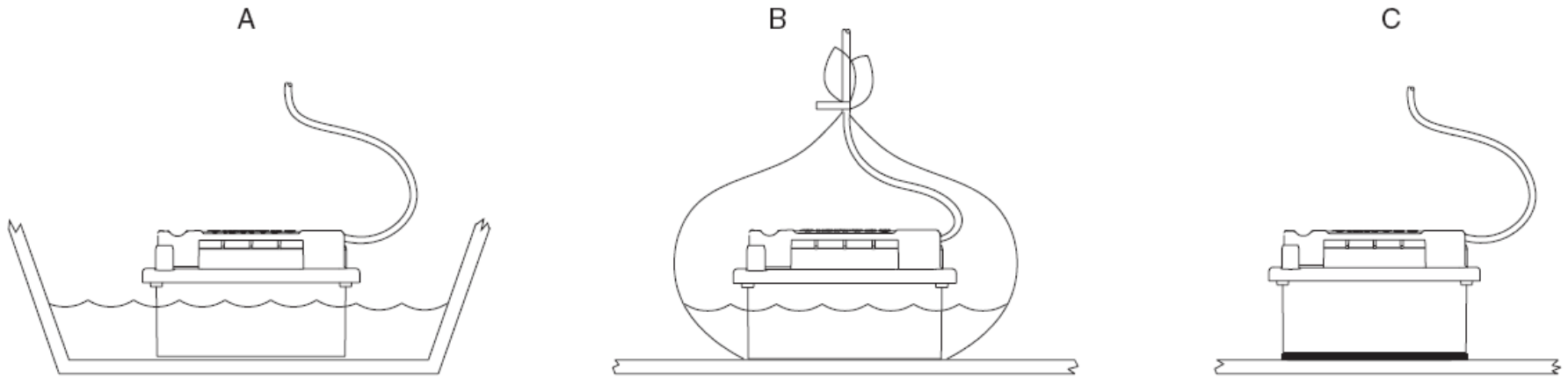

Figure 4. Testing the transducer at the selected location

Custom Installations

- B260 recess mount in the keel – courtesy Mako Marine



Custom Installations

- B260 recess mount in the keel – courtesy Mako Marine



Custom Installations

- B260 recess mount in the keel – courtesy Mako Marine



Custom Installations

- B260 recess mount in the keel – courtesy Mako Marine

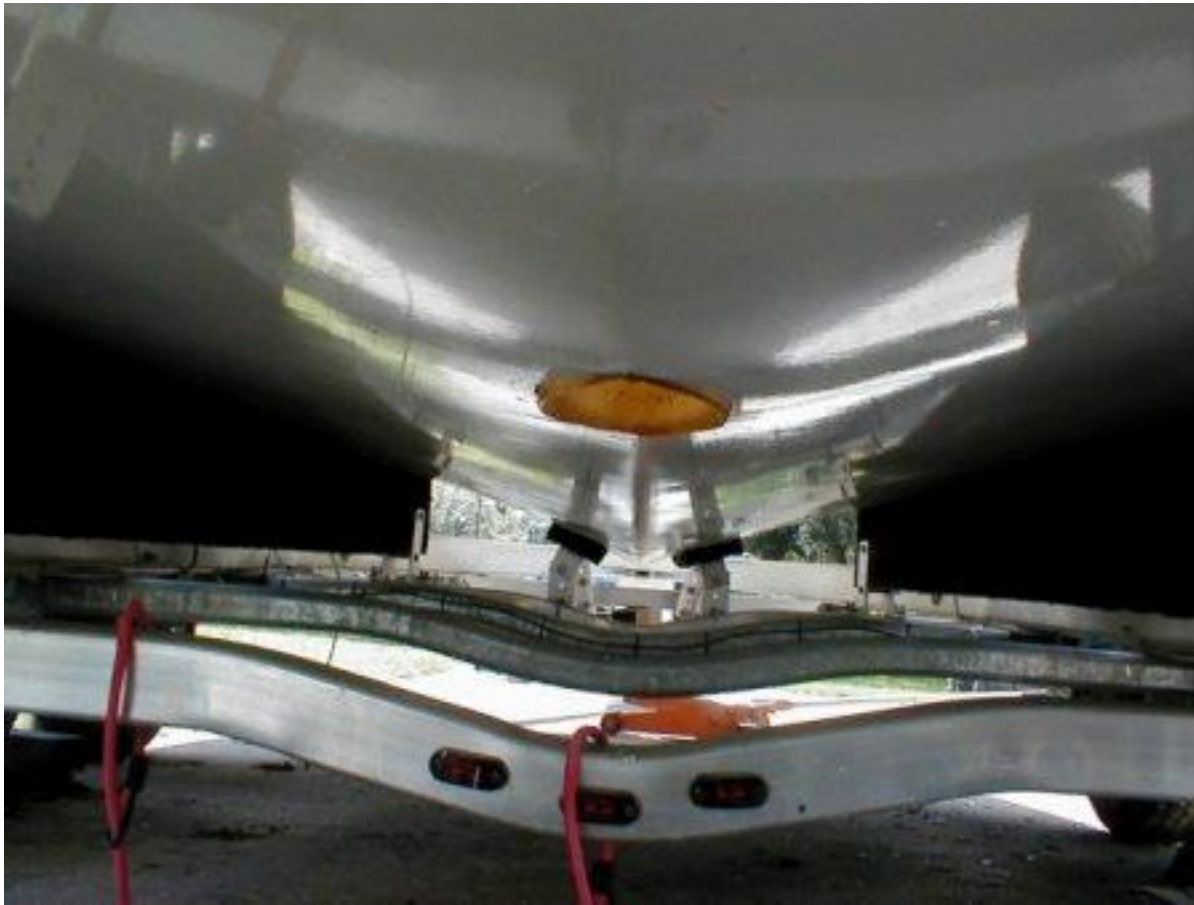

Custom Installations

- B260 recess mount in the keel – courtesy Mako Marine



Custom Installations

- B260 recess mount in the keel – courtesy Mako Marine



Custom Installations

- B260 recess mount in the keel – courtesy Mako Marine



Custom Installations

- B260 recess mount in the keel – courtesy Mako Marine



Custom Installations

- B260 recess mount in the keel – courtesy Mako Marine



Custom Installations

- B260 recess mount in the keel – courtesy Mako Marine



Custom Installations

- B260 recess mount in the keel – courtesy Mako Marine



Custom Installations

- B260 recess mount in the keel – courtesy Mako Marine

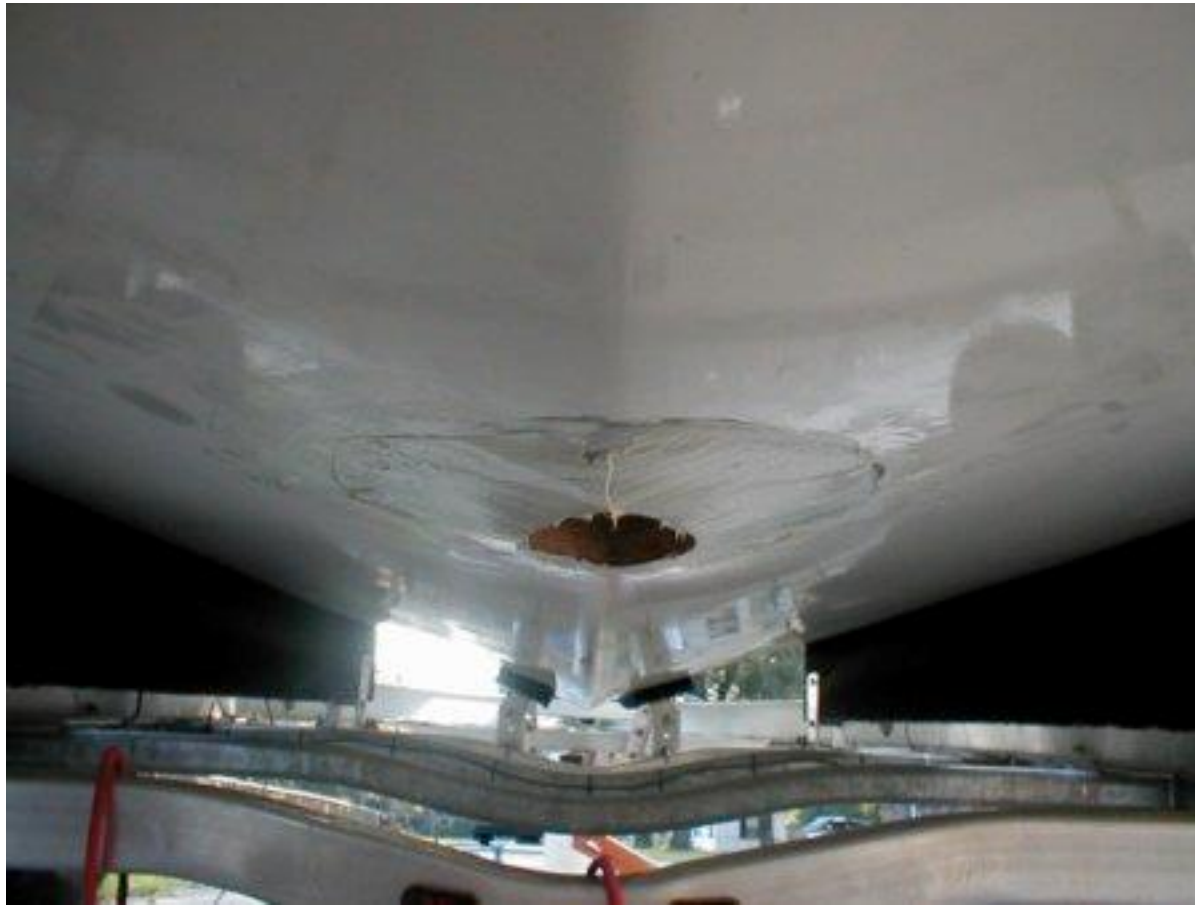

Custom Installations

- B260 recess mount in the keel – courtesy Mako Marine



Custom Installations

- B260 recess mount in the keel – courtesy Mako Marine



Custom Installations

- B260 recess mount in the keel – courtesy Pangaforum



Custom Installations



- Pocket-Mount courtesy Garmin

