

---

# SeaGauge Remote G2

---

## User's Manual

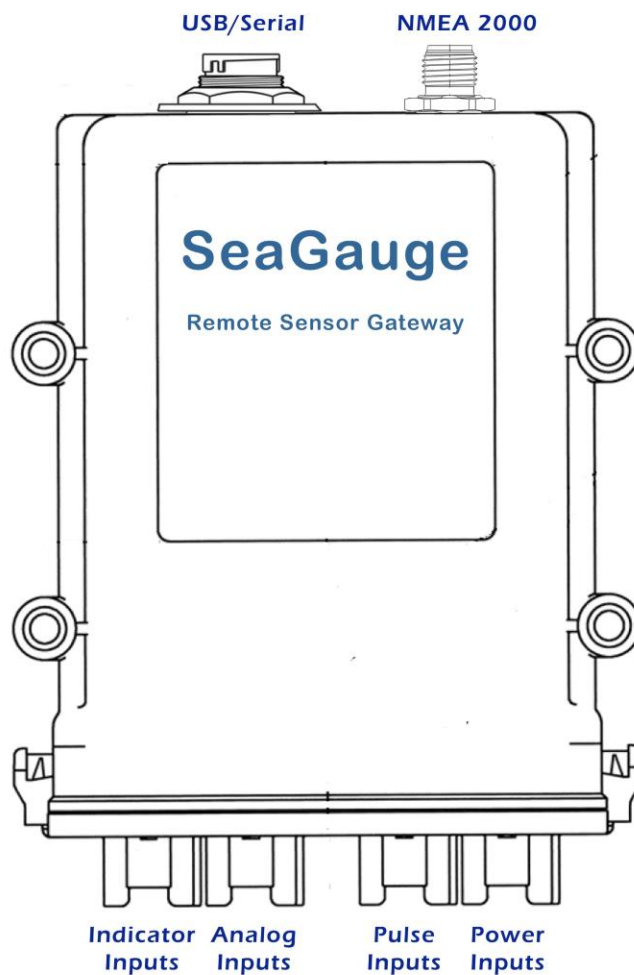

**Chetco Digital Instruments**

Copyright © 2019 Chetco Digital Instruments, Inc.

All rights reserved.

SeaGauge-Remote™ is a trademark of Chetco Digital Instruments, Inc.

vDash™ is a trademark of Chetco Digital Instruments, Inc.

## **WARNING!**

**USE THIS UNIT ONLY AS AN AID TO MONITORING ENGINE PERFORMANCE INFORMATION.**

## **CAUTION**

When showing sensor data, this unit will only show information based on the sender used and its installed position.

The operating and storage temperature for your unit is from -4 degrees to +167 degrees Fahrenheit (-20 to +75 degrees Celsius). Extended storage temperatures higher or lower than specified will cause the liquid crystal display to fail. Neither this type of failure nor its consequences are covered by the warranty. For more information, consult the factory customer service department.

All features and specifications subject to change without notice.

Chetco Digital Instruments may find it necessary to change or end our policies, regulations, and special offers at any time. We reserve the right to do so without notice.

All screens in this manual are simulated.

## **NOTICE!**

Free software upgrades will be available on our website at [http:// www.chetcodigital.com](http://www.chetcodigital.com) as they are released. Please check our website periodically for these and other information as they become available.

Thank you for choosing Chetco Digital Instruments

This device complies with Part 15 of the FCC Rules. Operation is subject to the following two conditions: (1) this device may not cause harmful interference, and (2) this device must accept any interference received, including interference that may cause undesired operation.

**Note:**

This equipment has been tested and found to comply with the limits for a Class B digital device, pursuant to Part 15 of the FCC Rules. These limits are designed to provide reasonable protection against harmful interference in a residential installation. This equipment generates, uses and can radiate radio frequency energy and, if not installed and used in accordance with the instructions, may cause harmful interference to radio communications. However, there is no guarantee that interference will not occur in a particular installation. If this equipment does cause harmful interference to radio or television reception, which can be determined by turning the equipment off and on, the user is encouraged to try to correct the interference by one or more of the following measures:

- Reorient or relocate the receiving antenna.
- Increase the separation between the equipment and receiver.
- Connect the equipment into an outlet on a circuit different from that to which the receiver is connected.
- Consult the factory customer service department for help.

## SPECIFICATIONS

Dimensions: .....6.85” W x 6.3” D x 2.3” H

Input Voltage: ..... 10 - 15 vDC, 12-volt Nominal (24V option)

Processor Frequency:..... 18.432 MHz

Maximum Current:.....800 mA

Operating and Storage Temperature ... -4 to +167 degrees Fahrenheit  
20 to +75 degrees Celsius

Analog Conversion Accuracy :.....10 bits

Sender voltage range:..... 0 - 2.5 volts

Sender voltage resolution:..... 0.0128 volts

Pulse Count resolution: ..... 1 per second

Maximum Pulse Count:..... 250 per second

Analog Channels: ..... 12

Pulse Channels:..... 3

Indicator Status/Switch:..... 12

Common Alarm Out: ..... active High 2.5V, active Low 100 mA current Sink

RS232 Serial Ports:..... 2

USB Slave Port: ..... 1

NMEA 2.0 Instrumentation Sentences \$IIXDR,A \$IIXDR,C \$IIXDR,D \$IIXDR,F  
\$IIXDR,G \$IIXDR,I \$IIXDR,P \$IIXDR,R \$IIXDR,S \$IIXDR,T \$IIXDR,U \$IIXDR,V

NMEA 2000 PGNs PGN 127488, PGN 127489, PGN 127501, PGN 127502, PGN 127505,  
PGN 127508, PGN 127493, PGN 130312, PGN 130311, PGN 130323, PGN 130306, PGN  
127250, PGN 127257, PGN 127251, PGN 126992, PGN127245

Chetco Digital Remote Display support protocol – G18S, G12C, G24C, G32C

# Table of Contents

---

Table of Contents .....	5
Introduction.....	8
Welcome .....	8
.....	9
Analog Inputs –.....	9
Optional EGT inputs –.....	9
Pulse Inputs -.....	10
Alarm Output .....	10
Indicator Port –.....	10
Serial Interface –.....	10
Slave USB interface –.....	10
ENET/WiFi Interface –.....	10
What You Get .....	11
Unit.....	11
Cables .....	11
Operation .....	13
Sensor Inputs .....	13
Display Label Table.....	15
Channels Table .....	16
Calibration Tables.....	19
OPTIONS Table.....	21
Connectors.....	23
.....	24
System Power.....	25
Pulse Inputs.....	26
Sensors .....	27
Indicator/Status.....	30
Sensor Dip Switches .....	32
Ports .....	35
LED INDICATORS.....	40
Board Jumpers .....	41
PORT SWITCHES.....	44
FIRMWARE UPDATE SWITCH .....	45
Installation.....	46
Mount.....	46
Power .....	47
Alarm.....	47
Pulse input.....	47
Reference Voltage.....	47
Signals.....	48
Calibration Tables .....	49
Serial Port Protocols .....	51
NEXT MENU.....	52

SET Function.....	52
Real-time data.....	52
Program Mode .....	52
Color Display Protocol.....	54
NMEA 2000 PGNs .....	55
PGN 127488 Engine Parameters Rapid .....	56
PGN 127489 Engine Parameters Dynamic .....	56
PGN 127508 Battery Status.....	56
PGN 127505 Fluid Level.....	57
PGN 127493 Transmission Parameters .....	57
PGN 130312 Temperature .....	57
PGN 130316 Temperature Extended.....	57
PGN 127497 Trip Parameters .....	58
PGN 127501 Binary Switch Status.....	58
PGN 127502 Switch Command Control .....	58
One Year Warranty.....	59



# Introduction

## Welcome

Thank you for purchasing a Chetco Digital Instruments product. SeaGauge-Remote™ provides custom instrumentation in a rugged compact design. Its user defined calibration tables and alarms allow it adapt to and monitor many different sensors from a single location.

SeaGauge-Remote™ will interface directly with a personal computer via serial or USB interfaces. Optional display heads provide real-time display of instrumentation in remote locations.

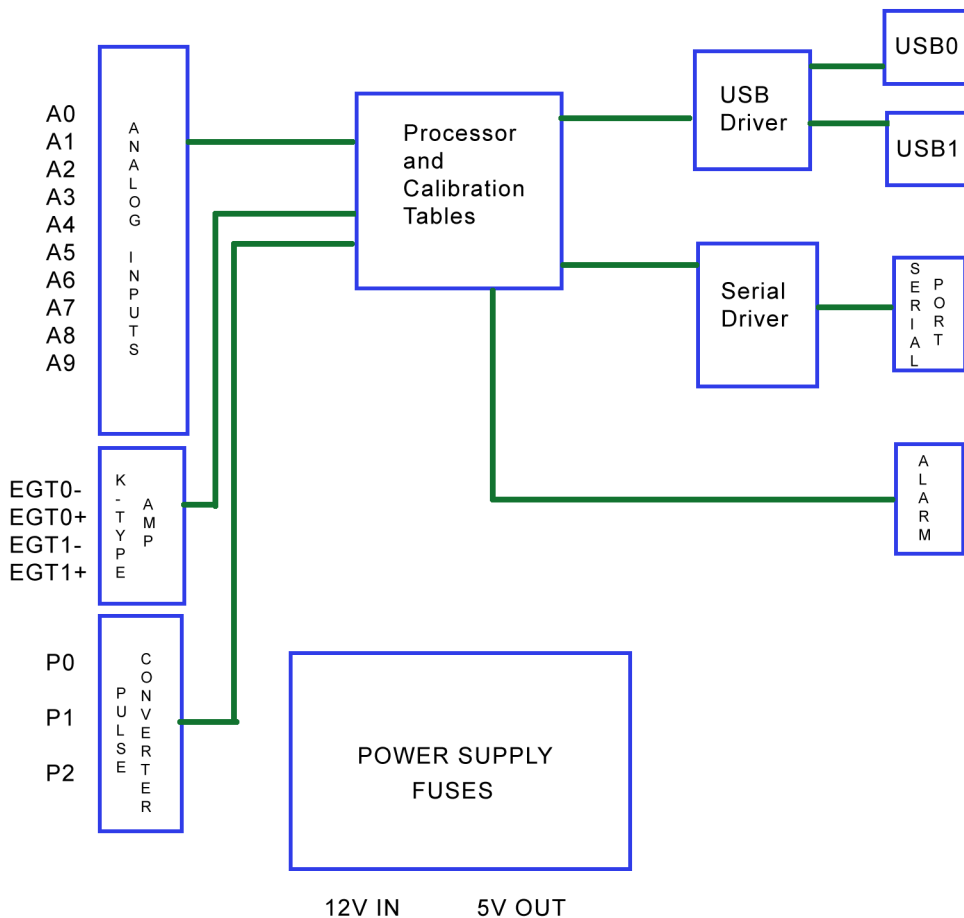



# SeaGauge-Remote G2 User's Manual

## SeaGauge

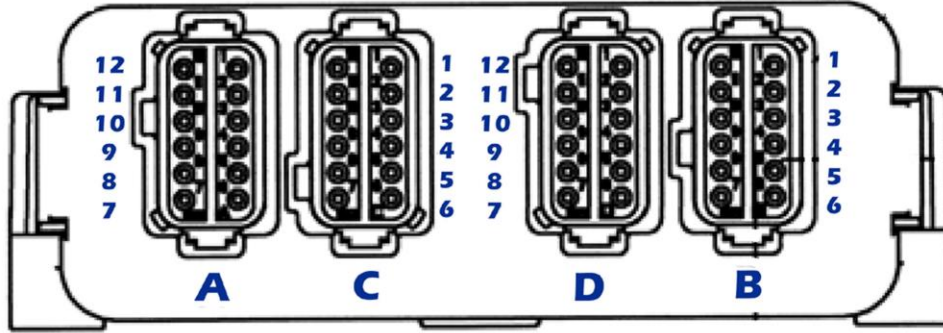

netGauges - A (gray)

12=Status 1	1=Status 6
11=Status 0	2=Status 7
10=Status 2	3=Status 5
9= Status 3	4=Status 4
8= Status 8	5=Status 11
7=Status 9	6=Status 10



netGauges - C (green)

12=VOLT 1	1=VOLT 0
11=LEVEL 1	2=LEVEL 0
10=TEMP 1	3=TEMP 0
9=PSI 1	4=PSI 0
8=PSI 3	5=PSI 2
7=TEMP 3	6=TEMP 2



netGauges - D (brown)

12=PULSE1	1=PULSE0
11=GROUND	2=GROUND
10=PULSE2	3=ALARM
9=---	4=---
8=---	5=---
7=---	6=---



netGauges - B (black)

12=Ground	1=Ground
11=12-24VDC	2=12-24VDC
10=---	3=---
9=---	4=---
8=---	5=---
7=---	6=---

**Analog Inputs** – SeaGauge-Remote will support up to 12 analog inputs for interface to most temperature, pressure, and voltage senders. Internal signal conditioning allows resistive senders and direct voltage inputs up to 36 volts on selected inputs. Most temperature and pressure senders use variable resistance to convert physical parameters into an analog voltage. SeaGauge-Remote provides a 2.5 volts reference and proper pull-up resistance to interface with these senders.

To accommodate more accurate measurements, SeaGauge-Remote also supplies +5 volt output to drive specified senders with require a regulated voltage source commonly found in high precision pressure senders.

**Optional EGT inputs** – SeaGauge-Remote provides an option for built-in interface for up to two K-Type thermocouples commonly used for exhaust gas temperature (EGT) measurements. These probes output a very low level voltage (typically 0 – 0.5v) that need to

## SeaGauge-Remote G2 User's Manual

be amplified and conditioned to obtain reliable results. SeaGauge-Remote EGT option provides the proper conditioning and calibration to attach K-Type EGT probes directly to the unit. When not configured for EGT input, A10 and A11 are set for conventional analog sensors

**Pulse Inputs** - SeaGauge-Remote can accept up to three pulse inputs from a variety of sources for measurement of revolution information such as tachometer and speedometer functions. SeaGauge-Remote conditions pulse inputs to allow direct interface to most tachometer signal generators. SeaGauge-Remote also provides pulse dividers up 256 ratio for interface to inductive pickup systems.

**Alarm Output** – SeaGauge-Remote can be configured to support high/low alarm conditions on each of the 12 analog inputs and 3 pulse inputs. User specified alarm settings are combined into a single output used to drive visual or audio indicators such as a buzzer or panel lamp.

**Indicator Port** – 12-pin digital connector for attaching a vSwitch 12-channel Relay module or 12 input indicator module. Switch activation commands are passed through from either Port to control state of relays or provide ON/OFF status from indicators. Indicator status use voltage dividers to convert analog voltage from 12V down to 2.5V. **Do not connect voltage greater than 15VDC directly to port or immediate damage will result..**

**Serial Interface** – dual built-in RS232 serial ports are provided for driving optional remote displays, NMEA 2000 adapter, or PC serial port. A Bluetooth and WiFi module is also available for wireless interface to PC and PDA devices.

**Slave USB interface** – SeaGauge-Remote contains a slave USB 2.0 interfaces for connection to PC/Laptop. The USB interface is shared with the serial port and only is active on a select port at a time. Miniature switches are used to select RS232 Serial or USB mode for each port.

**ENET/WiFi Interface** – SeaGauge-Remote has an option to support interface to Ethernet (10/100) via RJ45 or WiFi (802.11 b/g). Data is transmitted in SeaSmart PushSmart protocol to embedded Web Server or via UDP/TCP over network connections. Micro SD memory card slot provides data logging and configuration via XML files stored on SD memory card

**NOTE: Only SeaGauge G2 with ENET or WiFi option supports data logging to SD Memory.**

# What You Get

## Unit

SeaGauge-Remote unit with power and sensor input. Unit constantly monitors the sensor inputs and creates NMEA 0183 compatible sentences two times per second. A 10-bit analog converter samples sensor data and then performs a real-time average. The built-in microprocessor takes the averaged value for each sensor and looks up the display value from a 256 point table that is user modifiable. Once a sensor value is determined, it is paired with a corresponding text label and sent via built-in serial port in NMEA 0183 format or optional NMEA 2000 interface. Sensor data is also compared with a user defined min/max alarm table and will trigger an alarm signal if any of the parameters are exceeded.

## Cables

SeaGauge-Remote is supplied with Deutsch plugs for attaching sensor and power inputs to the unit. Supplied USB and RS232 cables are used for attachment to remote PC or display heads..

## SeaGauge

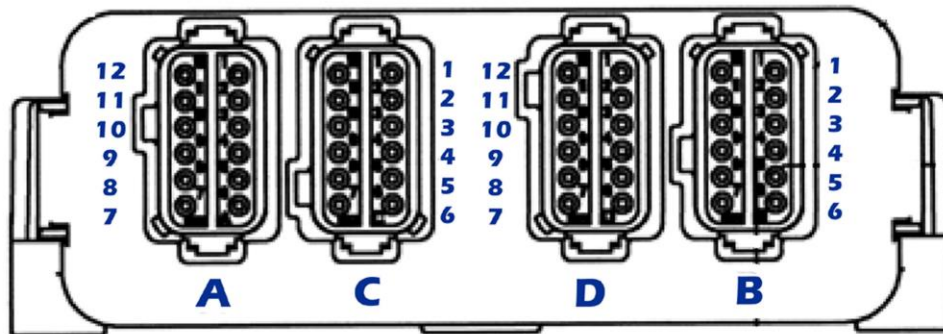

netGauges - A (gray)

12=Status 1	1=Status 6
11=Status 0	2=Status 7
10=Status 2	3=Status 5
9= Status 3	4=Status 4
8= Status 8	5=Status 11
7=Status 9	6=Status 10



netGauges - C (green)

12=VOLT 1	1=VOLT 0
11=LEVEL 1	2=LEVEL 0
10=TEMP 1	3=TEMP 0
9=PSI 1	4=PSI 0
8=PSI 3	5=PSI 2
7=TEMP 3	6=TEMP 2



netGauges - D (brown)

12=PULSE1	1=PULSE0
11=GROUND	2=GROUND
10=PULSE2	3=ALARM
9=---	4=---
8=---	5=---
7=---	6=---



netGauges - B (black)

12=Ground	1=Ground
11=12-24VDC	2=12-24VDC
10=---	3=---
9=---	4=---
8=---	5=---
7=---	6=---

# SeaGauge-Remote G2 User's Manual

# Operation

---

SeaGauge-Remote is sealed and self-contained. All user control is performed via the built-in USB or RS232 ports. The unit can be configured with the included vDash utility described in a separate manual or via text commands sent directly to the serial port.

When you receive your unit it has been programmed with default sensor calibration tables and labels. All alarms have been cleared. The unit can be reconfigured by modification of the tables using a text editor and reloading the unit.

To prevent any errors in programming – it is recommended to use the included vDash utility for reprogramming of the unit. While it is possible to manually reconfigure the tables using standard serial communications utilities – any errors could render the unit inoperable and require reprogramming of the entire unit using the separate flash programming port.

## Sensor Inputs

The factory default inputs include 4 temperature, 4 pressure, 2 voltage, 2 Fuel, and 3 pulse inputs. The following table describes the default sensor ranges and display labels

<i>Pin</i>	<i>Channel</i>	<i>Function</i>	<i>Min Value</i>	<i>Max Value</i>	<i>Min Alarm</i>	<i>Max Alarm</i>
<i>C3</i>	<i>A0</i>	<i>TEMP1</i>	<i>-19 F</i>	<i>336 F</i>	<i>OFF</i>	<i>OFF</i>
<i>C10</i>	<i>A2</i>	<i>TEMP2</i>	<i>-19 F</i>	<i>336 F</i>	<i>OFF</i>	<i>OFF</i>
<i>C6</i>	<i>A5</i>	<i>TEMP3</i>	<i>-19 F</i>	<i>336 F</i>	<i>OFF</i>	<i>OFF</i>
<i>C7</i>	<i>A6</i>	<i>TEMP4</i>	<i>-19 F</i>	<i>336 F</i>	<i>OFF</i>	<i>OFF</i>
<i>C1</i>	<i>A8</i>	<i>VOLT1</i>	<i>0</i>	<i>28V</i>	<i>OFF</i>	<i>OFF</i>
<i>C5</i>	<i>A4</i>	<i>PSI1</i>	<i>0</i>	<i>150</i>	<i>OFF</i>	<i>OFF</i>
<i>C8</i>	<i>A7</i>	<i>PSI2</i>	<i>0</i>	<i>150</i>	<i>OFF</i>	<i>OFF</i>
<i>C4</i>	<i>A5</i>	<i>PSI3</i>	<i>0</i>	<i>150</i>	<i>OFF</i>	<i>OFF</i>
<i>C9</i>	<i>A6</i>	<i>PSI4</i>	<i>0</i>	<i>150</i>	<i>OFF</i>	<i>OFF</i>
<i>C12</i>	<i>A11</i>	<i>VOLT2</i>	<i>0</i>	<i>28</i>	<i>OFF</i>	<i>OFF</i>
<i>C2</i>	<i>A9</i>	<i>Fuel1</i>	<i>0</i>	<i>100%</i>	<i>OFF</i>	<i>OFF</i>
<i>C11</i>	<i>A10</i>	<i>Fuel2</i>	<i>0</i>	<i>100%</i>	<i>OFF</i>	<i>OFF</i>
<i>D1</i>	<i>P0</i>	<i>PULSE0</i>	<i>25</i>	<i>10000</i>	<i>OFF</i>	<i>OFF</i>
<i>D12</i>	<i>P1</i>	<i>PULSE1</i>	<i>25</i>	<i>10000</i>	<i>OFF</i>	<i>OFF</i>
<i>D10</i>	<i>P2</i>	<i>PULSE2</i>	<i>25</i>	<i>10000</i>	<i>OFF</i>	<i>OFF</i>

Other sensors can be used by changing any of the 12 calibration tables and 16 display labels. Dip switches allow sensor inputs to be configured for different sensor types to accommodate a wide range of configurations.

## SeaGauge-Remote G2 User's Manual

### Data Output format

After the unit is properly installed and powered up, it will automatically start transmitting data in NMEA 0183 format with an update rate of 1 per second for each of 16 inputs (12 analog and 3 pulse). The following is an example of a typical sequence.

```
$PCDIS,SEAGAUGE-REMOTE,0001.100,*79
$IIXDR,G, 0 ,B,OIL **1*37
$IIXDR,G, 192 ,C,ENGINE**2*48
$IIXDR,G, 35 ,D,TRANS **3*26
$IIXDR,G, 8.2,E,VOLT ***4*45
$IIXDR,G, 60,F,AMPS ***5*4B
$IIXDR,G, 57 ,G,PORT ***6*5E
$IIXDR,G, 57 ,H,STRB ***7*5C
$IIXDR,G, 72,I,FUEL****8*47
$IIXDR,G, 00 ,A,RPM ****0*24
```

The \$IIXDR NMEA 0183 sentence contains 6 fields separated by commas with the following definitions:

- 1) \$IIXDR – Instrumentation data tag
- 2) Data type specifier – from NMEA tag lookup table
- 3) Data Values – from calibration lookup table
- 4) Unit of measure – from NMEA suffix lookup table
- 5) Instrument Label – from device label lookup table
- 6) Checksum

SeaGauge-Remote also add a propriety tag (\$PCDIS) that specifies status information. In this case it specifies the name of the unit and firmware revision number.

## SeaGauge-Remote G2 User's Manual

### Display Label Table

The display labels are obtained from a lookup table. An example table is shown as follows:

```
1) [TABLE] [6800] [8] [64]
2) db 'P TEMP ' ; 0
3) db 'S TEMP ' ; 1
4) db 'P FUEL ' ; 2
5) db 'S FUEL ' ; 3
6) db 'P VOLT ' ; 4
7) db 'P OIL ' ; 5
8) db 'S OIL ' ; 6
9) db 'P BOOST ' ; 7
10) db 'S BOOST ' ; 8
11) db 'S VOLT ' ; 9
12) db 'P EGT ' ; 10
13) db 'S EGT ' ; 11
14) db 'WIND SPD' ; 12
15) db 'SPEED ' ; 13
16) db 'S RPM ' ; 14
17) db 'P RPM ' ; 15
18) db 'GPS ' ; 16
19) db 'SONAR ' ; 17
20) db 'NAV LGHT' ; 18
21) db 'BILGE ' ; 19
22) db 'CABIN P ' ; 20
23) db 'CABIN S ' ; 21
24) db 'SPOT P ' ; 22
25) db 'SPOT S ' ; 23
26) db 'SHOWER ' ; 24
27) db 'ANCHOR ' ; 25
28) db 'P START ' ; 26
29) db 'S START ' ; 27
30) db 'W TANK 2' ; 28
31) db 'SET ' ; 29
32) db '0001.097' ; 30
33) db 'SEAGAUGE' ; 31
```

There are 33 rows in the table. Each row except for the first corresponds to a label attached to a sensor input and used to format the NMEA 0183 data output sentence.

The first row identifies the file as a table specifier ([TABLE]) followed by the starting address in memory to load the table ([6800]), followed the length in characters contained on each row ([8]) followed by the number of rows ([50]). None of the values in the first row can be modified.

The following 16 rows contain the text labels used for each sensor and 16 rows for vSwitch labels. Each text label must start with “db ” and end with “;”. This can not be modified. Each label must contain exactly 8 characters. If you wish to have shorter labels then use the “\*” character as a placeholder but be sure there are exactly 8 characters per label. Anything after the “;” character is considered a comment and ignored.

Rows 31 – 33 are reserved and should not be modified.

# SeaGauge-Remote G2 User's Manual

## Channels Table

The 12 sensor input are assigned to calibration tables via the Channels Table. This table allows mapping of analog inputs to desired lookup tables. Calibration tables are assigned in the same order as the Display Label Table entries. So for example – the OIL label is assigned to the first calibration table and the ENGINE the second and so on. The Channels table decides which analog input pin is actually the OIL input.

An example table is as follows:

```
[TABLE][7800][1][512]
```

db %00; Channels	00	32
db %04; Channels	01	33
db %06; Channels	02	34
db %03; Channels	03	35
db %0A; Channels	04	36
db %01; Channels	05	37
db %05; Channels	06	38
db %07; Channels	07	39
db %02; Channels	08	40
db %0B; Channels	09	41
db %08; Channels	10	42
db %09; Channels	11	43
db %0C; Channels	12	44
db %0D; Channels	13	45
db %0E; Channels	14	46
db %0F; Channels	15	47

The first row identifies the file as a table specifier ([TABLE]) followed by the starting address in memory to load the table ([7800]), followed the length in bytes contained on each row ([1]) followed by the number of rows ([32]). None of the values in the first row can be modified.

Rows 2-17 contain two digit hexadecimal values corresponding to the analog channel assigned to the display label and calibration table. For example row 2 contains the value 01 HEX which corresponds to channel A1 which is pin 3 on the 9-pin data connector. Row 3 contains the value 04 HEX which is channel 4 and pin 5 on the connector and so on.



# SeaGauge-Remote G2 User's Manual

## Alarms Tables

The Alarms table is used to set min and max alarm thresholds for each of the 8 sensor inputs. After the analog conversion and digital averaging, the 10 bit vales are scaled to 8-bit values and used to perform a lookup of actual display values from the Calibration tables. 8-bit digital values have a range from 0 to 255. Every sensor input is scaled to this range. Min alarms are defined as being tripped when the scaled sensor value is below the min set point. Max alarms are defined as being tripped when the scaled sensor value is above the max set point.

```
1)      [TABLE] [7800] [1] [128]
2)      db %20,      ;"OIL      " ;0
3)      db %FF,
4)      db %00,      ;"ENGINE  " ;1
5)      db %E0,
6)      db %00,      ;"TRANS  " ;2
7)      db %FF,
8)      db %00,      ;"VOLT   " ;3
9)      db %FF,
10)     db %00,      ;"AMPS   " ;4
11)     db %FF,
12)     db %00,      ;"PORT   " ;5
13)     db %FF,
14)     db %00,      ;"STRB   " ;6
15)     db %FF,
16)     db %00,      ;"FUEL   " ;7
17)     db %FF,
18)     db %00,      ;"ALARM  " ;8
19)     db %FF,
20)     db %00,      ;"ALARM  " ;9
21)     db %FF,
22)     db %00,      ;"ALARM  " ;A
23)     db %FF,
24)     db %00,      ;"ALARM  " ;B
25)     db %FF,
26)     db %00,      ;"ALARM  " ;C
27)     db %FF,
28)     db %00,      ;"ALARM  " ;D
29)     db %FF,
30)     db %00,      ;"ALARM  " ;E
31)     db %FF,
32)     db %00,      ;"ALARM  " ;F
33)     db %FF,
```

The first row identifies the file as a table specifier ([TABLE]) followed by the starting address in memory to load the table ([7800]), followed the length in bytes contained on each row ([1]) followed by the number of rows ([128]). None of the values in the first row can be modified.

The following 16 rows contain the alarm value pairs used for each sensor. Each alarm value must start with “db ” and end with “;”. This can not be modified. Each label must contain exactly 1 hex byte starting with a “%” symbol and followed by two hexadecimal characters. In hexadecimal notation %FF is equal to 255 decimal. Anything after the “;” character is considered a comment and ignored.

## SeaGauge-Remote G2 User's Manual

Alarm values are entered in pairs with the first value being the min alarm threshold and the second being the max threshold. If the min threshold is set to %00, then the min alarm is disabled since no sensor value can be less than 0. If the max threshold is set to %FF, then the max alarm is disabled since no sensor value can be greater than 255. In this way, various min and max alarms can be disabled.

In this example row 2 contains the hexadecimal value %20 which translates to 32 decimal. This value is associated with the 32ed row of the OIL pressure lookup table and indicates the min OIL pressure alarm will sound if the scaled sensor value drops below 32ed row. If the 32ed row in the OIL Pressure calibration table corresponds to the display value of 10 PSI then the alarm will sound when pressure drops below 10 PSI. Since the max alarm (row 3) is set to %FF (255 decimal) the max alarm is disabled. In other words, the values used in the Alarm Table are row indexes in the matching Calibration tables used to trigger alarm events.

# SeaGauge-Remote G2 User's Manual

## Calibration Tables

The SeaGauge-Remote contains 12 calibration tables used to convert sensor input to display values. Sensor inputs are averaged, scaled, and converted to digital values with a range from 0 to 255 decimal. These values are then used to look up 8 character values from a 256 row calibration table. As a result, SeaGauge-Remote can be easily configured to adapt to virtually any type of sensor input and adjusted to precisely match sender profiles.

The calibration table must conform to a strict format to be loaded. The first row of the text file must start with "[TABLE] [Table Address] [Num of Characters per line = 8] [Number of lines = 256]" to indicate to the download program it is a text file. The remaining 256 lines are the display lookup values corresponding to each of 256 table indexes. No extra spaces or other symbols can be inserted as the file is parsed by position.

Following is an example of a partial table used to display battery voltage. The actual table has 256 indexed values.

0	1	2	3	4	5	6	7	8	9	10	11	12	13	14	15	16	17	18	19	20	17	
[	T	A	B	L	E	]	[	C	0	0	0	]	[	8	]	[	2	5	6	]		
d	b	'		0	.	0	0	1	0	0	'	;	0	0	0							
d	b	'		0	.	1	0	1	0	0	'	;	0	0	1							
d	b	'		0	.	1	0	1	0	0	'	;	0	0	2							
d	b	'		0	.	2	0	1	0	0	'	;	0	0	3							
d	b	'		0	.	3	0	2	0	1	'	;	0	0	4							
d	b	'		0	.	3	0	2	0	1	'	;	0	0	5							
d	b	'		0	.	4	0	3	0	1	'	;	0	0	6							
d	b	'		0	.	5	0	3	0	1	'	;	0	0	7							
d	b	'		0	.	5	0	3	0	2	'	;	0	0	8							
d	b	'		0	.	6	0	4	0	2	'	;	0	0	9							
d	b	'		0	.	7	0	4	0	2	'	;	0	1	0							
d	b	'		0	.	7	0	4	0	2	'	;	0	1	1							
d	b	'		0	.	8	0	5	0	3	'	;	0	1	2							
d	b	'		0	.	9	0	6	0	3	'	;	0	1	3							
d	b	'		0	.	9	0	6	0	3	'	;	0	1	4							
d	b	'		1	.	0	0	6	0	3	'	;	0	1	5							
d	b	'		1	.	1	0	7	0	4	'	;	0	1	6							
d	b	'		1	.	1	0	7	0	4	'	;	0	1	7							

- Column 0-3 must be "db '" to indicate start of data field
- Column 4-7 is the 6 character display value associated with the table index
- Column 8-9 is two character (HEX) used for NMEA 2000 lookup
- Column 10-11 is two character (HEX) used for graphic display lookup
- Column 12-13 must be ";" to indicate end of display values

## SeaGauge-Remote G2 User's Manual

- Column 14 – is a comment and usually is the table row index number for reference

The 4 character display value can be any alpha-numeric value but usually is a numeric sequence representing the desired readout for the given table index.

The 2 character HEX NMEA 2000 Display Lookup value is used to calibrate the data used to generate NMEA 2000 PGNs.

The 2 character HEX Graphic Display Lookup value is used to calibrate the graphic displays. The values range for 0x00 Hex to 0xFF Hex (255 decimal) were 0xFF represents the maximum range for the graphic display. Normally these values can increase in a linear fashion from 0x00 to 0xFF. However, they can be adjusted in a non-linear sequence to give graphic displays more resolution in a desired operating range. For example if it is desired to have more sensitivity at vehicle operating temperature of 180 F, these values can be adjusted so graphic displays ramp quickly and then level off.

Less sensitive graphic display	More sensitive graphic display
db ' 553E20' ; 164	db ' 553E31' ; 229
db ' 604320' ; 165	db ' 604332' ; 230
db ' 654720' ; 166	db ' 654733' ; 231
db ' 704B20' ; 167	db ' 704B34' ; 232
db ' 755021' ; 168	db ' 755035' ; 233
db ' 805421' ; 169	db ' 805436' ; 234
db ' 855821' ; 170	db ' 855837' ; 235
db ' 905D21' ; 171	db ' 905D38' ; 236
db ' 956122' ; 172	db ' 956139' ; 237
db 1006522' ; 173	db ' 100653A' ; 238
db ' 1056A22' ; 174	db ' 1056A3B' ; 239
db ' 1106E22' ; 175	db ' 1106E3C' ; 240

Each table has 2048 characters to modify and there are 88 choices for each character for a total of over 18,000 character choices for each table. For this reason the tables are much too large to be modified directly from the Setup Mode. However table files can be obtained and downloaded to the unit to allow for modification of any table. All that is needed is a computer interface (RS232 or Bluetooth) and a communication program such as HyperTerminal or the vDash utility.

Contact Checto Digital Instruments or <http://www.chetcodigital.com/SeaGauge/support.htm> for more information on obtaining additional table files to match particular senders/sensors.

# SeaGauge-Remote G2 User's Manual

## OPTIONS Table

SeaGauge-Remote has many functions which are configured via the OPTIONS table. All operating parameters can be modified using the vDash utility and are provided here only for informational purposes. Please consult the vDash users manual for more detail on user modification.

[TABLE][7800][1][512]	
db %02; NumOfPages	00
db %00; NumNMEAPages	01
db %01; NumControlPages	02
db %0C; AnalogInputs	03
db %00; NMEAInputs	04
db %40; Demo Mode	05
db %0B; DisplayType	06
db %3C; Contrase	07
db %14; P0Scale	08
db %32; P0Time	09
db %01; Pulse0Enable	10
db %00; P0Edge	11
db %14; P1Scale	12
db %32; P1Time	13
db %01; Pulse1Enable	14
db %00; P1Edge	15
db %03; SerialDataInMode	16
db %00; SerialDataOutMode	17
db %00; NotUsed	18
db %14; BaudRate	19
db %00; SerialCommandMode	20
db %00; SerialCommandMode	21
db %00; MasterSlave	22
db %8C; NumOfvSwitch	23
db %01; AlarmEnable	24
db %00; AlarmMode	25
db %00; Invert Display	26
db %56; Backlight Init	27
db %04; Scroll Button	28
db %02; Set Button	29
db %78; Pulse0 Dial Scale facor	30
db %78; Pulse1 Dial Scale facor	31
db %00;OPTIONS USB AUTODET	192
db %02;OPTIONS USB 1 ENABLE	193
db %3A;OPTIONS USB 2 ENABLE	194
db %00;OPTIONS USB STATUS	195
db %01;OPTIONS PORT0DISPLAY	196
db %02;OPTIONS PORT1DISPLAY	197
db %04;OPTIONS USB BAUDRATE	198
db %01;OPTIONS DISPLAY SYNC	199
db %C8;OPTIONS RPM2 SCALE	200
db %14;OPTIONS RPM2 TIME	201
db %00;OPTIONS RPM2 ENABLE	202
db %02;OPTIONS RPM2 EDGE	203
db %78;OPTIONS P2 DIAL SCAL	204

## SeaGauge-Remote G2 User's Manual

db %00;OPTIONS STAT ENABLE		205
db %01;OPTIONS Not Used		206
db %00;OPTIONS Not Used		207
db %01;OPTIONS TIMER0ENABLE		208
db %01;OPTIONS TIMER1ENABLE		209
db %01;OPTIONS TIMER2ENABLE		210
db %00;OPTIONS TIMER3ENABLE		211
db %00;OPTIONS TIMER0 HB		212
db %01;OPTIONS TIMER0 LB		213
db %00;OPTIONS TIMER1 HB		214
db %01;OPTIONS TIMER1 LB		215
db %00;OPTIONS TIMER2 HB		216
db %01;OPTIONS TIMER2 LB		217
db %FF;OPTIONS TIMER3 HB		218
db %00;OPTIONS TIMER3 LB		219
db %00;OPTIONS BASE TIMMER		220
db %00;OPTIONS Update Rate		221
db %FF;OPTIONS LCD TEMP ADJ		222
db %20;N2K PGN INDEX	00	256
db %00;N2K PARAMS INDEX	00	257
db %21;N2K PGN INDEX	01	258
db %00;N2K PARAMS INDEX	01	259
db %40;N2K PGN INDEX	02	260
db %00;N2K PARAMS INDEX	02	261
db %41;N2K PGN INDEX	03	262
db %00;N2K PARAMS INDEX	03	263
db %30;N2K PGN INDEX	04	264
db %00;N2K PARAMS INDEX	04	265
db %20;N2K PGN INDEX	05	266
db %01;N2K PARAMS INDEX	05	267
db %21;N2K PGN INDEX	06	268
db %01;N2K PARAMS INDEX	06	269
db %50;N2K PGN INDEX	07	270
db %00;N2K PARAMS INDEX	07	271
db %51;N2K PGN INDEX	08	272
db %00;N2K PARAMS INDEX	08	273
db %31;N2K PGN INDEX	09	274
db %00;N2K PARAMS INDEX	09	275
db %C0;N2K PGN INDEX	10	276
db %00;N2K PARAMS INDEX	10	277
db %C1;N2K PGN INDEX	11	278
db %00;N2K PARAMS INDEX	11	279
db %00;N2K PGN INDEX	12	280
db %00;N2K PARAMS INDEX	12	281
db %00;N2K PGN INDEX	13	282
db %00;N2K PARAMS INDEX	13	283
db %11;N2K PGN INDEX	14	284
db %00;N2K PARAMS INDEX	14	285
db %10;N2K PGN INDEX	15	286
db %00;N2K PARAMS INDEX	15	287

## Connectors

---

The SeaGauge-Remote unit has four Deutsch terminal blocks for attachment of power, pulse, sensor and indicator inputs. Each 12 pin plug is keyed with locking tabs for reliable connection. The individual crimp style pins accept up to 18 gauge wire and can be inserted without tools.

The two rear connectors provide for NMEA 2000/J1939 CAN Bus and USB/Serial ports.

NMEA 2000/J1939 use the 5-pin M12 connector. Indicator LED show CAN Bus activity for transmit and receive and both flash about 1 per second.

Direct attachment to PC USB ports requires a pair of custom USB cables (provided) which mate with the 8 pin connector. The White USB cable is used for normal calibration programming with vDash and the Black USB cable is used only for special firmware updates of the CAN Bus interface

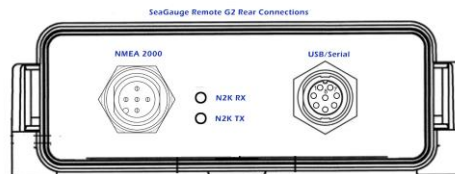

# SeaGauge-Remote G2 User's Manual





## SeaGauge-Remote G2 User's Manual

### System Power

System power is supplied via the 12-pin B plug (black). The block also provides the reference voltage used for some sensors and the optional Ethernet cable plug.

<i>POWER Plug B (black)</i>				
<i>Pin</i>	<b>FUSE</b>	<b>Function</b>	<b>Direction</b>	<b>Volt</b>
<i>P1</i>	-	Ground	IN	0
<i>P12</i>	-	Ground	IN	0
<i>P2</i>	2 AMP	12 Volt Input power	IN	9-24
<i>P11</i>	2 AMP	12 Volt Input power	IN	9-24
<i>P3</i>	-	-	IN	-
<i>P10</i>	-	-	IN	-
<i>P4</i>	-	5 Volt Output @ 500 mA	OUT	5
<i>P9</i>	-	5 Volt Output @ 500 mA	OUT	5
<i>P5</i>	-	ENET TX + (optional module)	OUT	0-5
<i>P8</i>	-	ENET RX + (optional module)	IN	0-5
<i>P6</i>	-	ENET TX - (optional module)	OUT	0-5
<i>P7</i>	-	ENET RX - (optional module)	IN	0-5

The Power wire is connected to battery (+12 volts) via a switched 2 Amp fuse circuit. Never connect directly without providing a fused circuit. Circuit should be powered when other instrumentation and NMEA equipment is powered. NMEA 2000 requires separate 12VDC bus power for network cable. SeaGauge is not powered by NMEA 2000 interface.

The ground wire should be connected to a solid ground bus located near the unit. The case is not grounded. Be sure to connect the ground wire from the cable and never rely on the case for ground. All SeaGauge grounds are tied together internally. Be sure you have a solid ground from SeaGauge back to all sensors.

## SeaGauge-Remote G2 User's Manual

### Pulse Inputs

<i>Pulse Plug D (brown)</i>				
<i>Pin</i>	FUSE	Function	Direction	Volt
<i>P1</i>	-	Pulse 0	IN	0-12VDC
<i>P12</i>	-	Pulse 1	IN	0-12VDC
<i>P2</i>	-	Ground	IN	0
<i>P11</i>	-	Ground	IN	0
<i>P3</i>	-	Alarm	OUT	5VDC
<i>P10</i>	-	Pulse 2	IN	-
<i>P4</i>	-	EGT 1 +(yellow) ) (optional)	IN	1VAC
<i>P9</i>	-	EGT 1 – (red) ) (optional)	IN	1VAC
<i>P5</i>	-	EGT 2 – (yellow) ) (optional)	IN	1VAC
<i>P8</i>	-	EGT + (red) (optional)	IN	1VAC
<i>P6</i>	-	Ground	IN/Out	0
<i>P7</i>	-	Ground	IN/Out	0

The Pulse signals are used for RPM or other rotational senders that output a pulse stream of 12 volts maximum. The circuit is normally connected to the tach output of the ignition system to calculate RPM but can be used for other senders.

The Alarm output is set by internal jumper – Default to drive a Pizo-electric alarm or buzzer directly at 5VDC (20mA max). When external alarm is enabled, the buzzer will sound

The alarm signal can also provide the ground for a relay to drive an alarm or buzzer. The hot lead of the alarm is connected via fuse to power source and ground connected directly to alarm signal. The alarm should draw no more than 25 mA. Never connect the alarm without a fuse.

The optional EGT inputs provide for directly connecting K-type thermocouple sensors using matching thermocouple wire (yellow/red). Never connect any other sensor to the EGT inputs.

# SeaGauge-Remote G2 User's Manual

## Sensors

The 12 pin sensor plug used to interface with various senders to provide information to the unit. The information supplied in the following table is typical but may be different dependent on your application.

There are two basic classes of senders – those that provide a resistive load to ground and those that provide a voltage.

Senders that provide a resistance to ground (temperature/pressure) are easily interfaced by using a pull-up resistance. This resistance should be set to the mid-range resistance of the selected sender.

Senders that produce a voltage need to limit the full range voltage to no more than 2.5 volts. These senders will require a voltage divider (series/pull-down) to scale the range down to 2.5 volt max. For example – to support a voltage reading of 0-20 volts requires a scale down of  $2.5 / 27 = 0.0925$  Using the voltage divider calculation of  $V_{out} = V_{in} (R_{pd} / (R_{pd} + R_s))$  if we set  $R_{pd}$  to 10K and  $R_s$  to 100K, the resulting divider is  $1/11 = 0.09$ .

The standard SeaGauge-Remote configuration it to provide four temperature sender inputs, two voltage inputs and four pressure inputs.

- **Temperature Inputs** – These inputs are designed to be used with standard coolant senders with a resistance of 1000 ohms at 70 degrees F. Most VDO and GM style senders fit into this range.
- **Sensor Voltage Inputs** – These inputs use a voltage divider ratio of 1/2 and can accept input voltages up to 5.0 volts. Do not connect to a voltage source greater than 12 volts or damage to the unit will result.
- **Battery Voltage Inputs** – These inputs use a voltage divider ratio of 1/11 and can accept input voltages up to 27.5 volts. Do not connect to a voltage source greater than 30 volts or damage to the unit will result.
- **Pressure Inputs** – These inputs are designed to be used with standard oil pressure senders of 0-45 PSI and an resistance range of 0 – 200 ohms. Most VDO and GM style senders fit into this range.
- **EGT Inputs** – These inputs are designed to be used with K-Type thermocouples with a range from 45F to 1650F. If using ungrounded probes, strap the EGT-terminal to ground.

# SeaGauge-Remote G2 User's Manual

The SeaGauge-Remote can be ordered with any combination of Rpu, Rpd, and Rs for each of the twelve sensor inputs that match your application. Contact Chetco Digital Instruments for your custom application.

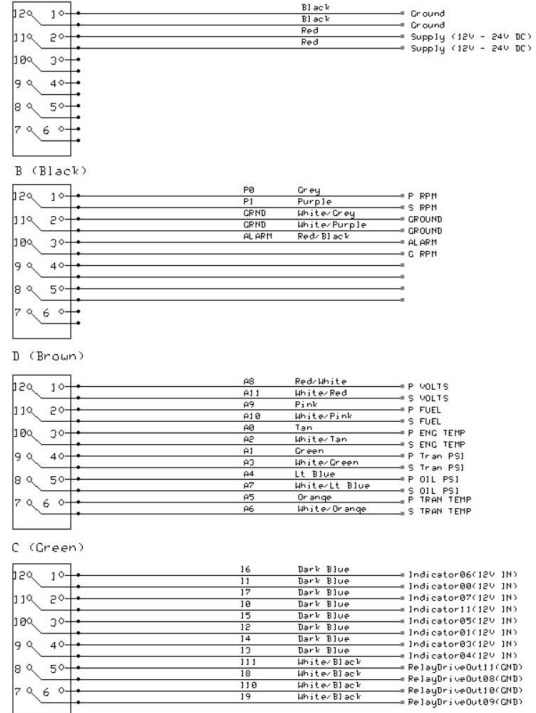
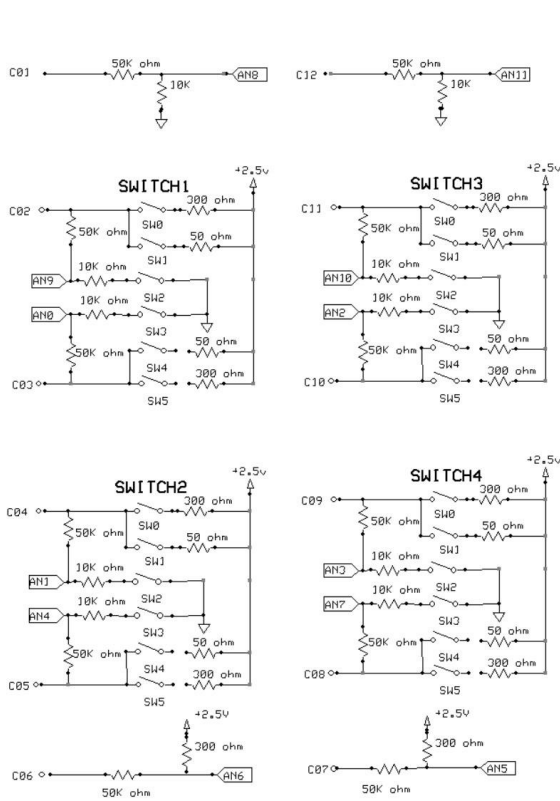

<b>Chetco Digital Instruments</b>		
<b>SeaGauge G2</b>		
Standard Config	Rev 1.3 10/0/18	Page 1

## SeaGauge-Remote G2 User's Manual

Default SeaGauge configuration is to drive external analog sensors directly with no other devices connected to any sensor – Direct Mode.

Do not apply any voltage to sensors configured for Direct Mode. SeaGauge provides a 2.5V reference voltage output to each sensor in Direct Mode which may damage other devices.

<i>Sensor Plug C (green) Direct Mode</i>						
<i>Pin</i>	<i>Channel</i>	<i>Function</i>	<i>Pull-Up <math>\Omega</math></i>	<i>Pull-Down <math>\Omega</math></i>	<i>Series <math>\Omega</math></i>	
<i>P1</i>	A8	Volt 1	-	10K-		100K
<i>P12</i>	A11	Volt 2	-	10K		100K
<i>P2</i>	A9	Fluid 1	300/50*	10K/None*		50K
<i>P11</i>	A10	Fluid 2	300/50*	10K/None*		50K
<i>P3</i>	A0	Temperature 1	300*/50	10K/None*		50K
<i>P10</i>	A2	Temperature 1	300*/50	10K/None*		50K
<i>P4</i>	A1	Pressure 1	300/50*	10K/None*		50K
<i>P9</i>	A3	Pressure 2	300/50*	10K/None*		50K
<i>P5</i>	A4	Pressure 3	300/50*	10K/None*		50K
<i>P8</i>	A7	Pressure 4	300/50*	10K/None*		50K
<i>P6</i>	A5	Temperature 3	300	-		50K
<i>P7</i>	A6	Temperature 4	300	-		50K
<i>* Default Value</i>						

**NOTE – PULL UP RESISTANCE IS CONFIGURED BY ON-BOARD DIP SWITCHES**

**NOTE – PULL DOWN RESISTANCE IS CONFIGURED BY ON-BOARD DIP SWITCHES**

**NOTE – WHEN USING UNGROUNDED EGT PROBES, BE SURE TO STRAP EGT+ TO GROUND. EGT SUPPORT IS AN OPTION ON SEAGAUGE UNITS**

## SeaGauge-Remote G2 User's Manual

### Indicator/Status

Default SeaGauge configuration provides 12 indicator status inputs that detect presence of input voltage > 2VDC. These inputs are mapped to PGN 127501 generated by SeaGauge. If input voltage is > 2VDC the corresponding PGN 127501 bit is set to 1, other wise it is set to 0.

Never apply voltage greater than 15VDC to any of the Indicator/Status inputs.

<i>Indicator Plug A (gray)</i>					
<i>Pin</i>	<i>Channel</i>	<i>Function</i>	<i>Pull-Up Ω</i>	<i>Pull-Down Ω</i>	<i>Series Ω</i>
<i>P1</i>	I6	Indicator Input	-	10K-	50K
<i>P12</i>	I1	Indicator Input	-	10K	50K
<i>P2</i>	I7	Indicator Input	-	10K	50K
<i>P11</i>	I0	Indicator Input	-	10K	50K
<i>P3</i>	I5	Indicator Input	-	10K	50K
<i>P10</i>	I2	Indicator Input	-	10K	50K
<i>P4</i>	I4	Indicator Input	-	10K	50K
<i>P9</i>	I3	Indicator Input	-	10K	50K
<i>P5</i>	I11	Indicator Input	-	10K	50K
<i>P8</i>	I8	Indicator Input	-	10K	50K
<i>P6</i>	I10	Indicator Input	-	10K	50K
<i>P7</i>	I9	Indicator Input	-	10K	50K
<i>* Default Value</i>					

Optional SeaGauge configuration is available to drive 4 external 12VDC relays by grounding the coil. This in only available on the last 4 positions. The remaining 8 operate as normal Indicator/Status inputs

<i>Indicator Plug A (gray) External Relay Drive</i>					
<i>Pin</i>	<i>Channel</i>	<i>Function</i>	<i>Pull-Up Ω</i>	<i>Pull-Down Ω</i>	<i>Series Ω</i>
<i>P1</i>	I6	Indicator Input	-	10K-	50K
<i>P12</i>	I1	Indicator Input	-	10K	50K
<i>P2</i>	I7	Indicator Input	-	10K	50K
<i>P11</i>	I0	Indicator Input	-	10K	50K
<i>P3</i>	I5	Indicator Input	-	10K	50K
<i>P10</i>	I2	Indicator Input	-	10K	50K
<i>P4</i>	I4	Indicator Input	-	10K	50K
<i>P9</i>	I3	Indicator Input	-	10K	50K
<i>P5</i>	I11	Relay Output	-	50 mA sink	-
<i>P8</i>	I8	Relay Output	-	50 mA sink	-
<i>P6</i>	I10	Relay Output	-	50 mA sink	-
<i>P7</i>	I9	Relay Output	-	50 mA sink	-

## SeaGauge-Remote G2 User's Manual

*\* Default Value*

## Sensor Dip Switches

The Sensor inputs can be configured with different combinations of Pull up and Pull down resistance to suit a wide range of possible inputs via a group of Dip Switches.

### Direct Sensor Input

All inputs are pulled up to 2.5V

#### DS3

OFF ON

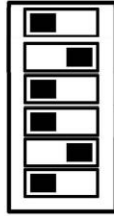

- A10 300 OHM PUP
- A10 50 OHM PUP
- A10 10 K OHM PDOWN
- A2 10 K OHM PDOWN
- A2 300 OHM PUP
- A2 50 OHM PUP

#### DS1

OFF ON

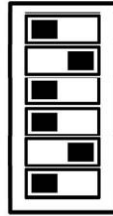

- A9 300 OHM PUP
- A9 50 OHM PUP
- A9 10 K OHM PDOWN
- A0 10 K OHM PDOWN
- A0 300 OHM PUP
- A0 50 OHM PUP

#### DS4

OFF ON



- A3 300 OHM PUP
- A3 50 OHM PUP
- A3 10 K OHM PDOWN
- A7 10 K OHM PDOWN
- A7 300 OHM PUP
- A7 50 OHM PUP

#### DS2

OFF ON

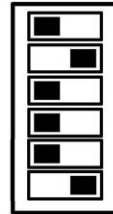

- A1 300 OHM PUP
- A1 50 OHM PUP
- A1 10 K OHM PDOWN
- A4 10 K OHM PDOWN
- A4 300 OHM PUP
- A4 50 OHM PUP

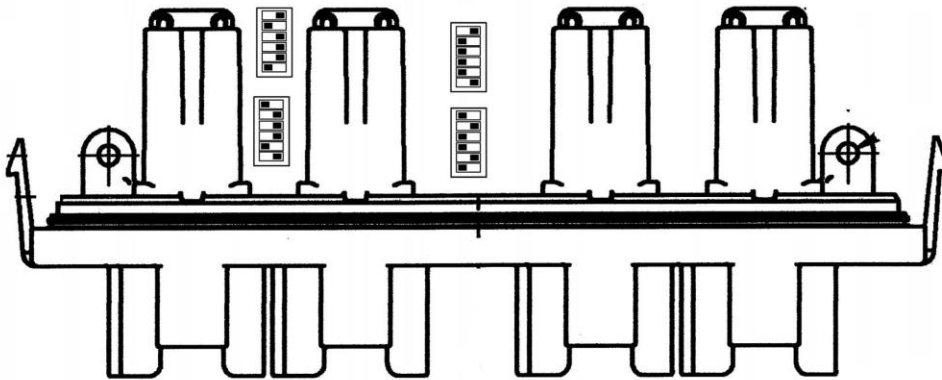

These switches enable/disable a series of pull-up/pull-down resistances to allow for different sensor combinations



# SeaGauge-Remote G2 User's Manual

Typical direct sensor configuration for dual engines and fluid tanks

## Dip Switch

## Function

### DS1

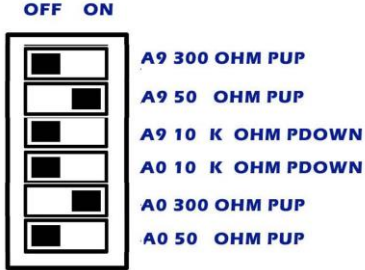

**A9 = 50 OHM PUP (P FLUID)**

**A0 = 300 OHM PUP (P ENG TEMP)**

### DS2

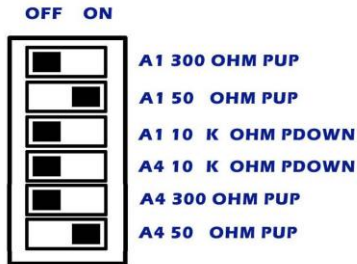

**A1 = 50 OHM PUP (P TRAN PSI)**

**A4 = 50 OHM PUP (P OIL PSI)**

### DS3

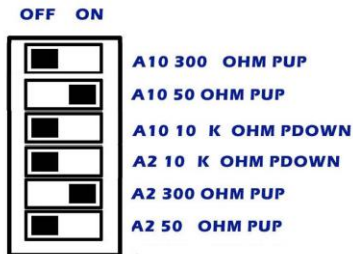

**A10 = 50 OHM PUP (S FLUID)**

**A2 = 300 OHM PUP (S ENG TEMP)**

### DS4

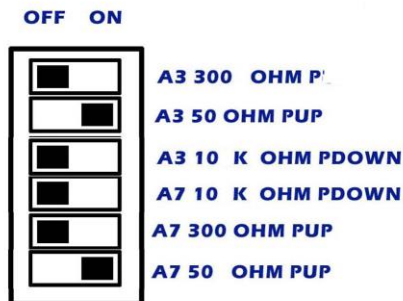

**A3 = 50 OHM PUP (S TRAN PSI)**

**A7 = 50 OHM PUP (S OIL PSI)**

For resistive type of senders such as Temperature, Pressure, and Fuel – use the appropriate Pull-Up resistance to match the operating range of the sender.

# SeaGauge-Remote G2 User's Manual

For Senders that produce a voltage output, disable all pull-ups and enable the Pull-Down resistance to create a voltage divider that limits the max range to 2.5 Volts. For the default 10K Ohm Pull-Down, the limit is 15V max input.

## Voltage Sense Input (parallel)

All inputs measure voltage to 15VDC max

### DS3

OFF ON



- A10 300 OHM PUP
- A10 50 OHM PUP
- A10 10 K OHM PDOWN
- A2 10 K OHM PDOWN
- A2 300 OHM PUP
- A2 50 OHM PUP

### DS1

OFF ON



- A9 300 OHM PUP
- A9 50 OHM PUP
- A9 10 K OHM PDOWN
- A0 10 K OHM PDOWN
- A0 300 OHM PUP
- A0 50 OHM PUP

### DS4

OFF ON

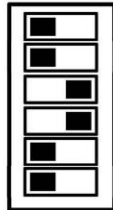

- A3 300 OHM PUP
- A3 50 OHM PUP
- A3 10 K OHM PDOWN
- A7 10 K OHM PDOWN
- A7 300 OHM PUP
- A7 50 OHM PUP

### DS2

OFF ON



- A1 300 OHM PUP
- A1 50 OHM PUP
- A1 10 K OHM PDOWN
- A4 10 K OHM PDOWN
- A4 300 OHM PUP
- A4 50 OHM PUP

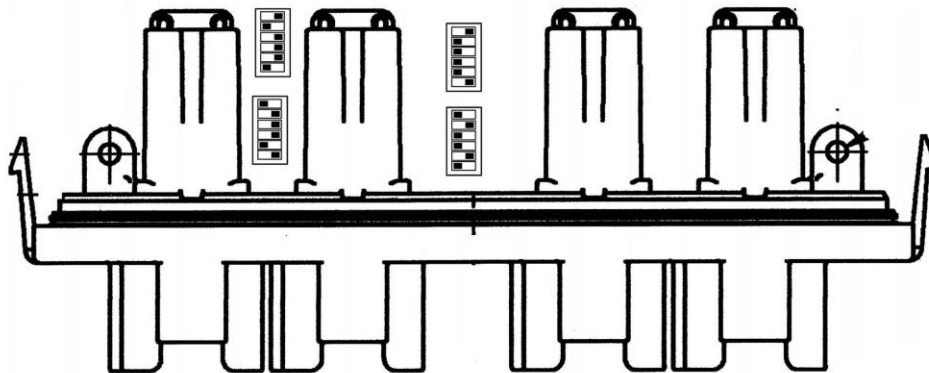

For Senders that output more than 15 Volts, add a series resistance to limit the input to 15V Max. For example, a sender that outputs 10V Max will require a 40K OHM resistor in series to limit the input.

# SeaGauge-Remote G2 User's Manual

## Ports

The serial port connector provides the interface to a computer RS232 interface or SeaGauge display heads. The unit can be remotely controlled via this interface using ASCII command sequences or the optional software utilities. Status information is transmitted out this interface using NMEA 0185 \$IIXDR sentences or NMEA 2000 PGNs. Status information includes current gauge readings and display labels.

Cables are supplied for connection to these interface and there should be no need to interface directly. A serial interface cable is normally used to attach SeaGauge Display Heads. USB cables are used for connection to HOST PC ports. Custom USB cables are required to attach to the 8-pin connectors (provided). White cable is for normal SeaGauge programming using vDash. Black cable is only used for special firmware updates on the NMEA 2000 interface

Default baud rate is 57600, 8 bits, no parity, 1 stop bit, no flow control

<i>Port 0 SERIAL 0/ USB0</i>				
<i>Pin</i>	<i>Color</i>	<i>Function</i>	<i>Direction</i>	<i>Volt</i>
<i>1</i>	Green	USB+	-	-
<i>2</i>	Green/White	Serial TX	OUT	-5 - + 5
<i>3</i>	-	-	-	-5 - + 5
<i>4</i>	Brown	5 Volts	OUT	+ 5
<i>5</i>	-	-	-	-
<i>6</i>	Orange/White	Serial RX	IN	-5 - + 5
<i>7</i>	White	USB-	-	-
<i>8</i>	Orange	Ground	-	-

<i>Port 1 NMEA 2000/CAN BUS J1939</i>				
<i>Pin</i>	<i>Color</i>	<i>Function</i>	<i>Direction</i>	<i>Volt</i>
<i>1</i>	-	Shield	-	-
<i>2</i>	Red	+12VDC	IN	12VDC
<i>3</i>	Black	Ground	IN	0
<i>4</i>	White	CAN H	OUT/IN	+/- 5
<i>5</i>	Blue	CAN L	OUT/IN	+/- 5

The recommended maximum cable length for a USB port without a repeater is 16 feet (3 meters) while a Serial port can drive up 150 feet (50 meters).

Attachment of a USB device more than 16 feet (3 meters) will require a repeater or and USB-to-Serial adapter

## SeaGauge-Remote G2 User's Manual

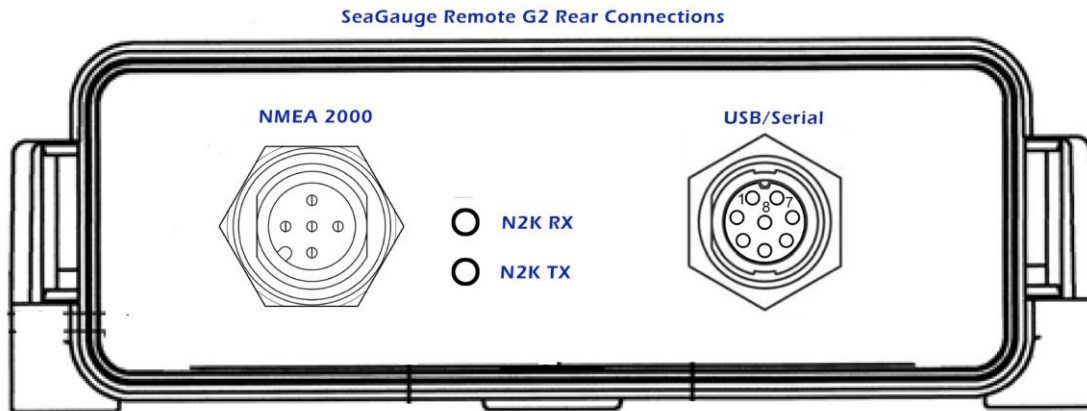

Two port connectors are provided for attachment to remote display heads, Host PC, and NMEA 2000/CAN BUS network. Port functions are configurable via on-board jumpers

**Port 0** is used for attaching a remote display head or to a PC USB port.

This port can be configured for RS232 Serial or USB Slave. The serial mode option is normally used for SeaGauge Display heads as it supports the maximum cable length of 150 feet. A Host PC with built-in serial port can also be used with optional DB9 cable adapter.

Port 0 can also be configured as a USB Slave port and connect directly to a Host PC via optional USB cable adapter **Only one mode can be used at the same time.**

**Port 1** is used for attaching to a NMEA 2000/CAN BUS J1939 network. SeaGauge converts the analog sensor inputs to NMEA 2000 or J1939 PGNs depending on the configuration loaded by the vDash via the USB interface.

The following diagrams show supported modes of operation.

# SeaGauge-Remote G2 User's Manual

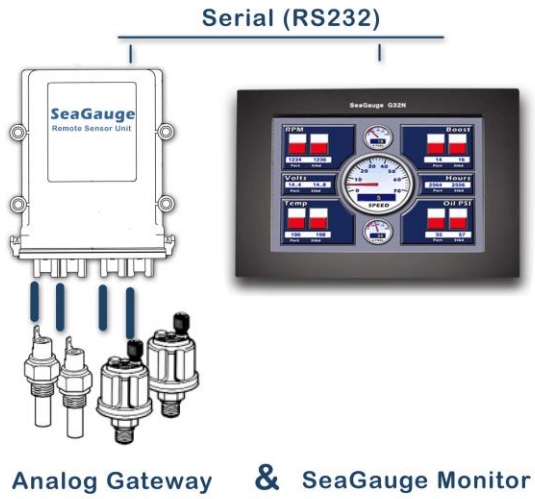

Figure 1 Single SeaGauge Display head via Port 0 in RS232 Serial mode

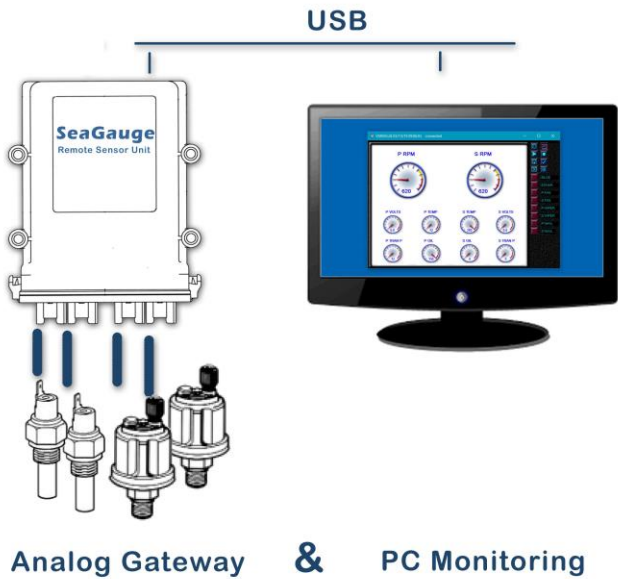

Figure 2 Direct connect to Host PC USB Port

# SeaGauge-Remote G2 User's Manual

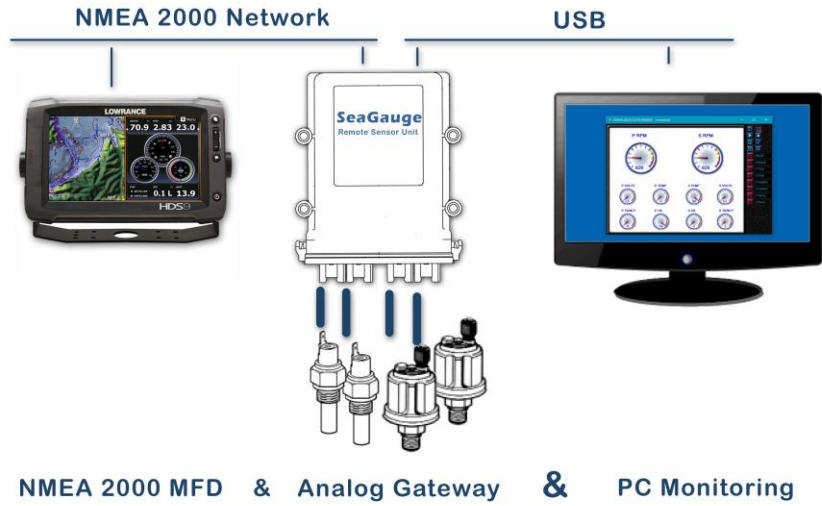

Figure 3 Host PC connection and NMEA 2000/CAN BUS J1939



Figure 4 NMEA 2000/CAN BUS J1939 connection to multiple displays

# SeaGauge-Remote G2 User's Manual

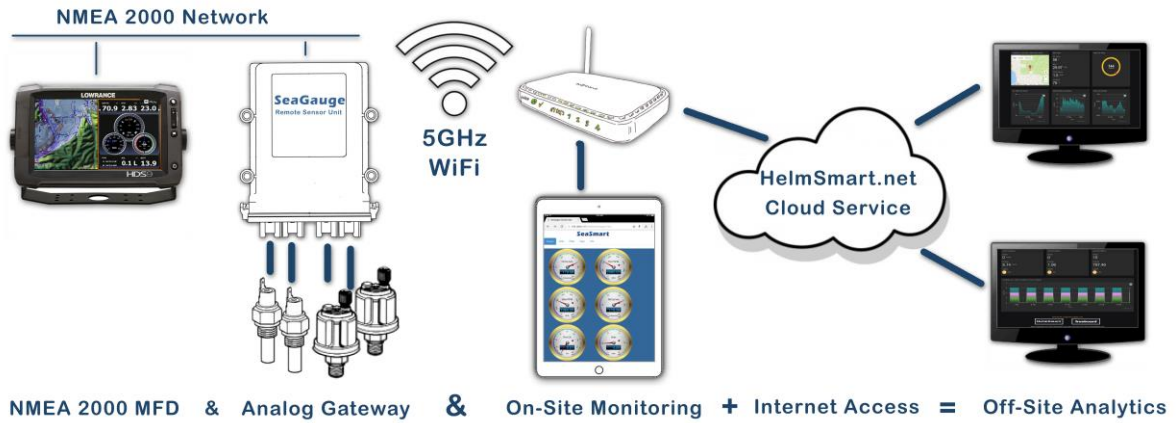

Figure 5 dual SeaGauge as gateway between NMEA 2000 and wireless network (optional WiFi module)

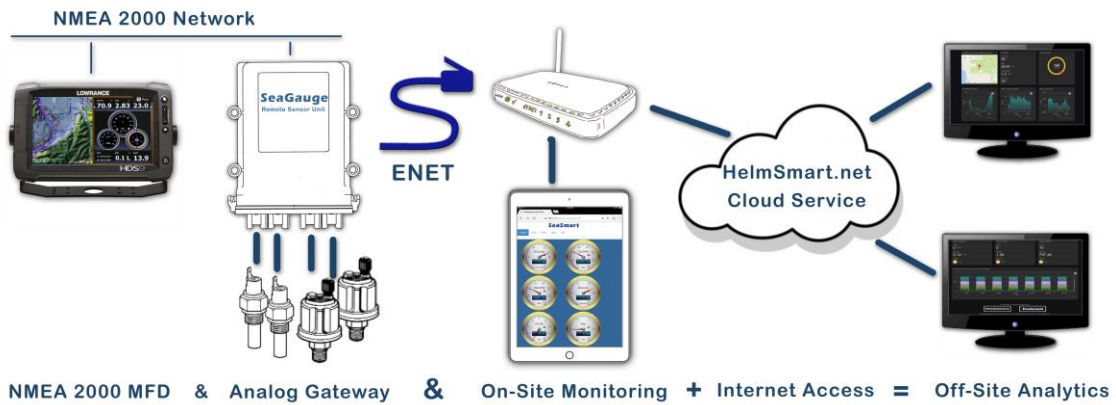
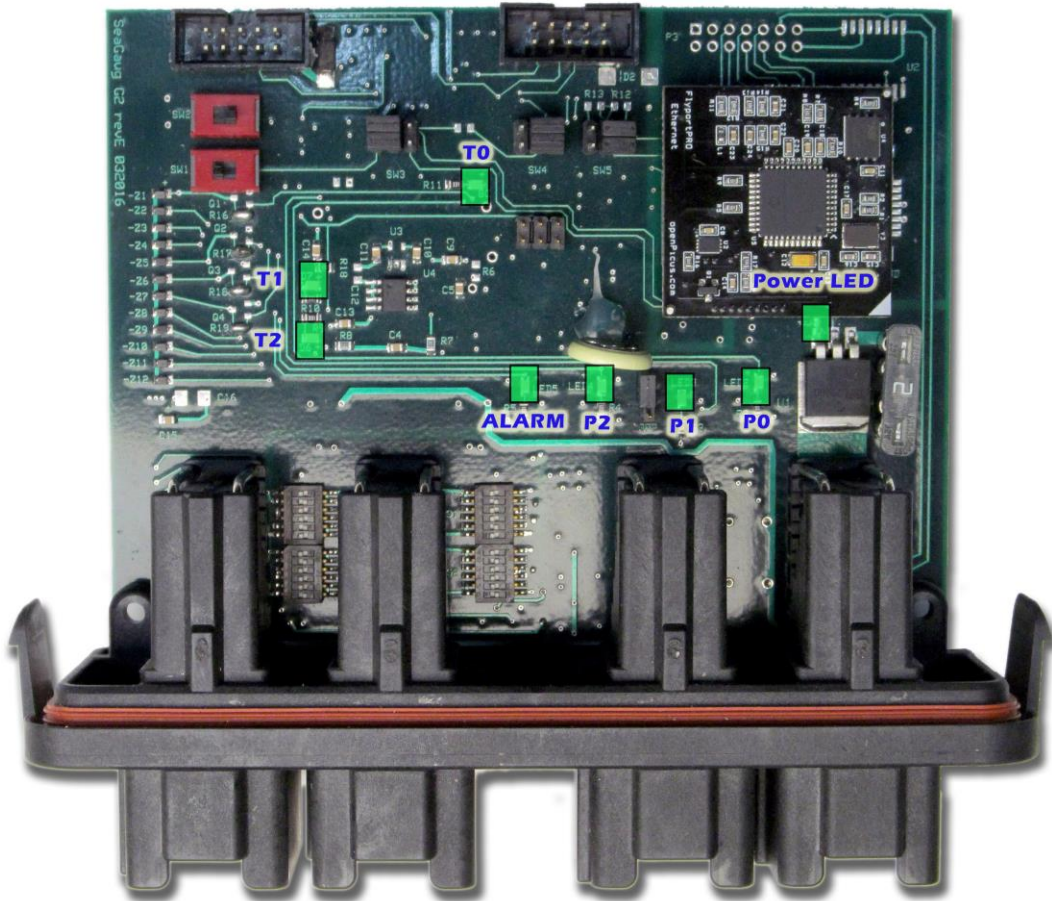

Figure 5 dual SeaGauge as gateway between NMEA 2000 and wireless network (optional Ethernet module)

# SeaGauge-Remote G2 User's Manual

## LED INDICATORS

SeaGauge-Remote has several LED's to indicate operational status of the unit. The following diagram shows the locations.



### LED Functions

ID	LED	Function	COLOR	STATE
P0	POWER	System Regulated 5 Volts	GREEN	ON NORMAL
P1	P0	Pulse 0 Input	GREEN	FLASH WITH PULSE
P2	P1	Pulse 1 Input	GREEN	FLASH WITH PULSE
P3	P2	Pulse 2 Input	GREEN	FLASH WITH PULSE
P4	ALARM	Active Alarm condition	GREEN	ON ALARM
P5	T0	Pulse 0 Divider Out	GREEN	FLASH WITH PULSE
P6	T1	Pulse 1 Divider Out	GREEN	FLASH WITH PULSE
P7	T2	Pulse 2 Divider Out	GREEN	FLASH WITH PULSE



# SeaGauge-Remote G2 User's Manual

## Board Jumpers

Several special mode options can be configured via on-board jumpers. Normal operation will not require any modification of the jumpers.

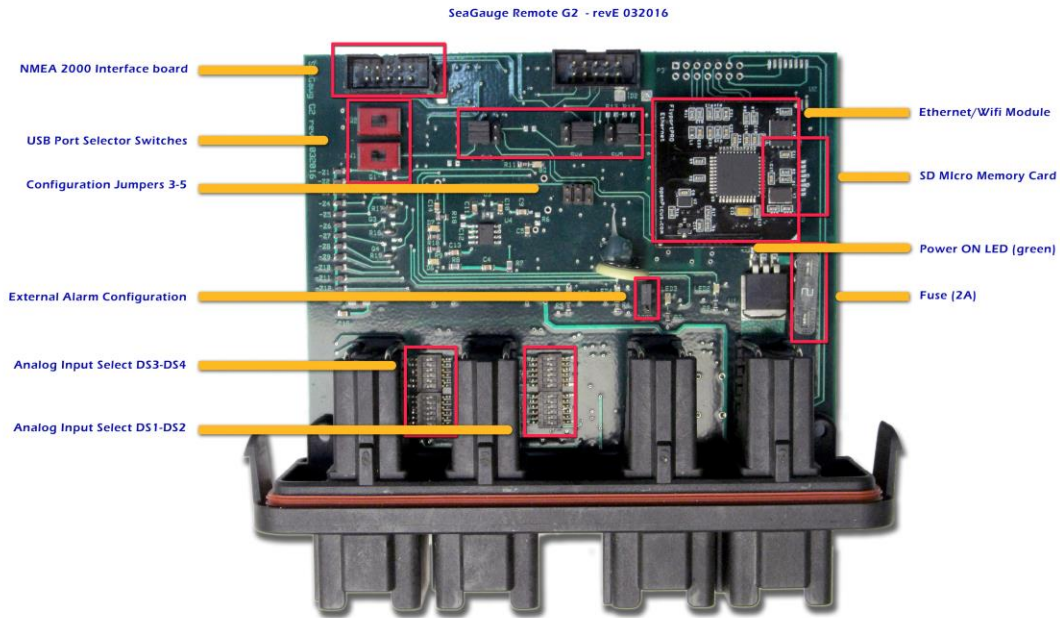

## SeaGauge-Remote G2 User's Manual

The Alarm jumper block (J1) is used to configure the output drive for alarms. Normal operation (3 & 2) is active high drive of Pizo buzzer or LED. If it is desired to drive a relay or high current lamp, configure jumper for 1 & 2 for active low alarm drive of 100 mA.

<i>J1 ALARM</i>				
<i>ID</i>	<i>Pin</i>	<i>Function</i>		<i>STATE</i>
<i>J1-1</i>	1	Relay Drive	1&2	Active Low Alarm
<i>J1-2</i>	2	Alarm Out	-	-
<i>J1-3</i>	3	LED Drive	3&2	Active High Alarm

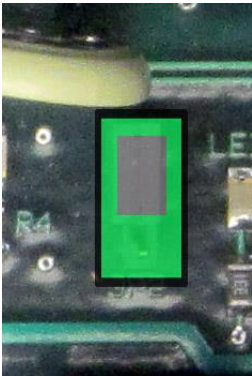

Voltage Drive mode. 0V when alarm off, 3.3 volts when alarm on – Drive small Pizo buzzer or reed relay. Source 50 mA

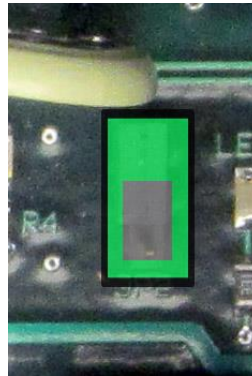

Open Collector Ground drive. Open circuit when alarm off, sink to ground when alarm on. Used to ground relay to drive higher current device. Sinks up to 100 mA

## SeaGauge-Remote G2 User's Manual

The USB jumper block (SW3-SW4) connects the optional USB cable to on-board microprocessor. It is used for factory programming of firmware and should not be altered

<i>J2 USB Controller</i>				
<i>Pin</i>	<i>Function</i>	<i>Pin</i>	<i>Function</i>	<i>STATE</i>
<i>1</i>	uP RX	7	USB TX	1&7 Normal
<i>2</i>	uP XX	8	USB RX	2&8 Normal
<i>3</i>	uP CTS	9	USB RTS	3&9 Normal
<i>4</i>	uP RTS	10	USB CTS	4&10 Normal
<i>5</i>	GND	11	-	
<i>6</i>	5V	12	-	

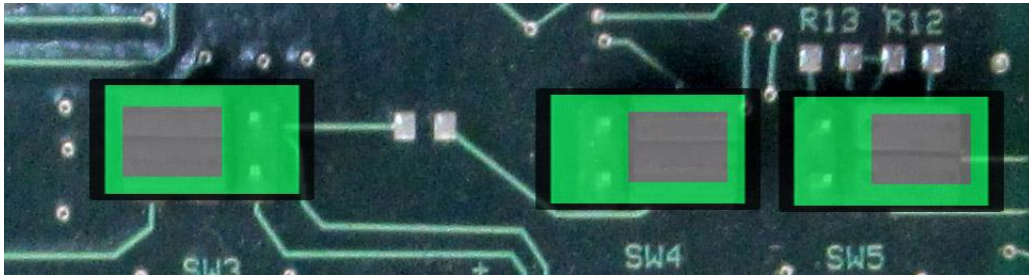

USB Master controller and USB to WiFi module

# SeaGauge-Remote G2 User's Manual

## PORT SWITCHES

SeaGauge-Remote has three miniature switches for configuring the two ports and performing firmware updates.

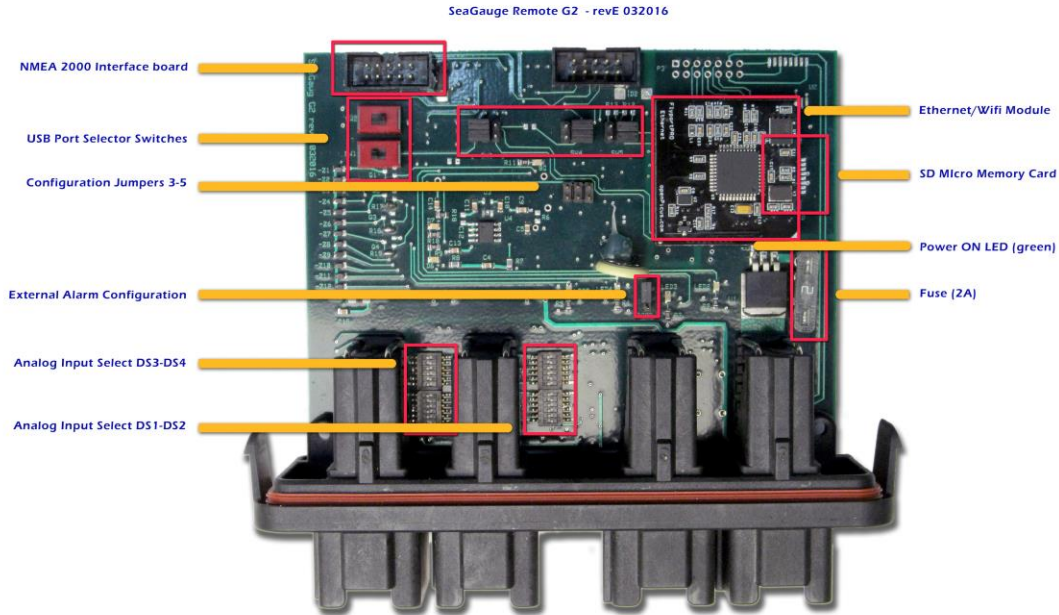

SeaGauge-Remote USB port can be configured to interface to the main SeaGauge processor or optional Ethernet or WiFi module for performing firmware updates. This allows the same USB cable (white) to be used for both modes. The default mode is for connection to vDash for unit configuration and instrumentation display

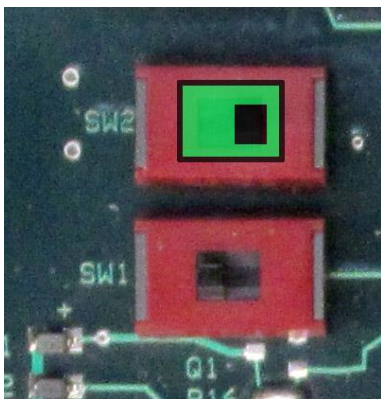

Default position for USB connection to

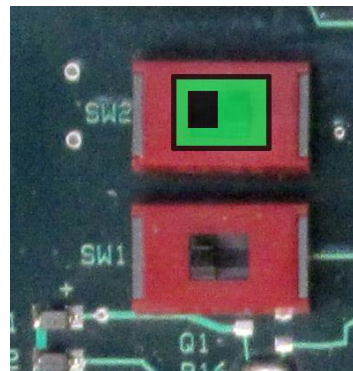

Firmware update of Ethernet or WiFi

# SeaGauge-Remote G2 User's Manual

vDash via PC USB port

module only

## FIRMWARE UPDATE SWITCH

SeaGauge-Remote firmware can be updated by loading new FASH IMAGES using a USB connection to PC via the vDash application. Firmware file uploads can be performed only when SW1 is in FIRMWARE UPDATE mode

<i>Switch</i>	<i>Mode</i>
<i>SW1 = Left</i>	Firmware update via USB
<i>SW1 = Right</i>	Port 0 or 1 in USB mode

When performing a firmware update via USB mode, first power off the unit and move the switch UP (away from the case side and towards the center). Next connect the supplied USB cable (8-pins on one end and TYPE A USB on other). Then re-power the unit and verify the USB drivers are loaded and a virtual COM port is assigned to the unit. Once confirmed, proceed to use vDash to connect and load firmware file.

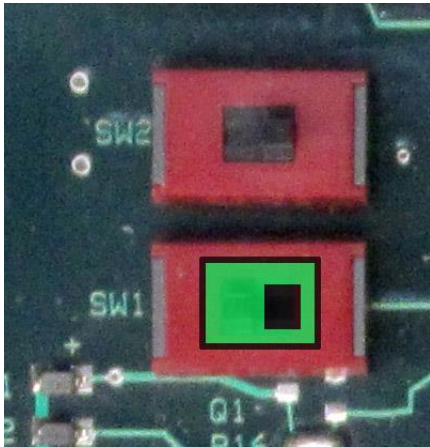

Default position for calibration programming using vDash

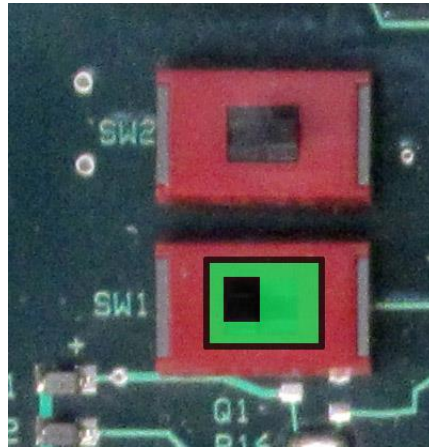

SeaGauge Firmware update position only

Once completed remove power and return SW1 to normal USB mode RIGHT (towards the the center).

## Installation

---

### Mount

SeaGauge-Remote can be mounted by securing the four mounting holes with sheet metal screws in a suitable location. When choosing a location, be sure to include room for sensor and power cable entry as well as USB and serial cables. .

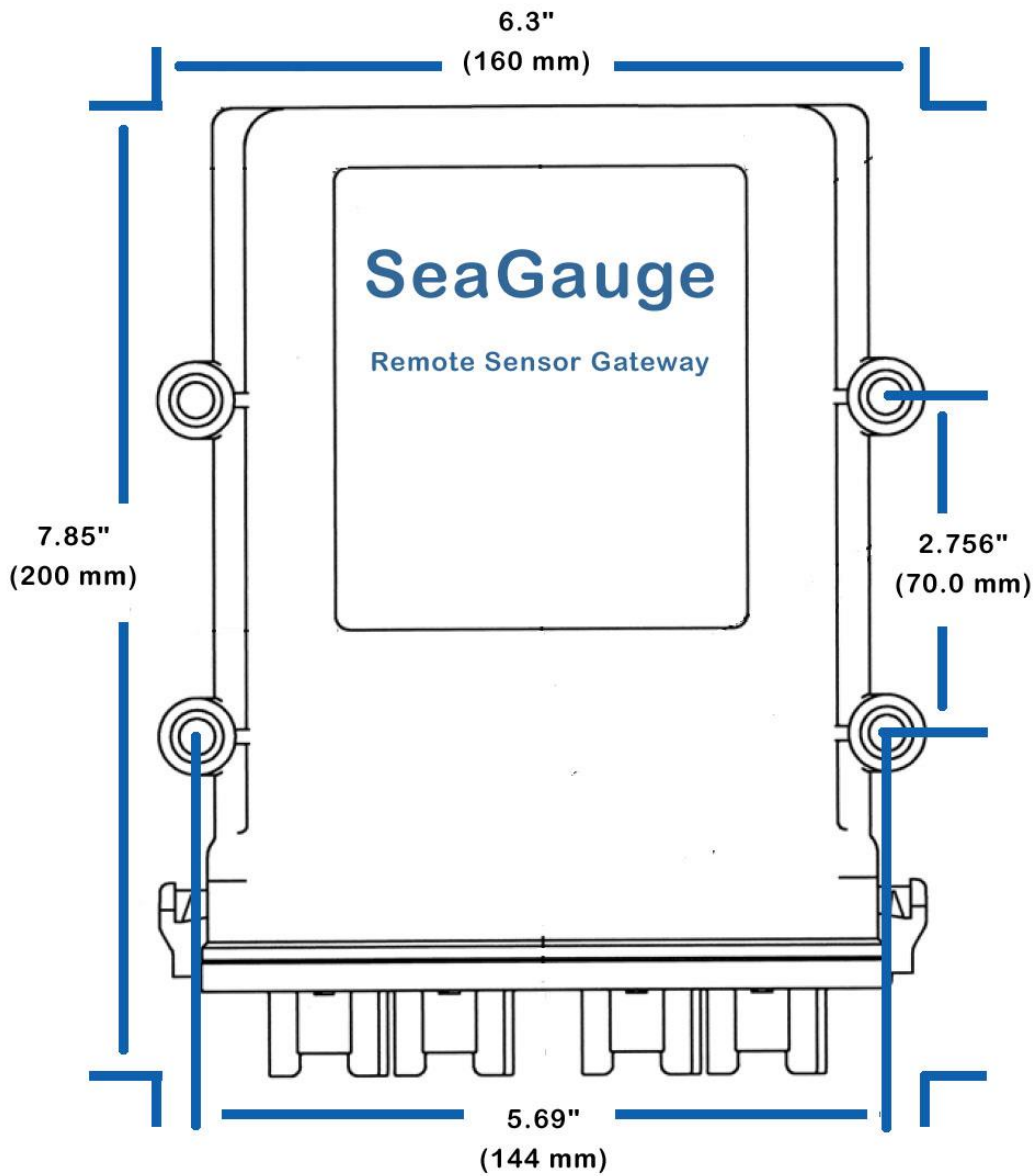

## **SeaGauge-Remote G2 User's Manual**

It is recommended to secure all sensor and power cables to chassis to avoid wires from moving around and breaking loose. USB and Serial cable should also be secured..

### ***Power***

Power is supplied from the accessory bus via a 2 amp fuse. Never attempt to connect power without providing a fused input or serious damage may result. Unit should have power applied when key is in the accessory or run position and power removed when key is off.

Be sure to attach ground lead to a solid ground bus for proper operation. All sensor/sender grounds should be attached to the same ground buss.

### ***Alarm***

The alarm signal can be attached directly to a 3-12 volt pizo buzzer. The ground lead of the pizo buzzer should be attached to the ground buss. Be sure the set the SeaGauge-Remote alarm function be active HIGH when driving a pizo buzzer directly.

An alternate configuration is required for applications where alarms require more then 25 mA or more then 3.3 volts to operate. In this case the unit can be set to active LOW and provide the ground to a relay circuit to drive a high power alarm. The relay should not require more then 25 mA to close but can be hooked to a 12 volt source. When an alarm occurs the unit will ground the relay which is used to drive the alarm

### ***Pulse input***

The unit can detect and count voltage pulses. This is typically used for RPM or MPH calculations. Signals feed into the pulse input should be 5 – 12 volts referenced to ground and not exceed 14 volts. This input is normally attached to the tachometer signal and can be run in parallel with existing gauges. Be careful that the supplied signal does not contain large voltage transients or permanent damage may result. Use caution when connecting directly to the negative terminal of the ignition coil as large voltage spikes may occur if not properly filtered.

### ***Reference Voltage***

The reference voltage output can be used with senders which require a 3.3 volt or 5 volt source such as many pressure senders. This is a low current output not to exceed 500 mA and must be fused to avoid damage to the unit. A built-in 1 Amp fuse is provided to protect the circuit

# SeaGauge-Remote G2 User's Manual

## Signals

The unit supports up to 15 sensor inputs (12 analog and 3 pulse). Refer to the connector diagrams for the proper connection for each type of sender. Any unused sensors should be connected to ground to avoid unwanted noise. Never connect any resistive sensor input (temperature/pressure) directly to a voltage source or damage to the unit may result.

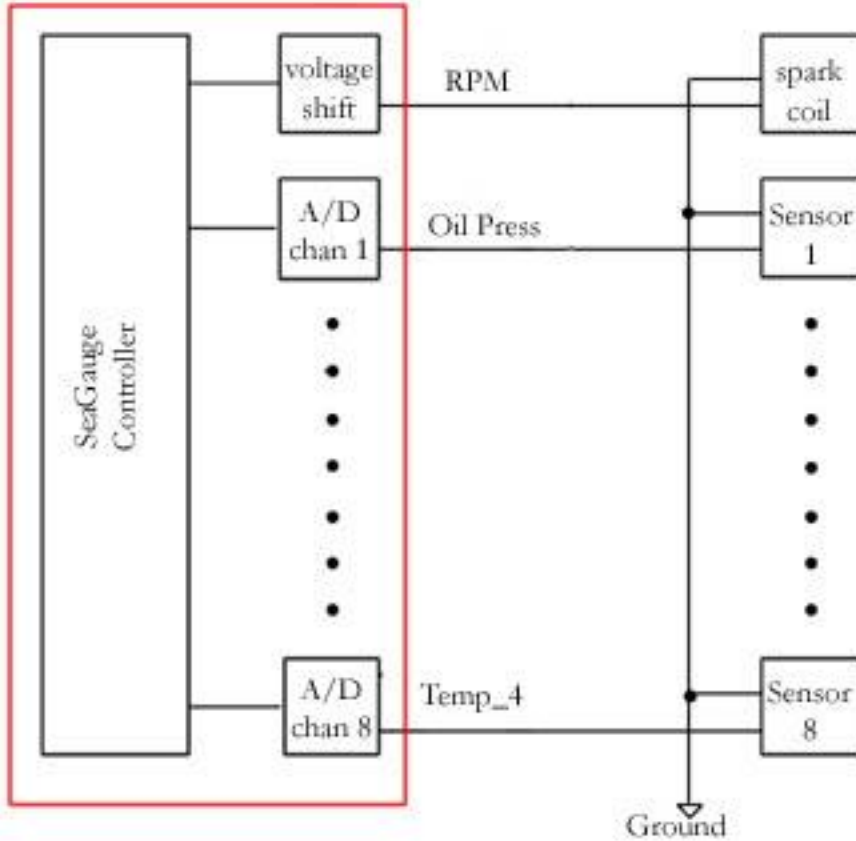



# Calibration Tables

---

SeaGauge-Remote utilizes twelve modifiable calibration tables to convert sensor data into user readable display information. The internal Analog-to-Digital converter converts sensor voltages to 10-bit values. The converter can resolve voltages to  $2.5/1024 = 2.5$  mVolts. These values are averaged and then used to lookup 8 character values form a 256 point lookup table. The use of a lookup table allows for accurate readings from non-linear sensors like temperature senders. The lookup table also allows for easy modification of display values to suit individual preferences and senders.

Following is an example of a partial table used to display battery voltage. The actual table has 256 indexed values. The measured voltage has a range from 0 to 2.5 volts. In this example it is desired to measure battery voltage from 0 to 18 volts so the input voltage from the battery is scaled down using a voltage divider ratio of  $2.5/18 = 0.138$ . The scaled down voltage is converted to an averaged digital value and then used as an index lookup in the table. For example an Input voltage of 1.178 volts becomes index value 18 in the table which corresponds to the 8 character display value of 1.1 vdc. Using this method allows the SeaGauge-Remote to display just about any range of values form a large variety of sensors/senders.

<i>Index</i>	<i>Input Voltage</i>	<i>Measured Voltage</i>	<i>Display value</i>
1	0.065	0.012968	0 vdc
2	0.131	0.025936	0.1 vdc
3	0.196	0.038904	0.1 vdc
4	0.262	0.051872	0.2 vdc
5	0.327	0.06484	0.3 vdc
6	0.393	0.077808	0.3 vdc
7	0.458	0.090776	0.4 vdc
8	0.523	0.103744	0.5 vdc
9	0.589	0.116712	0.5 vdc
10	0.654	0.12968	0.6 vdc
11	0.720	0.142649	0.7 vdc
12	0.785	0.155617	0.7 vdc
13	0.851	0.168585	0.8 vdc
14	0.916	0.181553	0.9 vdc
15	0.981	0.194521	0.9 vdc
16	1.047	0.207489	1.0 vdc
17	1.112	0.220457	1.1 vdc
18	1.178	0.233425	1.1 vdc
19	1.243	0.246393	1.2 vdc
20	1.309	0.259361	1.3 vdc
21	1.374	0.272329	1.3 vdc
22	1.439	0.285297	1.4 vdc
23	1.505	0.298265	1.5 vdc
24	1.570	0.311233	1.5 vdc
25	1.636	0.324201	1.6 vdc

## SeaGauge-Remote G2 User's Manual

<b>26</b>	1.701	0.337169	1.7 vdc
<b>27</b>	1.767	0.350137	1.7 vdc
<b>28</b>	1.832	0.363105	1.8 vdc
<b>29</b>	1.897	0.376073	1.8 vdc
<b>30</b>	1.963	0.389041	1.9 vdc

Each table has 2048 characters to modify and there are 88 choices for each character for a total of over 18,000 character choices for each table. For this reason the tables are much too large to be modified directly from the Setup Mode. However table files can be obtained and downloaded to the unit to allow for modification of any table. All that is needed is a computer interface (RS232 or Bluetooth) and a communication program such as HyperTerminal or the vDash utility. Contact Checto Digital Instruments for more information on obtaining additional table files to match particular senders/sensors.

# Serial Port Protocols

---

The serial port interface of the SeaGauge-Remote unit can be used for real-time status and reprogramming. The status information is sent in either NMEA 0183 format using the \$IIXDR sentence format or NMEA 2000 PGNs. Custom NMEA control sentences are used to control the unit via the serial port interface.

To access the serial port information – connect the supplied cable to computer RS232 port. Set the baud rate of the computer interface to match the baud rate of the unit (57600). Use the standard 8 bits, no parity, and 1 stop bit (8-N-1). Start a serial interface program such as HyperTerminal with these settings then power up the unit. If the connection is correct you will status message from the unit –

SeaGauge-Remote Version 1.02. This indicates the settings are correct.

NMEA 0183 support custom message formats for command and control of propriety equipment. SeaGauge-Remote uses the sentence structures:

\$PCDIC,X - for control where X is the control command

- **N** = Next menu. Same as pressing the top button
- **S** = Set function. Same as pressing the bottom button
- **G** = Start dumping NMEA \$IIXDR sentences in real-time at two updates per second
- **P** = Initiate programming the unit
- **B** = Initialize the Bluetooth module.

\$PCDIS,YYYYY – for status where YYYYY is the returned status information

- \$PCDIS,SEAGAUGE-REMOTE,0001.100,,\*79 = Model Name and Firmware revision

Instrumentation data is returned using the standard NMEA \$IIXDR sentence structure:

\$IIXDR,X,DATA,U,LABEL,CHECKSUM

- **X** = sensor type (G,P,C,..)
- **DATA** = 8 character sensor data value returned from the lookup table
- **U** = unit of measurement specifier
- **LABEL** = 8 character sensor label and a 1 character number representing the channel
- **CHECKSUM** = NEMA check sum calculation on the string

## **SeaGauge-Remote G2 User's Manual**

### ***NEXT MENU***

The **\$PCDIC,N** command is used to command the unit to display the next menu or group. It functions exactly the same as pressing the top button on the unit

### ***SET Function***

The **\$PCDIC,S** command is used to enter Set-up mode or increment a setting. It operates the same as pressing the bottom button on the unit.

### ***Real-time data***

The **\$PCDIC,G** command is used to view real-time instrumentation from the serial port. When the unit is first powered up it will start listening to the default serial port (RS232 or Bluetooth) for commands. It will not dump data until it receives the **\$PCDIC,G** command. To view real-time data type this command in HyperTerminal after you see the prompt. Data for each of the sensors will immediately begin to be displayed in NMEA 0183 \$IIXDR sentence format. The unit will dump data for all 8 sensors every 0.5 seconds.

HyperTerminal allows capture of real-time data to a text file. First enable the Capture Text command under the Transfer menu. Select the file name and location to capture to. Next enter the **\$PCDIC,G** command string to start dumping data to the specified file.

### ***Program Mode***

The **\$PCDIC,P** command is used to put the unit into reprogramming mode. Once in this mode a programming file can be sent to the unit to update Lookup Tables, Sensor labels, Display Groups, Label positions, or channel assignments.

**Use caution when using this command as improper use will erase the unit and it will have to be sent back for reprogramming.**

Programming files can be obtained from Chetco Digital Instruments for use in this mode. These are in a special propriety format and can not be constructed or edited in the field. Contact Chetco Digital Instruments for more information on this option.

Download of new table information requires three steps:

- Enter program mode
- Erase existing table
- Load new table

Program mode is entered by using the **\$PCDIC,P** command from HyperTerminal. If this command is successful the unit will display:

## SeaGauge-Remote G2 User's Manual

- **READY->**

At this point the unit will wait to receive the starting and ending pages to erase. Page numbers are 512 bytes and can be calculated by dividing the starting page memory location by 512. The following table will help you determine the table page numbers.

<i>Table</i>	<i>Bytes /line</i>	<i>Address</i>	<i>Start Page</i>	<i>End Page</i>	<i>Erase Command</i>
<b>Sensor Labels</b>	8	6800	34	37	*3438
<b>Groups</b>	1	7000	38	3B	*383C
<b>Label Positions</b>	1	7000	38	3B	*383C
<b>Alarms</b>	1	7800	3C	3F	*3C40
<b>Channels</b>	1	7800	3C	3F	*3C40
<b>Options</b>	1	7800	3C	3F	*3C40
<b>Lookup Table 0</b>	8	0800	04	07	*0408
<b>Lookup Table 1</b>	8	1000	08	07	*080C
<b>Lookup Table 2</b>	8	1800	0C	0B	*0C10
<b>Lookup Table 3</b>	8	2000	10	13	*1014
<b>Lookup Table 4</b>	8	2800	14	17	*1418
<b>Lookup Table 5</b>	8	3000	18	1B	*181C
<b>Lookup Table 6</b>	8	3800	1C	1F	*1C20
<b>Lookup Table 7</b>	8	4000	20	23	*2024
<b>Lookup Table 8</b>	8	4800	24	27	*2428
<b>Lookup Table 9</b>	8	5000	28	2B	*282C
<b>Lookup Table 10</b>	8	5800	2C	2F	*2C30
<b>Lookup Table 11</b>	8	6000	30	33	*3034

To erase the memory you must enter a “\*” symbol followed by the start and end page values with no spaces. For example to erase the Alarms table enter:

- **\*3C40**

To erase Lookup Table 3 enter:

- **\*1014**

Once you have entered the 5 characters the unit will erase the memory and respond with

- **ERASED->**

At this point the unit will wait to receive the data to reprogram the unit. Use the HyperTerminal Send Text File function to transfer the appropriate file to reprogram the memory. As the file is transferring data the unit will display the memory address for each

## SeaGauge-Remote G2 User's Manual

update. The display should increment till it reaches the end of file and then reset if no errors occur.

### Color Display Protocol

SeaGauge-Remote Sensor unit supports remote color displays directly attached to either or both serial ports. The Remote Color Displays use a propriety serial protocol to convey graphic type, screen position, and display values. The protocol issues commands for each display element on the currently active screen. The elements and positions are configured with the vDash software and downloaded to the unit's firmware tables. The SeaGauge-Remote sensor unit contains graphic position information for all supported displays and uses the stored information to construct the screen image.

The protocol is a fixed length ASCII text string

<i>Graphic Type</i>	<i>X,Y Screen Position</i>	<i>Graphic Index Number</i>	<i>Sensor Value</i>	<i>Sensor Label</i>	<i>Carriage return</i>
<i>m002</i>	"080 120"	135	"2345"	"P RPM "	<CR>

Each Remote Color Display interprets the protocol information to construct the desired graphics

**Graphic Type** – starts with lower case “m” followed by three digit index for type of graphic to display. Possible options are Large Dials, Small Dials, Bar Graphs, vertical Bar graphs, Large text boxes, small text boxes, indicator boxes, switches, and more.

**X,Y Screen Position** – fixed three digit X and Y coordinate to place upper Left corner of graphic element. Range is dependent on display resolution and size.

**Graphic Index Number** – three digit number that defines which graphic element stored in the display to render. Value is based on dial lookup (last 2 digit HEX) from calibration tables and provides for animation of gauge needles and bar graphs

**Sensor Value** – four character sensor display value from calibration table. Lookup is based on sensor voltage

**Sensor Label** – eight character display label entered in the vDash software to describe each of the 16 possible sensor inputs.

Each Port on the Remote Sensor unit can be configured for NMEA 0183, NMEA 2000, or propriety Color Display. If a remote color display is attached directly to the port, then this protocol must be selected.

## SeaGauge-Remote G2 User's Manual

### NMEA 2000 PGNs

SeaGauge-Remote supports NMEA 2000 bus interface with an optional adapter attached to Port 1. The adapter converts propriety serial data to standard NMEA 2000 PGNs for transmission over the NMEA 2000 back bone cable.

Sensor data from the 12 analogs input and 3 pulse inputs is passed through user defined 256 point calibration tables and converted to proper NMEA 2000 PGNs which describe the sensor readings.

Utilizing the NMEA 2000 bus allows many different sensor and display units to interoperate and share information in a simple to connect scheme.

Each of the two SeaGauge-Remote Ports can be independently configured to support either NMEA 0183 protocol, NMEA 2000 protocol, or Remote Display protocol. Configuration of the Port protocol and selected PGNs is done via the vDash Software over USB link to host PC/Laptop.

The following NMEA 2000 PGNs are supported by SeaGauge-Remote.

<i>PGN</i>	<i>Description</i>	<i>Transmit</i>	<i>Receive</i>	<i>Instances</i>
<b>127488</b>	Engine Params Rapid	X	X	16
<b>127489</b>	Engine Params Dynamic	X	X	16
<b>127508</b>	Battery Status	X	X	12
<b>127505</b>	Fluid Levels	X	X	12
<b>127501</b>	Binary Switch Status	X	X	16
<b>127502</b>	Binary Switch Control	X	X	16
<b>127493</b>	Transmission Params	X	X	12
<b>130311</b>	Environmental Params		X	4
<b>130323</b>	Meteorological Data		X	4
<b>130306</b>	Wind Data		X	4
<b>127250</b>	Vessel Heading		X	4
<b>127257</b>	Attitude		X	4
<b>127251</b>	Rate of Turn		X	4
<b>130312</b>	Temperature	X	X	12
<b>127245</b>	Rudder angle	X	X	4
<b>127497</b>	Trip Engine	X	X	4
<b>130316</b>	Temperature extended	X	X	16

Any combination of PGNs and instances can be selected to offer a large variety of configurations.

## SeaGauge-Remote G2 User's Manual

For example, Dual Engine support in one unit can be provided by selecting PGNs 127488, 127489, 127508, and 127505 with instance 0 (PORT engine) and 1 (Starboard Engine)

Alternately, a 12 function Tank monitoring system can be created by selecting PGN 127505 and assigning a separate instance (0-11) to each of the 12 sensor inputs.

### PGN 127488 Engine Parameters Rapid

<i>Fields Supported</i>	<i>Range</i>	<i>Resolution</i>	<i>Units</i>	<i>TX</i>	<i>RX</i>
<i>RPM**</i>	0-10000	25	RPM	X	X
<i>BOOST</i>	0-237 psi	0.92 psi	Pascals	X	X
<i>TRIM</i>	0 – 100%	0.4%	Percent	X	X

\* Default Field – must choose default field when configuring PGN

### PGN 127489 Engine Parameters Dynamic

<i>Fields Supported</i>	<i>Range</i>	<i>Resolution</i>	<i>Units</i>	<i>TX</i>	<i>RX</i>
<i>Engine Temperature**</i>	-20F – 278F	1.5F	Kelvin	X	X
<i>OIL Pressure</i>	0 - 237 psi	0.92 psi	Pascals	X	X
<i>Oil Temperature</i>	-18F – 718F	2.9F	Kelvin	X	X
<i>Alternator Volts</i>	0 - 40V	0.16V	Volts	X	X
<i>Engine Hours</i>	1193046 hours	1 sec	Seconds	X	X
<i>Coolant Pressure</i>	0-471 psi	1.8 psi	Pascals	X	X
<i>Fuel Pressure</i>	0 – 74 psi	0.3 psi	Pascals	X	X
<i>Fuel Rate</i>	0 – 1700 GPH	0.1 GPH	L/sec	X	X

\*\* Default Field – must choose default field when configuring PGN

### PGN 127508 Battery Status

<i>Fields Supported</i>	<i>Range</i>	<i>Resolution</i>	<i>Units</i>	<i>TX</i>	<i>RX</i>
<i>Battery Volts **</i>	0 - 40V	0.16V	Volts	X	X
<i>Battery Current</i>	0 – 410 Amps	1.6 Amps	Amps	X	X
<i>Battery Temperature</i>	-20F – 278F	1.5F	Kelvin	X	X

\*\* Default Field – must choose default field when configuring PGN



## SeaGauge-Remote G2 User's Manual

### PGN 127505 Fluid Level

<i>Fields Supported</i>	<i>Range</i>	<i>Resolution</i>	<i>Units</i>	<i>TX</i>	<i>RX</i>
<i>Fluid Level **</i>	0 – 100%	0.4%	Percent	X	X
<i>Fluid Capacity</i>	0 – 6400 Liters	0.1 Liters	Liters	X	X

\*\* Default Field – must choose default field when configuring PGN

### PGN 127493 Transmission Parameters

<i>Fields Supported</i>	<i>Range</i>	<i>Resolution</i>	<i>Units</i>	<i>TX</i>	<i>RX</i>
<i>Tran Pressure**</i>	0 - 475 psi	1.8 psi	Pascals	X	X
<i>TRAN Oil Temperature</i>	-18F – 718F	2.9F	Kelvin	X	X

\*\* Default Field – must choose default field when configuring PGN

### PGN 130312 Temperature

<i>Fields Supported</i>	<i>Range</i>	<i>Resolution</i>	<i>Units</i>	<i>TX</i>	<i>RX</i>
<i>Temperature LOW*</i>	-20F – 278F	1.3 F	Kelvin	X	X
<i>Temperature MID**</i>	0F – 588F	2.3 F	Kelvin	X	X
<i>Temperature High***</i>	-450F – 711F	5 F	Kelvin	X	X

\* Instance Field = 0 – 129

\*\* Instance Field = 130-133

\*\*\* Instance Field = 134-139

### PGN 130316 Temperature Extended

<i>Fields Supported</i>	<i>Range</i>	<i>Resolution</i>	<i>Units</i>	<i>TX</i>	<i>RX</i>
<i>Temperature High</i>	0F – 16777K	0.001K	Kelvin	X	X
<i>Temperature Set</i>	0F – 6553K	0.1K	Kelvin	X	X

## SeaGauge-Remote G2 User's Manual

### PGN 127497 Trip Parameters

<i>Fields Supported</i>	<i>Range</i>	<i>Resolution</i>	<i>Units</i>	<i>TX</i>	<i>RX</i>
<i>Fuel Rate**</i>	0 - 200	0.25	L/hr	X	X
<i>Fuel Used</i>	16000	1	Liters	X	X

\*\* Default Field – must choose default field when configuring PGN

### PGN 127245 Rudder Position

<i>Fields Supported</i>	<i>Range</i>	<i>Resolution</i>	<i>Units</i>	<i>TX</i>	<i>RX</i>
<i>Position**</i>	-90 - + 90	0.7	degrees	X	X

\*\* Default Field – must choose default field when configuring PGN

### PGN 127501 Binary Switch Status

<i>Fields Supported</i>	<i>Range</i>	<i>Resolution</i>	<i>TX</i>	<i>RX</i>
<i>SWITCH STATUS **</i>	0 - 12	ON/OFF/ERR/UNDEF	X	X

\*\* Switch Status can be generated from Analog Sensor Inputs or Indicator Status Port. The Indicator status module can not be used with the vSwitch Module installed. Instead, switch command status is sent back with PGN 127501 using the same instance as the command PGN 127502.

### PGN 127502 Switch Command Control

<i>Fields Supported</i>	<i>Range</i>	<i>Resolution</i>	<i>TX</i>	<i>RX</i>
<i>SWITCH COMMAND**</i>	0 - 12	ON/OFF/ERR/UNDEF		X

\*\* Switch Command requires a vSwitch Module. Switch commands are echoed back using PGN 127501 using the same instance as assigned to PGN127502. This provides feedback to the transmitting device that the command was received and processed.

# One Year Warranty

---

“We”, “our”, or “us” refers to **Chetco Digital Instruments**, the manufacturer of this product. “You” or “your” refers to the first person who purchases this product as a consumer item for personal, family, or household use.

We warrant this product against defects or malfunctions in materials and workmanship, and against failure to conform to this product's written specifications, all for one year (1) from the date of original purchase by you. **WE MAKE NO OTHER EXPRESS WARRANTY OR REPRESENTATION OF ANY KIND WHATSOEVER CONCERNING THIS PRODUCT.** Your remedies under this warranty will be available so long as you can show in a reasonable manner that any defect or malfunction in materials or workmanship, or any nonconformity with the product's written specifications, occurred within one year from the date of your original purchase, which must be substantiated by a dated sales receipt or sales slip. Any such defect, malfunction, or non-conformity which occurs within one year from your original purchase date will either be repaired without charge or be replaced with a new product identical or reasonably equivalent to this product, at our option, within a reasonable time after our receipt of the product. If such defect, malfunction, or non-conformity remains after a reasonable number of attempts to repair by us, you may elect to obtain without charge a replacement of the product or a refund for the product. **THIS REPAIR, REPLACEMENT, OR REFUND (AS JUST DESCRIBED) IS THE EXCLUSIVE REMEDY AVAILABLE TO YOU AGAINST US FOR ANY DEFECT, MALFUNCTION, OR NON-CONFORMITY CONCERNING THE PRODUCT OR FOR ANY LOSS OR DAMAGE RESULTING FROM ANY OTHER CAUSE WHATSOEVER. WE WILL NOT UNDER ANY CIRCUMSTANCES BE LIABLE TO ANYONE FOR ANY SPECIAL, CONSEQUENTIAL, INCIDENTAL, OR OTHER INDIRECT DAMAGE OF ANY KIND.**

Some states do not allow the exclusion or limitation of incidental or consequential damages, so the above limitations or exclusions may not apply to you.

This warranty does NOT apply in the following circumstances: (1) when the product has been serviced or repaired by anyone other than us, (2) when the product has been connected, installed, combined, altered, adjusted, or handled in a manner other than according to the instructions furnished with the product, (3) when any serial number has been effaced, altered, or removed, or (4) when any defect, problem, loss, or damage has resulted from any accident, misuse, negligence, or carelessness, or from any failure to provide reasonable and necessary maintenance in accordance with the instructions of the owner's manual for the product.

We reserve the right to make changes or improvements in our products from time to time without incurring the obligation to install such improvements or changes on equipment or items previously manufactured.

This warranty gives you specific legal rights and you may also have other rights which may vary from state to state.

REMINDER: You must retain the sales slip or sales receipt proving the date of your original purchase in case warranty service is ever required.

**Chetco Digital Instruments, INC.**  
**1340 Winchuck River Road**  
**Harbor, OREGON 97415**  
**541-469-4783**

## SeaGauge-Remote G2 User's Manual

### SEAGAUGE-REMOTE FIRMWARE LICENSE AGREEMENT

THIS IS A LEGAL AGREEMENT BETWEEN THE END-USER WHO FIRST PURCHASES THIS PRODUCT AS A CONSUMER ITEM FOR PERSONAL, FAMILY, OR HOUSEHOLD USE (“YOU”) AND CHETCO DIGITAL INSTRUMENTS, INC., THE MANUFACTURER OF THIS PRODUCT. (“WE”, “OUR”, OR “US”). USING THE PRODUCT ACCOMPANIED BY THIS LICENSE AGREEMENT CONSTITUTES ACCEPTANCE OF THESE TERMS AND CONDITIONS.

1. This License Agreement applies to the microcode and one or more lookup tables that your product may contain. We refer to these singly as a “FIRMWARE”.
2. The FIRMWARE that your product may contain are licensed, not sold. We grant to you the nonexclusive, non-assignable right to use these FIRMWARE for monitoring sensor/sender data, but only as long as you comply with the terms and conditions of this License Agreement. We reserve the right to terminate this license if you violate any aspect of this License Agreement.
3. The FIRMWARE housed in your product are protected by the copyright notices appearing on the product or its screen(s). You may NOT modify, adapt, translate, reverse engineer, decompile, disassemble, rent, lease, or resell any FIRMWARE, and you may NOT create derivative works based upon any FIRMWARE or its contents.. Any unauthorized reproduction, use, or transfer of a FIRMWARE may be a crime and may subject you to damages and attorney fees.
4. This License Agreement will terminate immediately without prior notice from us if you fail to comply with or violate any of the provisions of this Agreement. Upon termination, you will promptly return all products containing one or more FIRMWARE to us.
5. Prices and programs are subject to change without notice.
6. This License Agreement shall be governed by the laws of the State of Oregon and comprises the complete and exclusive understanding between you and us concerning the above subject matter.

## **SeaGauge-Remote G2 User's Manual**

### **How to Obtain Service**

We back your investment in quality products with quick, expert service and genuine replacement parts. If you're in the United States and you have questions, please contact the Factory Customer Service Department using our number listed below. You must send the unit to the factory for warranty service or repair. Please call the factory before sending the unit. You will be asked for your unit's serial number (shown above). Use the following number:

**541-469-4783**

U.S.A.only. Monday through Friday, except holidays.

Your unit is covered by a full one-year warranty. (See inside for complete warranty details.) If your unit fails and the failure is not covered by the original warranty, Chetco Digital Instruments has a flat-rate repair policy that covers your unit and accessories packed with the unit at the factory. There is a 180-day warranty on all non-warranty repairs from the factory, which is similar to the original warranty, but is for 180 days rather than one year. For further details, please call us at the above number.

Remember, non-warranty repairs are subject to Chetco Digital Instruments published flat rate charges and 180-day warranty.

CHETCO DIGITAL INSTRUMENTS, INC

Box 5359

Brookings, OR 97415

541-469-4783

<http://www.chetcodigital.com>