



Read and follow these instructions carefully before proceeding with installation. Do not deviate from wiring instructions. Incorrect wiring could cause an electrical short with possible fire. Make sure that wiring is dressed away from moving or hot engine components. If wires run through drilled holes, protect the wires using grommets and/or de-burring the holes. Always disconnect battery before making electrical connections. Before re-connecting battery be sure all connections are properly made.

This instrument is designed to operate on 12V DC system.

Various standard making organizations have established guide lines for wiring colors. Those applicable to your installation should be followed.



Make sure to disconnect the battery prior to making any electrical changes.

Included

DAC unit, mating Krimptite plugs, and instructions are provided to facilitate installation of the DAC unit.

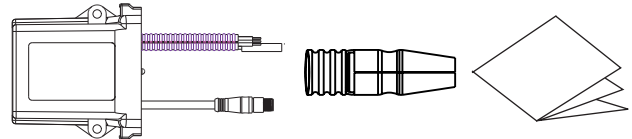

Wiring

The wires coming out of the DAC connect to the sender terminal of the appropriate gauge. Please refer to gauge manufacturers instructions for the remaining connections on the gauge, example: power, ground, and gauge light.

Use the appropriate trim lead for your system, connecting same to your gauge. The other two trim wires coming out of the DAC are not connected and can be tied off.

The volt meter is shown as a reference, no voltage signal is provided from the DAC.

Not all engines provide all gauge signals, refer to engine manuals for gauges supported.

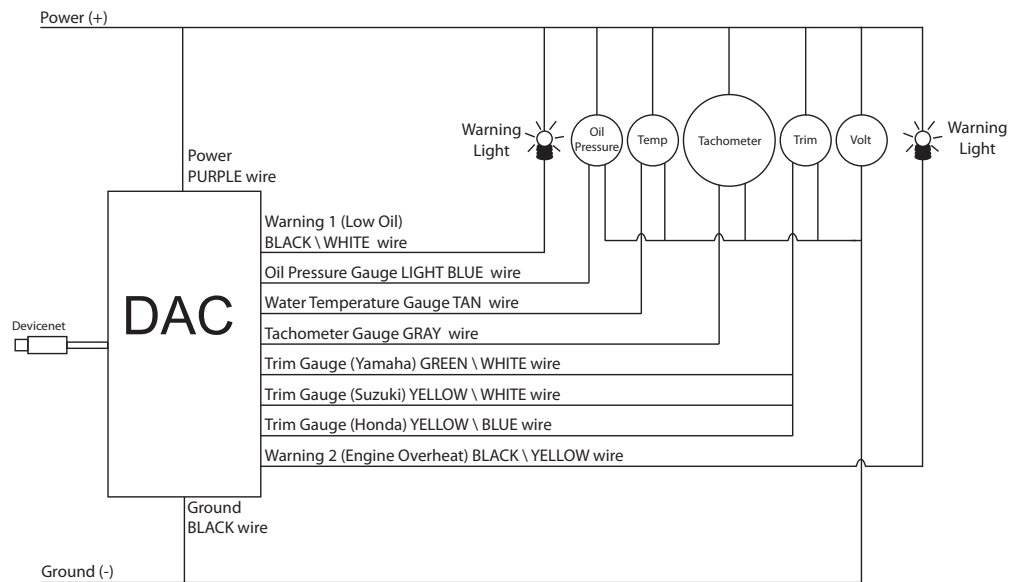

Operation

Under normal operation the green LED will be ON constantly.

The LED will flash when data is not being received by the DAC. If the LED continues to flash after an extended amount of time there could be a problem with the NMEA 2000 Data Bus.

If the LED is not lit, check that the DAC is receiving power.

Troubleshooting

To properly troubleshoot CAN Bus, proper equipment must be used to ascertain if the engine is sending the information. Please refer to a dealer that has trained personnel for this type of engine.

USA Sales/Support
Veethree Electronics and Marine
2050 47th Terrace East
Bradenton, FL 34203 USA
Tel 941-538-7775
Fax 941-775-1222
techservice@veethree.com
www.v3electronicsusa.com